

UN DECADE
OF THE OCEAN:
MATE Inspires
ESG

20

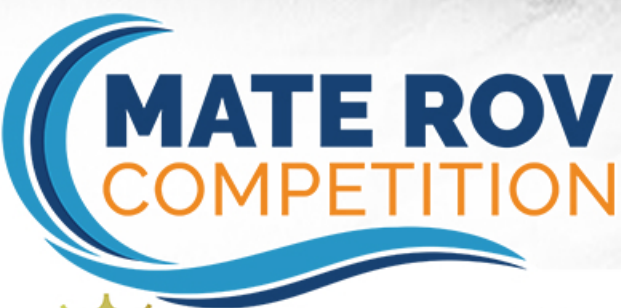

EXPLORER

Release: 21 JAN 2022



SCHMIDT
OCEAN
INSTITUTE



OCEAN INFINITY®

REACH THE WORLD
Bringing the World into Classrooms



2022 MATE ROV COMPETITION:

UN Decade of the Ocean: MATE Inspires ESG

EXPLORER CLASS COMPETITION MANUAL

For general competition information, including a description of the different competition classes and eligibility requirements, visit [Start Competing](#).

Note that this manual is intended for teams attending an in-person competition. A telepresence-specific manual will be posted at a later date.

CONTENTS

- OVERVIEW..... 2
- THINK OF YOURSELVES AS ENTREPRENEURS INSPIRED BY ESG 2
- EXPLORER CLASS DEMONSTRATION 3

- PART 1: PRODUCT DEMONSTRATION..... 6
- OVERVIEW 6
- SCORING OVERVIEW 7
- TIME 8
- CONTEXT & NEED..... 9
- REQUEST FOR PROPOSALS (RFP)..... 10
- WEIGHT RESTRICTIONS 20

- PRODUCT DEMONSTRATION 21
- TASK 1: Marine Renewable Energy 21
- TASK 2: Offshore Aquaculture and Blue Carbon 26
- TASK 3: Antarctica Then and Now – Endurance22 and *MATE Floats!* 31
- PRODUCT DEMONSTRATION RESOURCES 38
- PRODUCT DEMONSTRATION RESPONSIBILITIES 38

- PART 2: PRODUCT DEMONSTRATION PROP BUILDING INSTRUCTIONS & PHOTOS 38

- PART 3: VEHICLE DESIGN & BUILDING SPECIFICATIONS 38
- 1.0 GENERAL 38
- 2.0 SAFETY 39
- 2.1 Job Site Safety Analysis..... 39
- 2.2 Safety Pre-Inspection..... 41
- 2.3 Onsite Safety Inspection 44
- 2.4 Safety inspection protocol 45
- 2.5 Safety Inspection Points 46
- 3.0 SPECIFICATIONS..... 46
- 3.1 Operational..... 46
- 3.2 Mechanical/Physical 47

- 2022 EXPLORER CLASS 1

3.3 Electrical	48
3.4 Onboard Electrical Power.....	54
3.5 Power Shutdown	54
3.6 Fluid Power	55
3.7 Control Systems	58
3.8 Command, Control, & Communications (C3).....	59
3.9 MATE Provided Equipment	60
3.10 Laser Safety Rules	61
PART 4: COMPETITION RULES	62
4.1 GENERAL.....	62
4.2 PROCEDURAL	64
4.3 DESIGN & SAFETY CONSIDERATIONS.....	67
PART 5: ENGINEERING & COMMUNICATION	68
5.1 COMPANY SPEC SHEET	69
5.2 TECHNICAL DOCUMENTATION	69
5.3 ENGINEERING PRESENTATION	70
5.4 MARKETING DISPLAY	72
5.5 CORPORATE RESPONSIBILITY	73
5.6 VIRTUAL REALITY	74
TIPS FOR EFFECTIVE WRITTEN AND ORAL COMMUNICATION.....	75
PART 6: SUBMISSION GUIDELINES AND KEY DEADLINES.....	76
6.1 Documentation	76
6.2 KEY DEADLINES	79



This work is licensed under a [Creative Commons Attribution-NonCommercial-NoDerivatives 4.0 International License](https://creativecommons.org/licenses/by-nc-nd/4.0/). Under this license you may download this document. Please give credit to MATE II. You may not use these materials for commercial purposes without written permission from MATE II. Please click on the Creative Commons link above for license details.

www.materovcompetition.org

www.mateii.org

January 17th edit: Section **3.3.1 Non-ROV Device Power Specifications**. The update provides limits on the maximum voltage and amperage allowed.

OVERVIEW

THINK OF YOURSELVES AS ENTREPRENEURS INSPIRED BY ESG

From harnessing the energy in light, wind, and waves to farming fish, shellfish, and blue carbon and deploying technology to monitor ocean health, individuals who possess entrepreneurial skills are in high

demand and stand out in the crowd of potential job candidates. What are entrepreneurial skills? They include the ability to understand the breadth of business operations (e.g., finances, research and development, media outreach), work as an integral part of a team, think critically, and apply technical knowledge and skills in new and innovative ways. They also include the awareness to take environmental, social, and governance (ESG) factors into consideration when making business decisions. Individuals who develop a mindset for innovation, collaboration, and ESG will be well prepared for the global workplace and ready to tackle today – and tomorrow’s – societal and environmental challenges.

To help you to better understand and develop these skills, the MATE ROV competition challenges you to think of yourself as an entrepreneur. Your first task is to create a company or organization that specializes in solutions to real-world marine technology problems. Use the following questions as a guide.

- What is your company name?
- Who are its leaders – the CEO (chief executive officer – the leader) and CFO (chief financial officer who oversees the budget and spending)?
- Who manages Government and Regulatory Affairs (i.e. who’s in charge of reviewing the competition rules and making sure that they are understood and followed by everyone)?
- Who is responsible for research and development (R&D)?
- Who is responsible for system(s) engineering? Design integration? Testing? Operations? Who is responsible for fund-raising, marketing, and media outreach?
- Who is the company’s ESG research and engagement analyst?
- What other positions might you need? (Depending on your personnel resources, more than one person may fill more than one role.)
- What products and services do you provide?
- Who are your potential clients?

This year, in addition to inspiring ESG, the MATE ROV Competition is embracing the opportunity to highlight the [United Nations Decade of Ocean Science for Sustainable Development](#) and aligning its mission tasks with one or more the [17 UN Sustainable Development Goals](#). Our ocean planet and global community are your “clients” who recently released a request for proposals. A request for proposals (RFP) is a document that an organization posts to solicit bids from potential companies for a product or service. The specifics of your product design and rules of operation as well as the specifics of your product demonstration are included below.

EXPLORER CLASS DEMONSTRATION

All EXPLORER class companies are required to submit a video that:

- Demonstrates the ability of their vehicle to perform specific tasks;
- Shows compliance with MATE’s design, build, and safety specifications.

Video specifications:

Video specifications: The video MUST show the following ROV features for the specified amount of time. Companies can choose to narrate the video to help explain how their vehicle meets these required specifications. Alternatively, a MATE official may schedule a Skype, Google Hangout, GoToMeeting, Zoom, Webex or other type of video conferencing session with the company. During the session, companies must visually show, and answer questions about, the following ROV features.

The video MUST show in this order:

1. 15 seconds (or more) of the 48-volt power supply **(ELEC-002E)**.
2. 15 seconds (or more) showing a properly sized Littelfuse. The company MUST use a ruler to show that this fuse is within 30 cm of Anderson Powerpole connectors. **(ELEC-008E, ELEC-010E)**.
3. 30 seconds (or more) of the inside of the control box showing the wiring and components.
MATE will be looking for:
 - No exposed wiring **(ELEC-017E)**.
 - That the control box is neatly laid out with attention to workmanship. **(ELEC-022E)**.
 - Separation and identification of 120VAC wiring from DC and control voltages. **(ELEC-023E)**. If 120VAC is not used in the control box, you should video a slide stating that AC power is not used in the control box.
4. 15 seconds (or more) in the control system showing that there is no conversion of the 48V until it reaches the ROV. Power supplies, ESCs, H-Bridges or other voltage conversion devices are not allowed on the surface. **(ELEC-003E & ELEC 004E)**
5. 30 seconds (or more) showing any hydraulic / pneumatic systems including a pressure release valve and regulator in the system **(FLUID-007, FLUID-011)**, and that any pressurized cylinder, pressure storage device meets the MATE specifications of **(FLUID-012, FLUID-013)**. In addition, the type of fluid should be clearly stated in the video **(FLUID-002, FLUID-003, FLUID-004)** If the vehicle does not use fluid power, **you should video a slide stating that Fluid Power is not used on this ROV for 10 seconds.**
6. 15 seconds (or more) showing the tether and wires, with strain relief, entering the control station **(ELEC-024E)**
7. 15 seconds (or more) showing the tether entering the ROV and strain relief for the tether **(ELEC-024E)**
8. 60 seconds (or more) total, 10 seconds (or more) per side of the ROV (4 sides plus top and bottom) showing that all motors are waterproofed and propellers are shrouded and protected with guards. There are no sharp edges or elements of the ROV that could cause damage **(MECH-006, ELEC-017E)**.

Video demonstrating specific tasks: Following those requirements, the video must demonstrate that the ROV can complete the following product demonstration tasks. The ROV must complete all the tasks within 15 minutes.

The UNCUT video must show the vehicle:

1. Launching safely from the side of the pool and maneuvering to tasks.
 - a. See specifications (**MECH-004 & MECH-005**).
2. Completing the required tasks. This includes:
 - a. **Task 1:** Marine Renewable Energy
 - i. Removing a ghost net from inter-array cable
 1. Pulling a pin to simulate cutting the ghost net free
 2. Removing the ghost net from the water

Note: The pin on the ghost net must be positioned midwater, at least 50 cm above the bottom of the pool.
 - b. **Task 2:** Offshore Aquaculture and Blue Carbon
 - i. Maintaining a healthy environment
 1. Collect a mort
 2. Inserting a mort into the collection tube
 - ii. Farm seagrass
 1. Prune an existing seagrass bed
 2. Plant a new seagrass bed

The camera angle must demonstrate that the ROV is under its own power and not assisted by humans when in the water. The MATE ROV Competition requires that the camera show the complete ROV in the field of view at all times. A video that cuts between camera angles will not pass the demonstration requirement of “uncut” footage. The video is permitted to show a split screen or may incorporate a separate window showing the ROV camera or other footage. However, the video **MUST** show an uncut view of the vehicle from launch to completion of the tasks. The tasks must be completed within 15 minutes.

Companies may complete the tasks in any order they wish.

* Companies that advance from an EXPLORER class regional with 5 teams or more are not required to submit a video showing completion of the required tasks. **However, these companies must still submit the required specifications video.**

See [Documentation Submissions | MATE ROV Competition Website](#) for submission information. Additional submission information can be found in **PART 6: SUBMISSION GUIDELINES AND KEY DEADLINES**.

Companies are allowed to make minor changes to their ROV after their video demonstration, but the overall systems should be the same. Minor changes include adding/removing buoyancy, adding tools/sensors that were not used for the demonstration, etc. The frame, motor configuration, and the control system must be the same for the video demonstration and the World Championship competition. Safety inspectors will refer to images of the ROV and control system taken from the demonstration video. Vehicles with different systems will not pass the safety inspection.

NOTE for 2022!!!

Due to the continued impact of the pandemic, EXPLORER class teams may or may NOT be encouraged to attend RANGER/NAVIGATOR/SCOUT regional events this competition season to showcase their vehicle. [Contact your regional coordinator](#) to determine whether or not you will be encouraged to attend the regional event.

Regional competitions benefit from the participation of EXPLORER class companies by:

- Showcasing EXPLORER ROVs to RANGER, NAVIGATOR and SCOUT class companies to help them to learn about advanced systems and get ideas for “next year”
- Inspiring RANGER, NAVIGATOR, and SCOUT students to see what’s possible if they continue to progress through the competition classes
- Providing examples of educational pathways and potential post-secondary institutions and programs to continue to pursue STEM learning
- Having access to additional volunteers and judges

Companies benefit from attending the regional by:

- Having access to the product demonstration props and the opportunity to conduct a “wet” run
- Receiving feedback from safety inspectors, including identification of potential safety violations and what can be done to enhance their vehicle from a safety standpoint
- Receiving technical help from engineers and technicians as well as from other companies
- Gaining insight and sharing ideas with other companies
- Earning points for the corporate responsibility portion of the competition

NOTE for 2022!!!

MATE strongly encourages companies to demonstrate at, compete at, or assist with a regional event. Companies that attend a regional event tend to have an advantage at the MATE World Championship. For example, eight of the top ten EXPLORER class finishers in both 2018 and 2019 attended a RANGER regional or competed at an EXPLORER regional. In 2017, all five the top EXPLORER class finishers attended a RANGER regional or competed at an EXPLORER regional.

PART 1: PRODUCT DEMONSTRATION

OVERVIEW

EXPLORER class companies will take part in ONE product demonstration that consists of three distinct tasks:

TASK #1: MARINE RENEWABLE ENERGY

TASK #2: OFFSHORE AQUACULTURE AND BLUE CARBON

TASK #3: ANTARCTICA THEN AND NOW: ENDURANCE22 AND MATE FLOATS!

NOTE: For EXPLORER class companies participating in regionals, your regional competitions may not include all 3 tasks of the product demonstration; regional competitions may also give companies more than one attempt at the product demonstration. Contact [your regional coordinator or visit your regional contest's website](#) to determine what will take place at your regional competition. Regardless, the product demonstration score will be added to your [ENGINEERING & COMMUNICATION](#) and [SAFETY](#) scores to determine your total, overall score for the competition.

SCORING OVERVIEW

The competition consists of product demonstrations, engineering and communication, and safety with the following scoring breakdown:

- **Product demonstrations**
 - 300 points (max), plus a time bonus
 - Weight restrictions
 - 10 points (max)
 - Product demonstration organizational effectiveness
 - 10 points (max)
- **Engineering & Communication**
 - Technical documentation
 - 100 points (max)
 - Engineering presentations
 - 100 points (max)
 - Marketing displays
 - 50 points (max)
 - Company Spec Sheet
 - 20 points (max)
 - Corporate Responsibility
 - 20 points (max)
 - Virtual Reality assets
 - 25 points (max)
- **Safety**
 - Initial Safety and Documentation Review
 - 20 points (max)
 - Safety Inspection
 - 30 points (max)
 - Job Safety Analysis (JSAs)
 - 10 points (max)

TOTAL POINTS = 695

NOTE: For EXPLORER class companies attending regional competitions, your regional may not require all of the Engineering & Communications components or offer the opportunity to earn points for Corporate Responsibility. Contact [your regional coordinator or visit your regional contest's website](#) for more information.

TIME

Each product demonstration includes:

- 5 minutes to set up at the product demonstration station
- 15 minutes to attempt the tasks
- 5 minutes to break down and exit the product demonstration station

Your company will have 5 minutes to set up your system, 15 minutes to complete the tasks, and 5 minutes to demobilize your equipment and exit the product demonstration station. During the 5-minute set-up, you may reassemble your vehicle after the weigh-in and place it in the water for testing and/or trimming purposes. The 15-minute demonstration period will begin after the full 5 minutes of set up time expires, regardless of whether the company is ready to start the product demonstration. It may begin sooner if your CEO notifies the product demonstration station judges that your company is ready to begin.

At any time during the demonstration, you may pilot your ROV to the surface and remove the vehicle from the water for such things as buoyancy adjustments, payload changes, and troubleshooting, but the 15-minute product demonstration clock will only stop if a judge determines it is necessary for reasons beyond your control. Otherwise, the clock will only stop after all of the tasks are successfully completed, the ROV has been piloted into the “resident ROV” docking station under its own power. Your ROV is not required to return to the surface between tasks.

Your 5-minute demobilization will begin as soon as the 15-minute demonstration time ends, regardless of where your ROV is located (i.e., still at depth, on the surface, etc.).

Regional competitions may alter the set-up, product demonstration time, or demobilization time. Contact [your regional coordinator or visit your regional contest's website](#) to verify the timing of your product demonstrations.

TIME BONUS

Companies will receive a time bonus for each product demonstration if you:

- 1) successfully complete all the tasks,
- 2) successfully pilot your ROV into the “resident ROV” docking station

Companies will receive 1 point for every minute and 0.01 point for every second under 15 minutes remaining.

CONTEXT & NEED

The global ocean community is invited to plan for the next ten years in ocean science and technology to deliver, together, the ocean we need for the future we want!

– [United Nations Decade of Ocean Science for Sustainable Development](#)

The MATE ROV Competition has accepted this invitation and is challenging its global community of learners to come together to innovate, create, and develop solutions to the problems that impact us all.

The United Nations proclaimed a *Decade of Ocean Science for Sustainable Development (2021-2030)* to support efforts to reverse the cycle of decline in ocean health and to gather the global community behind a common goal: creating improved conditions for sustainable use and development of our world ocean.

The ocean is the largest component of our planet’s ecosystem; it stabilizes climate and supports life on Earth and human well-being. However, the [First World Ocean Assessment](#) report released in 2016 found that much of the ocean is now seriously degraded, with changes and losses in the structure, function, and benefits from ocean systems.

Understanding how the ocean responds to pressures and taking action to improve management practices is critical for sustainable use and development of this precious resource. Ocean observations and research are critical to predicting the consequences of change, designing ways to mitigate these consequences, and guiding communities to embrace and adapt these practices for the good of us all.

It’s no secret that one of the biggest threats the world ocean faces is the impact of climate change. Marine habitats and wildlife are already suffering the consequences of rising sea temperatures and acidification, as are the coastal communities that depend on them. The impact of multiple pressures on the ocean is projected to increase as the human population grows towards the expected 9 billion by 2050. Without aggressive action to reduce carbon emissions over the next decade, the damage to our oceans and our planet has the potential to be horrific.

Marine renewable energies (MREs), such as offshore wind farms, tidal turbines, wave energy converters, and floating solar panels, play a key role in mitigating the effects of climate change and paving the pathway to a sustainable future. MREs provide a significant contribution to the production of low-carbon renewable energy around the world and are an important ally in the fight against climate change. Another ally is Blue Carbon, which is the carbon stored in coastal and marine ecosystems, such as mangroves and seagrasses, the latter of which can absorb and store carbon 35 times more efficiently than rainforests. Aquaculture, the breeding, rearing, and harvesting of fish, shellfish, algae, and other organisms in all types of water environments, is also an ally in the quest for a sustainable future on our ocean planet. It is the fastest growing food supply sector in the world and is and will continue to be needed to feed an ever-growing human population.

This MATE ROV Competition season the “client” is once again us – our global community – and each task area included within the request for proposals (RFP) aligns with one or more the [17 UN Sustainable Development Goals](#) that, while not specific to the Decade of the Ocean, offer a blueprint to achieve a

better and more sustainable future for all. Each task also embraces [ESG](#) – the environmental, social, and governance factors that more and more companies and organizations are taking into consideration when making business and management decisions.

Joined by partners [Ocean Infinity](#), [Reach The World](#), and the [National Science Foundation-funded GO-BGC Project](#), among others, the MATE ROV Competition is challenging its community to design and build a remotely operated vehicle and the necessary sensors and tooling to support work to combat climate change, provide clean energy, feed our growing global population, monitor ocean health, preserve our maritime history, and “deliver, together, the ocean we need for the future we want!”

REQUEST FOR PROPOSALS (RFP)

1. General

a. *Marine Renewable Energy*

UN Sustainable Development Goals:

#7 Affordable and Clean Energy

#12 Responsible Consumption and Production

Offshore wind farms are one example of marine renewable energy platforms that are playing a key role in combating climate change and placing us on a pathway to a sustainable future. Offshore wind speeds tend to be faster than on land, so small increases in wind speed yield large increases in energy production. Put simply, faster wind speeds offshore mean much more energy can be generated compared to land-based systems. Offshore wind speeds also tend to be steadier than on land; a steadier supply of wind means a more reliable source of energy. For those reasons and more, offshore wind power is poised to become an important contributor to the ocean economy and job creation; in 2016, the [Organisation for Economic Co-operation and Development \(OECD\)](#) predicted that offshore wind power will grow to 8% of ocean economy by 2030 and that its industry will employ 435,000 people.

Types of Offshore Wind Turbines

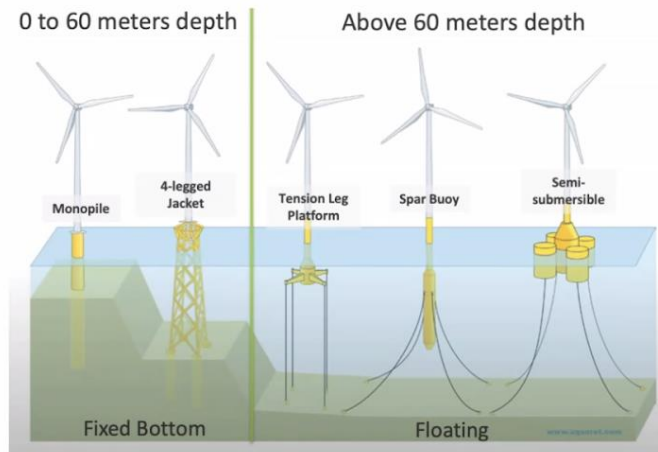

- There are two types of offshore wind turbines: (1) fixed bottom (used for waters of 0-60 m depth) and (2) floating (used in waters greater than 60 m depth).

[Offshore Wind Farms and the Morro Bay Project](#)



[ROVs play a role in the installation and maintenance of offshore wind turbines](#)

[Ocean Infinity](#) supports the installation and maintenance of marine renewable energy systems, including floating and fixed offshore wind turbines. The company is equipping its [Armada fleet](#) of uncrewed robotic surface vessels with the capability to operate other underwater technologies, such as ROVs, from these platforms. While the vessels are controlled remotely, there is room for a “lean” crew to travel with the ROV to conduct inspections and routine maintenance of offshore wind farms and their impact on the surrounding environment. Conducting inspections and maintenance includes repairing damaged cables and buoyancy modules as well as removing nets or other artifacts that become caught on the subsurface structure. As responsible ocean stewards, monitoring the environmental impact includes deploying instrumentation and sensors, such as hydrophones to detect the presence and proximity of marine mammals.



The goal is to eventually provide a resident ROV that “lives” on the farm and is preprogrammed to do inspections, maintenance, and monitoring at given time intervals. Until that capability is developed, operators will continue to pilot ROVs to complete these tasks as well as to test out the ability of the ROV to “park” itself in a docking station.

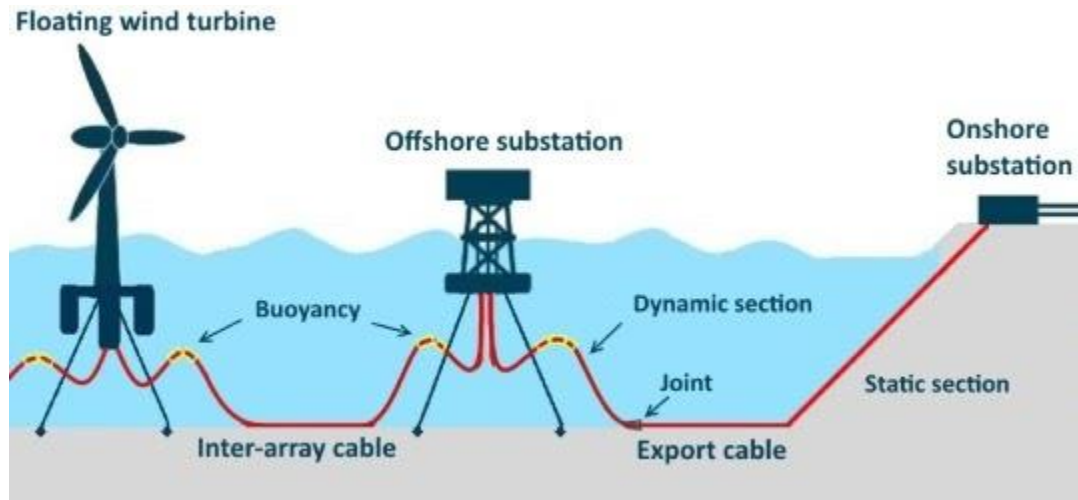

Electrical system of a floating offshore wind farm

b. Offshore Aquaculture and Blue Carbon

UN Sustainable Development Goals:

#2 Zero Hunger

#13 Climate Actions

#14 Life Below Water

Aquaculture is and will continue to contribute substantially to global food supplies, which is critical for “food security” for our ever-growing global population. Aquaculture also supports people and communities by providing business opportunities and decent jobs. Aquaculture production is forecasted to grow to between 102-105 million tons by 2027, according to OECD and Food and Agriculture Organization of the United Nation outlooks. To keep up with demand, more and more aquaculture production is moving offshore. Good water quality, steady ocean currents, and low variance in temperature gives optimal growing conditions, reduces the probability of diseases and parasite infestations, and improves fish health.

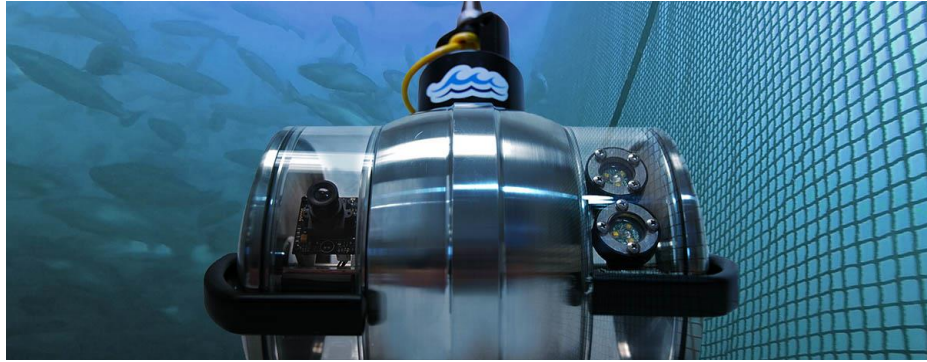

[Aquaculture ROV | Top 3 Uses for the Aquaculture Industry](#)

Aquaculture companies like [Forever Oceans](#) use ROVs like the [BlueROV2](#) to inspect offshore aquaculture pens and maintain a healthy environment for both fish and the surrounding ocean community. Similar to offshore wind farms, the goal is to eventually “park” an ROV within the pen and preprogram it to carry out inspections and maintenance. However, until that time, operators are needed to perform these tasks, which include inspecting the nets for structural integrity, making repairs, and removing fish mortalities (aka “morts”).

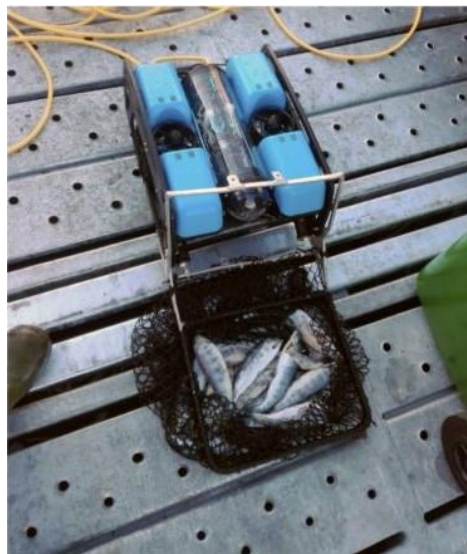

[A BlueROV2 removing “morts”](#)

In addition to marine renewables, Ocean Infinity supports [Blue Carbon](#) initiatives like [Project Seagrass](#). Project Seagrass restores and cultivates seagrass beds, which are extremely effective at absorbing and storing CO₂. Global estimates suggest that an area of seagrass approximately the same size as two soccer fields is lost every hour. Protecting what is left is vital, not only because of seagrasses’ role in carbon sequestration, but also because thousands of species, such as [manatees](#), sea turtles, shellfish, and seahorses, rely on seagrass beds for food and habitat. [Project Seagrass](#) is currently looking for a mechanism that can both “plant” new and prune existing seagrass beds; pruning keeps the grasses healthy and promotes growth.



Seagrasses absorb and store large amounts of carbon – and provide food for endangered species

c. Antarctica Then and Now – Endurance 22 and MATE Floats!

UN Sustainable Development Goal:

#13 Climate Action

Nowhere is the effect of climate change more evident than at the poles; images of diminishing ice sheets, starving polar bears, thin-shelled mollusks illustrate the catastrophic impact that warming temperatures and increased CO₂ are having on these regions. In the Southern Ocean, scientists have discovered that global warming is affecting the Antarctic Circumpolar Current, by far the largest ocean current in the world, in complex ways and that these effects could complicate the ability to fight climate change in the future.

Antarctica is, effectively, melting from the bottom up, as evidenced by holes the size of South Carolina (or larger) that scientists have observed in the sea ice. A slew of environmental factors must come together at the same time for these “super colossal holes” to open up; the ocean under the ice gets mixed up and, ultimately, this mixing transports relatively warmer water up to the surface where it melts a hole in the floating ice. The gaping holes form rapidly, without notice.

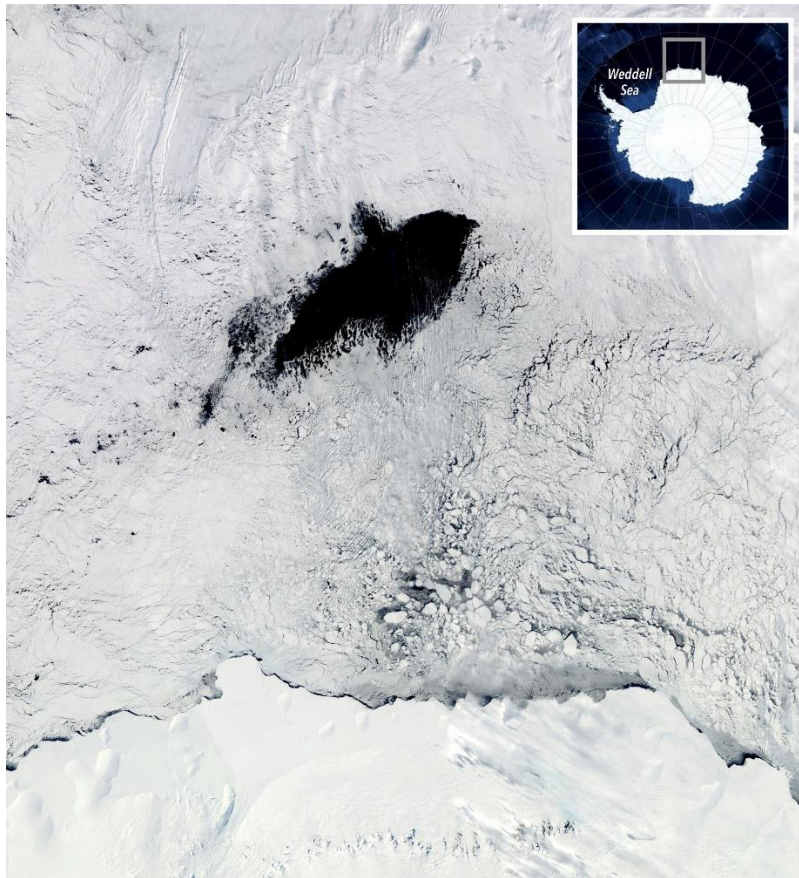

[A polynya as viewed from space](#)



The goal of the [National Science Foundation \(NSF\)-funded GO-BGC Project](#) is to build a global network of chemical and biological sensors that will monitor circulation, chemistry, biology, and overall ocean health. Scientists, engineers, and technicians are using NSF grant funds to build and deploy 500 robotic ocean-monitoring floats around the globe, including in Antarctic waters, where they hope to learn more about changing ocean conditions' impact on the Antarctic Circumpolar Current and the formation of polynyas.



[Launching a float in the Southern Ocean](#)

[Reach The World](#) is part of an expedition to find the *Endurance*, [Sir Ernest Shackleton's](#) ship which was crushed by sea ice and sank in the Weddell Sea in November 1915. Organized and funded by the [Falklands Maritime Heritage Trust](#), [Endurance22](#) is scheduled to set sail in February 2022. While the coordinates where the ship sank were documented, the challenge lies in accessing the wreck. The expedition will use an icebreaker to get close to the location; if they can't reach the site itself, they will set up a camp on the moving pack ice. The plan is drill holes in the ice through which operators will deploy an ROV, flying transects until they find the ship.

 **REACH THE WORLD**
Bringing the World into Classrooms



ENDURANCE22

The hunt for Shackleton's lost ice ship

While the goal of Shackleton's expedition had little to do with monitoring the impacts of climate change, it did pave the way for future expeditions and research to explore and understand the Southern Ocean and its role in ocean circulation, heat exchange, chemistry, and health.

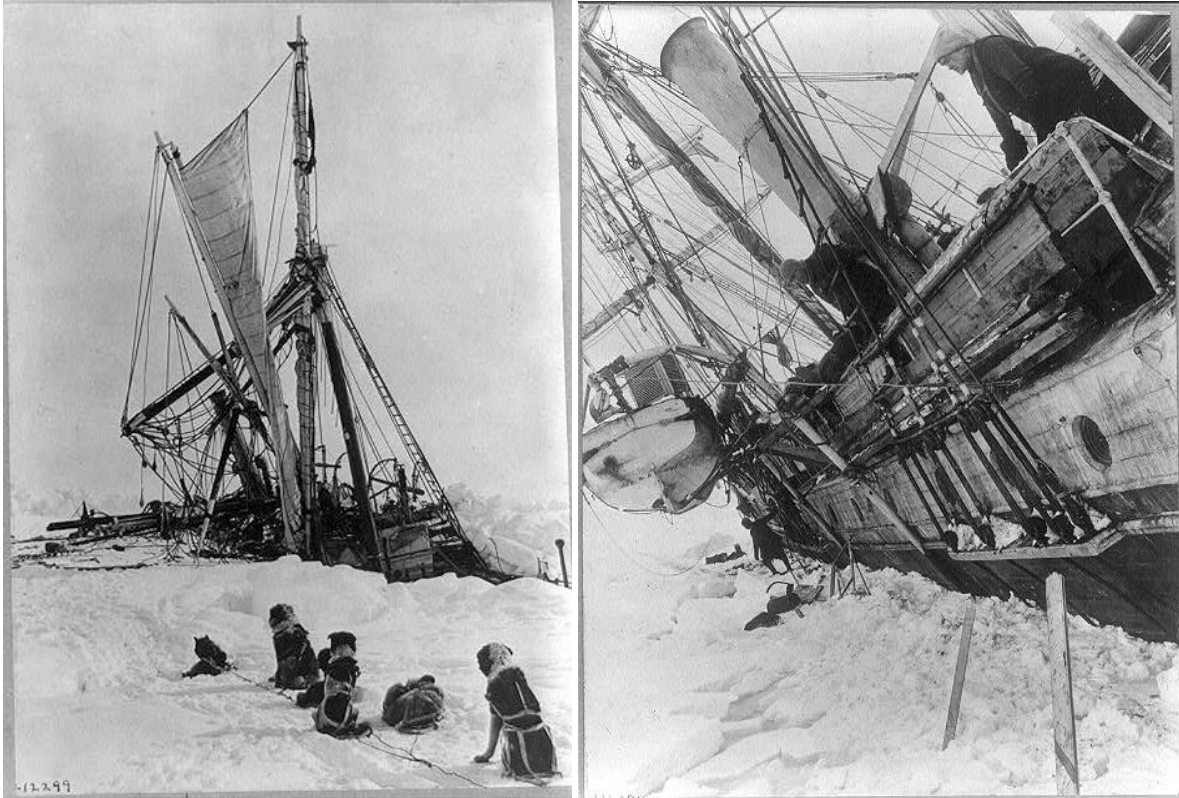

[The Endurance, a few months before it sank in the Weddell Sea on October 27, 1915](#)

THIS IS WHERE YOUR MISSION BEGINS.

d. Mission Scope and Purpose

This and the following sections contain the technical specifications and requirements for ROV services needed to support the *UN Decade of the Ocean: MATE Inspires ESG*. In 2022, ROV services include:

1) TASK 1: Marine Renewable Energy

UN Sustainable Development Goals:

#7 Affordable and Clean Energy

#12 Responsible Consumption and Production

- Replace a damaged section of an inter-array cable
- Replace a damaged buoyancy module on an inter-array cable of a floating offshore wind turbine
- Deploy a hydrophone to detect and record the presence of marine mammals
- Remove a ghost net caught on the wind turbine's substructure
- Pilot into a "resident ROV" docking station

2) TASK 2: Offshore Aquaculture and Blue Carbon

UN Sustainable Development Goals:

#2 Zero Hunger

#13 Climate Action

#14 Life Below Water

- Inspect an offshore aquaculture fish pen
- Repair the damaged area
- Remove marine growth
- Manage mortality by removing morts from the fish pen
- Determine the average size and biomass of the fish cohort
- Farm seagrass

3) TASK 3: Antarctica Then and Now – Endurance 22 and MATE Floats!

UN Sustainable Development Goal:

#13 Climate Action

- Recover a GO-BGC float to conduct diagnostics
- Design and construct an operational vertical profiling float
- Find and map the location of the *Endurance*
- Create a photomosaic of the wreck
- Measure the length of the of the wreck

2. Specifications

See the specific tasks described below as well as the [VEHICLE DESIGN & BUILDING SPECIFICATIONS](#) and [PART 4: COMPETITION RULES](#) sections.

3. Maintenance and Technical Support

The company shall warrant the ROV and associated systems and equipment for at least the duration of the product demonstrations. Repair or replacement shall be at the company's expense, including the cost of shipping the ROV to and from the competition facility.

During regional events, the company shall provide at least one day of technical support to resolve hardware, software, and operational issues. They shall provide at least three days of the same for the World Championship event.

4. Shipping and Storage

Refer to [Shipping Information](#) for specifics on shipping to the MATE World Championship site.

Delivery of the ROV and associated systems and equipment shall be no later than the date of the geographically closest regional contest or by the first day of the MATE World Championship (date coming soon).

5. Evaluation Criteria

- a. Technical documentation
- b. Engineering presentation
- c. Marketing display
- d. Company spec sheet
- e. Product demonstration
- f. Safety

6. References

a. GENERAL

- [United Nations Decade of Ocean Science for Sustainable Development](#)
- [17 UN Sustainable Development Goals](#)
- [A Hotter Future Is Certain, Climate Panel Warns. But How Hot Is Up to Us.](#)
- [ESG \(environmental, social and governance\)](#)
- [Ocean energy: An important ally in the fight against climate change](#)
- [Marine Renewable Energy](#)
- [The Blue Carbon Initiative](#)
- [What is aquaculture?](#)
- [Value and importance of aquaculture](#)

b. TASK 1: Marine Renewable Energy

- [Sea Technology August 2021](#)
- [What are the advantages and disadvantages of offshore wind farms?](#)
- [The Technology of Offshore Wind Power and the Morro Bay Wind Farm](#)
- [A metaheuristic optimization model for the inter-array layout planning of floating offshore wind farms - ScienceDirect](#)
- [The world's first offshore diver less remote hyperbaric tie in operation](#)

c. TASK 2: Offshore Aquaculture and Blue Carbon

- [It's about fish, and so much more: Offshore Aquaculture](#)
- [Aquaculture ROVs in The Fish Farming Industry](#)
- [Aquaculture Cage Net Inspection with Autonomous ROV Navigation](#)
- [Net Patch Tool Demonstration | Aquaculture](#)
- [AI Applied to Aquaculture Aims for Improved Efficiency, Healthier Fish](#)
- [Nonintrusive methods for biomass estimation in aquaculture with emphasis on fish](#)

d. TASK 3: Antarctica Then and Now – Endurance22 and MATE Floats!

- [Rising From the Antarctic, a Climate Alarm](#)
- [Super colossal holes in Antarctic ice demystified by scientists](#)
- [GO-BGC | Global Ocean Biogeochemistry Array](#)

- [2021 MATE Floats! | MATE ROV Competition Website](#)
- [Endurance22](#)

IMPORTANT NOTE: Questions about production demonstrations and design and building specifications must be posted to the competition FAQs board located at <http://forums.marinetech2.org/index.php>. This allows all companies to see the questions and answers and helps to avoid duplicate questions. That said, please make sure that your question(s) has not already been asked – and answered – before posting. It is up to the companies to read, comprehend, and comply with ALL rulings posted on the FAQ board.

WEIGHT RESTRICTIONS

NEW FOR 2022!!! No Size Measurement

In light of some of the environments in which the ROVs will be operating, an ROV weight requirement has been included in the request for proposals (RFP). Lighter vehicles will be given special consideration and vehicles above a certain weight will not be considered. Size of the ROV will be limited by a 1-meter square hole in the ice which ROVs must launch through and a 1 cubic meter docking station the ROV must pilot into.

All weight measurements will include the vehicle, all tools and components and the tether. The following will NOT be included in the weight measurement:

- The topside control system and 1 meter of tether going into the control system
- The vertical profiling float
- Any independent sensors if removable from the ROV

Vehicles will be weighed in the on-deck circle 15 to 20 minutes prior to the company’s product demonstration run. Note that the vehicle will be weighed before EACH product demonstration run. The weight bonus, if any, will be added to each product demonstration score.

Weight measurements will be conducted using a digital scale. In addition, companies must be able to personally transport the vehicle and associated equipment to the product demonstration station and to the engineering presentation room. ROV systems must be capable of being safely hand launched.

Competition officials will use the following chart to award points for weight:

Weight (in air)	
< 20 kg	+10 points
20.01 kg to 28 kg	+5 points
28.01 kg to 35 kg	+0 points

Vehicles greater than 35 kg in weight will not be allowed to compete in the product demonstration.

Weight Protocol

Only the six designated product demonstration company members will be allowed into the on-deck circle during and after the weigh in. Once a company’s vehicle has been weighed, it must remain there until the company moves to its product demonstration station. Companies that detach equipment from

the vehicle may not re-install that equipment until the 5-minute set up period. At that time, companies may replace any items that were detached for the measurement, but no new equipment (i.e., equipment that was not included in the weight measurements) may be added to the vehicle. If it is discovered that a company added equipment that was not included in the measurements, the company will not be permitted to compete in that product demonstration run.

Videos showing simulated weight measurements are posted [here](#).

PRODUCT DEMONSTRATION

NOTE for 2022!!!

At the start of the 15-minute product demonstration period, companies must launch their vehicle through a simulated 1-meter square hole in the ice at the surface, side of the pool. The hole in ice will be constructed from ½-inch PVC pipe. Companies are not required to return to the surface through the hole in the ice. Only those product demonstration items being returned for Task 3: Antarctica Then and Now, must be returned through the hole in the ice.

TASK 1: Marine Renewable Energy

UN Sustainable Development Goals:

- **#7 Affordable and Clean Energy**
- **#12 Responsible Consumption and Production**

This task involves the following steps:

1.1 Replacing a damaged section of an inter-array power cable

- **Conducting a visual inspection of the cable – 5 points**
- **Cutting the cable on both sides of the damaged section – 10 points**
- **Removing the damaged section of cable – 5 points**
- **Installing a new section of cable – 10 points**
- **Securing the new section of cable in place with wet-mateable connectors – 5 points each, 10 points total**

1.2 Replacing a damaged buoyancy module on an inter-array cable of a floating offshore wind turbine

- **Removing the failed buoyancy module**
 - **Releasing the clamp – 5 points**
 - **Recovering the failed buoyancy module – 5 points**
- **Attaching a new buoyancy module**
 - **Attaching the new buoyancy module – 5 points**
 - **Securing the clamp – 5 points**

1.3 Monitor the environment

- **Deploying a hydrophone to detect and record the presence of marine mammals**
 - **Deploying the hydrophone in a designated area – 5 points**
 - **Recovering the hydrophone to evaluate data – 5 points**
- **Removing a ghost net caught on the wind turbine's substructure**

- Pulling a pin – 10 points
- Removing the ghost net from the water – 5 points

1.4 Piloting into “resident ROV” docking station

- Autonomous docking – 15 points
- Manually docking – 5 points

Total points = 100 points

Product Demonstration Notes:

Companies must complete the steps of Task 1.1: Replacing a damaged section of an inter-array power cable in order. Companies may not skip any steps of this task. Companies must do Task 1.4 Pilot into “resident ROV” docking station as the final task. Once companies have completed Task 1.4, the production demonstration time ends, and no other points may be scored.

Task 1.1 Replacing a damaged section of an inter-array power cable

The steps of this task must be done in order. Companies cannot proceed to the next step until they have successfully completed the previous step. Companies must first complete a visual inspection of the cable to identify damage. The cable will be simulated by three 75 cm lengths of ½-inch pipe held at least 30 cm above the bottom of the pool in cradles created from 1 ½-inch PVC tees cut in half lengthwise. The ends of each section of cable will have a 1-inch end cap covered with Velcro hooks, which will help to secure the simulated wet-mateable connectors of the new section of cable in place. Damage will be simulated by a spot of [brown](#) paint, at least 1.5 cm in diameter. There will only be one damaged spot on the cable, but it may be located on the underside of the cable. The damaged spot will not be hidden by a cradle. Companies will receive 5 points when they successfully identify the damaged section of cable. Successfully identifying the damaged section of cable is defined as showing the station judge the brown painted spot on a video monitor.

Once the damaged section has been identified, companies must simulate cutting both sides of the cable by pulling [pins](#). Companies will receive 5 points for successfully pulling each pin, 10 points total. Successfully pulling the pins is defined as a pin no longer in contact with the ½-inch pipe of the cable. The pins are not considered debris and may be left in the pool at the end of product demonstration time.

Once the damaged section of cable has been successfully cut, companies must return the damaged length of cable to the surface. Companies may return the section of cable to the surface by any method, including attaching a line to the section of cable and pulling the cable (but not the ROV) to the surface by hand. Companies will receive 5 points when the damaged section of pipe is successfully returned to the surface. Successfully returning the damaged section of pipe to the surface is defined as the damage section removed from the water and placed on the pool deck.

The section of cable will weigh less than 10 Newtons in water.

Once the damaged section of the cable has been removed from the pool, a new section of cable must be installed. The new section of cable will be available on the surface, side of the pool. The new section of

cable will be simulated by a 73 cm length of ½-inch PVC pipe with two wet-mateable connectors slid over each end of the pipe, one on each side. The wet-mateable connectors will be simulated by 1-inch x 1 inch x ½-inch tees that have Velcro loops on the inside edge. Additional Velcro loops, 7 cm wide, will be located 8 cm from both ends of the 73 cm length of pipe. The Velcro loops around the pipe will provide friction with the Velcro loops inside the wet-mateable connectors to keep the connectors from sliding off during transport. Two additional wet-mateable connectors will be available on the surface, side of the pool in case a wet-mateable connector does slide off during transport.

Companies will receive 10 points when they successfully install this new section of cable. Successfully installing this new section of cable is defined as the ½-inch length of PVC pipe positioned in both cradles that once held the damaged section of cable. The ends of the pipe must be within the 75 cm gap between the sections of cable that remain on the bottom, and the wet-mateable connectors must be over each end of the pipe.

Once the new section of cable has been successfully installed, companies must secure the new section of cable in place by connecting the wet-mateable connectors to the ends of the old cable. The 1-inch tees simulating the wet-mateable connectors will slide over the ½-inch PVC pipe of the new cable and the Velcro loops on each end of the tee will attach to the Velcro hooks on the 1-inch end caps of the old sections of cable to secure it in place. Companies will receive 5 points each, 10 points total when the new section of cable is secured in place with wet-mateable connectors. Successfully securing the new cable in place is defined as the Velcro loops of the wet-mateable connector tees secured to the Velcro hooks on the end caps on the old section.

Task 1.2 Replacing a damaged buoyancy module on an inter-array cable of a floating offshore wind turbine

Companies must replace a failed buoyancy module attached to an inter-array cable and replace it with a new buoyancy module. The inter-array cable will be simulated by a length of ½-inch PVC pipe painted blue and held at least 30 cm above the bottom of the pool by a length of ½-inch PVC pipe. This section of the inter-array cable will be an extension of the inter-array cable from Task 1.1. Both the failed buoyancy module and the new buoyancy module will be simulated by 2-inch tees with an opening cut lengthwise, which is connected by Velcro to a length of foam flotation.

Companies must remove the failed buoyancy module from around the cable by releasing a clamp. Releasing the clamp will be simulated by rotating the module 180°. A short handle will be attached to the middle opening of the 2-inch tee. At the start of the product demonstration, it will be pointed down. Companies must rotate the handle until it is pointed upwards, which will release the damaged buoyancy module from the cable. Companies will receive 5 points for successfully releasing the clamp and removing the failed buoyancy module from the cable. Successfully releasing the clamp and removing the failed buoyancy module is defined as the no part of the buoyancy module in contact with the ½-inch PVC pipe of the cable.

The buoyancy module will be positively buoyant in water.

The buoyancy module will have less than 5 Newtons of buoyant force in water.

Once the failed buoyancy module has been removed from the cable, it must be recovered. Companies will receive 5 points for successfully recovering the failed buoyancy module. Successfully recovering the failed buoyancy module is defined as the ROV returning the buoyancy module to the surface, side of the pool and the failed buoyancy module being placed on the pool deck.

Companies must also attach a new buoyancy module to the cable. An 8 cm x 1 cm length of Velcro hooks will be located on the underside of the cable section painted blue. A new buoyancy module will be on the surface, side of the pool. The new buoyancy module will have an 8 cm x 1 cm length of Velcro loops on the inside edge of the foam flotation. Companies must attach the new module to the pipe and secure the clamp by connecting the Velcro loops on the module to the Velcro hooks on the bottom of the pipe. Companies will receive 5 points when the buoyancy module is successfully attached to the cable. Successfully attaching the module to the cable is defined as the foam flotation inside the 2-inch tee completely around the ½-inch pipe of the cable. Companies will receive 5 additional points when they successfully secure the clamp. Successfully securing the clamp is defined as the Velcro loops of the new buoyancy module connected to the Velcro hooks on the underside of the ½-inch PVC pipe. The new buoyancy module must also stay in place on the PVC pipe once it has been released by the ROV.

Task 1.3 Monitoring the environment

Companies must deploy a hydrophone into a designated area on the bottom of the pool. The hydrophone will be simulated by a 20 cm length of ½-inch PVC pipe. The hydrophone will be attached to both a buoyancy module constructed from 2-inch PVC pipe and a weighted base constructed from ½-inch PVC pipe by lengths of rope. The designated area will be a 40 cm x 40 cm square painted orange. Companies will receive 5 points when they successfully place the hydrophone within the designated area. Successfully placing the hydrophone within the designated area is defined as the weight of the hydrophone completely within the designated area. The weight may not be on top of any portion of the ½-inch PVC pipe of the designated area.

The hydrophone must be recovered after being deployed at the designated area for 5 minutes. When companies successfully deploy the hydrophone, the station judge will note the time on the side of the company product demonstration score sheet. Companies may only recover the hydrophone after 5 minutes of water time. Companies will receive 5 points when they successfully recover the hydrophone. Successfully recovering the hydrophone is defined as the hydrophone deployed in the water for 5 minutes, after which time it is returned to the surface side of the pool and placed on the pool deck.

The hydrophone will weigh less than 5 Newtons in water.

Companies must remove a ghost net from the wind turbine's substructure. The net will be constructed from ½-inch PVC pipe and [decorative cloth netting](#) will be attached to the framework with cable ties. The net will be positively buoyant and secured by a rope to a weighted part of the inter-array cable. Companies must pull a pin to simulate cutting the rope and releasing the net from the weight on the bottom. Companies will receive 10 points when they successfully pull the pin. Successfully pulling the pin is defined as the pin no longer in contact with the PVC pipe or netting of the ghost net. After pulling the pin, companies may leave it on the bottom or return it to the surface. The pin is not considered debris.

Once companies have pulled the pin, they must return the ghost net to the surface, side of the pool. Companies will receive 5 points when they successfully remove the ghost net from the water. Successfully removing the ghost net is defined as the PVC pipe and netting completely out of the water and placed on the pool deck. Neither the pin nor the rope holding the net need to be removed from the pool.

The ghost net will have less than 5 Newtons of buoyant force in water.

Task 1.4 Piloting into “resident ROV” docking station

At the end of the product demonstration run, instead of returning to the surface, side of the pool companies must pilot their ROV into a “resident ROV” docking station. The docking station will be 1 meter cubed and constructed from ½-inch PVC pipe. As their final product demonstration task, companies must maneuver their vehicle into this docking station. After entering the docking station, the product demonstration time ends and companies can no longer attempt tasks or receive points. Companies that need to return items to the surface, side of the pool should do so before docking.

Companies may choose to pilot into the “resident ROV” docking station autonomously or manually.

Companies that choose to pilot into the station autonomously are tasked with creating software that will allow their vehicle to autonomously enter the docking station. Companies will receive 15 points when they successfully pilot autonomously into the docking station. Successfully piloting autonomously into the docking station is defined as the ROV positioned completely outside of the docking station, the company going hands free from the controls, and the ROV moving on its own so that the entire ROV is completely inside the docking station.

Companies may choose to pilot into the docking station manually. Companies will receive 5 points when they successfully dock manually in the station. Successfully docking manually in the station is defined as the ROV under control of the pilot moving until the entire ROV completely inside the docking station.

ADDITIONAL CHALLENGE FOR COMPANIES ADVANCING TO THE WORLD CHAMPIONSHIP!!!

Companies advancing to the World Championship will be challenged to pilot their ROVs to push a button at the back of the docking station. Pushing this button will illuminate an LED on the surface to indicate the ROV has successfully docked in the station. The button will be in the center of the back wall of the docking station, at least 30 cm from the bottom and 50 cm from each side wall of the docking station. The button will be simulated by a length of ½-inch PVC pipe with an end cap on one end inserted into a ¾-inch by ½-inch tee. The end cap will be painted red. Pushing on the ½-inch end cap will move a magnet within range of a magnetic reed switch, which is connected to a power source and LED on the surface. At the World Championship, successfully docking in the station is defined as the entire ROV completely inside the docking station and the LED illuminated at the surface control station. Companies choosing to autonomously pilot into the control station must have the ROV push this button without any input from the pilots.

Regional competitions may offer to the opportunity to illuminate an LED at the surface station. EXPLORER class companies participating in a regional competition should contact their [regional coordinator or visit their regional contest's website](#) to determine if this challenge will be offered at your regional.

TASK 2: Offshore Aquaculture and Blue Carbon

UN Sustainable Development Goals:

- #2 Zero Hunger
- #13 Climate Action
- #14 Life Below Water

This task involves the following steps:

2.1 Inspecting an offshore aquaculture fish pen

- Inspecting the netting to identify damaged areas
 - Flying a transect line to identify damaged areas
 - Autonomously inspecting – 25 points
 - Manually inspecting – 10 points
 - Identifying and counting damaged net areas – 5 points
- Repairing a damaged section of netting – 10 points
- Removing marine growth
 - Removing encrusting marine growth - 5 points
 - Removing algal marine growth – 5 points

2.2 Maintaining a healthy environment

- Manage mortality by removing “morts” from the fish pen
 - Using AI to differentiate “morts” from live fish – 10 points
 - Collecting a “mort” – 5 points
 - Inserting “mort” into the collection tube – 5 points

2.3 Measure fish size

- Determine the average size of the fish cohort within 2 cm – 15 points
- Determine the biomass of the fish cohort – 5 points

2.4 Farm seagrass

- Prune an existing seagrass bed – 5 points
- Plant a new seagrass bed – 5 points

Total points = 100 points

Product Demonstration Notes:

Companies must inspect the netting to identify damaged areas before repairing the damaged section. Otherwise, companies may complete the steps of Task 2 in any order.

Task 2.1 Inspecting an offshore aquaculture fish pen

Companies must inspect an offshore aquaculture fish pen. The fish pen will be simulated by a large (up to 2.5 meter by 1.8 meter) sheet of plastic mesh. The plastic mesh will be connected to a ½-inch PVC frame which will be suspended in the water column at a distance of less than 30 centimeters from the pool wall. The plastic mesh netting will be divided by the PVC framework into four sections: top left, top right, lower left and lower right. Red [rope](#) will form a transect line moving horizontally and vertically along the fish pen. Companies must follow the red transect line from one end to the other to inspect the fish pen.

Companies may choose to inspect the fish pen netting autonomously or manually.

Companies that choose to inspect the fish pen netting autonomously are tasked with creating software that will allow their vehicle to autonomously fly along the red transect line to inspect the fish pen netting by flying along the red rope transect line from one end to the other. Companies that successfully inspect the fish pen netting using an autonomous control program will receive 25 points. Successfully inspecting the netting autonomously is defined as the control program flying the vehicle from the starting point to the ending point by following the red line without any input from the company members. Companies may start at either end of the red rope line. No company member should be touching the controls for the entire transect. A tether manager may hold the tether but cannot guide the vehicle in any way. The station judge must be able to see the vehicle moving through the water and following the red rope line from the start to the end on a video screen. The vehicle **MUST** be close enough to the netting that only one length of red rope is visible in the video screen; other sections of the red rope, (at least 30 cm above, below or beside) must not be visible. If the vehicle fails to autonomously follow the red rope, companies may reposition their vehicle at the starting point and try again. There is no limit to how many times the company may try to autonomously follow the red rope line.

Companies that choose to inspect the fish pen netting manually must pilot their vehicle to follow the red rope line from start to finish. Companies that successfully inspect the fish pen netting manually will receive 10 points. Successfully inspecting the fish pen netting manually is defined as the vehicle, under control of the pilot, flying along the red line from start to finish. The station judge must be able to see the vehicle moving through the water and following the red rope line on a video screen. The vehicle **MUST** be close enough to the netting that only one length of red rope is visible in the video screen; other sections of the red rope, (at least 30 cm above, below or beside) must not be visible. There is no limit to how many times the company may try to manually fly along the red transect line to inspect the fish pen. A video demonstrating the fish pen netting inspection can be found [here](#).

The red line will be constructed on the mesh as follows:



The red rope line on the fish pen netting. The gray lines will be the PVC framework.

As they fly their vehicles follow the red rope line, companies will inspect the netting for damaged areas. Damaged areas will be simulated by holes, i.e., sections cut out of, the mesh netting. Damaged areas will be rectangular and between 15 cm and 30 cm by 5 cm to 10 cm. There will be two to five damaged areas in the fish pen netting. All damaged areas will be within 20 cm of the red rope line and fully within one quadrant (top left, top right, lower left, lower right). The quadrants will be [labeled](#) TL, LL, TR, and LR. Companies must count the number of damaged areas and report the quadrants in which they are located. Companies will receive 5 points for successfully reporting both the number of damaged areas and in which quadrants they are located. Successfully reporting is defined as informing the station judge how many damaged areas there are and in which quadrants the damaged areas are located. For example, the company would inform the judge there are a total of three areas, two of which are located in the top left quadrant and one that is located in the lower left quadrant.

Companies must also repair one of the damaged areas of netting. A patch for repairing the net will be available on the surface, side of the pool. The patch will be constructed of a 40 cm x 20 cm rectangle of ½-inch PVC pipe with mesh netting attached. A #310 U-bolt will be attached to the PVC pipe to act as a grab point. Two #6 screw hooks will be used to attach the patch to the fish pen netting. Companies must position the patch to completely cover the damaged area of the fish pen netting. Companies will receive 10 points when they successfully repair the damaged area of the netting. Successfully repairing the damaged area is defined as the patch completely covering the entire damaged area and remaining attached to the fish net netting after the vehicle has released it. The station judge must not be able to see any damaged area outside of the patch once the patch has been released by the ROV.

Companies must remove marine growth from the mesh netting of the fish pen. Encrusting marine growth will be simulated by a ½-inch PVC cross. A 2 cm x 2 cm square of Velcro loops will be attached to the ½-inch cross. The mesh netting of the pen will have a 1.0 cm x 0.8 cm square of Velcro hooks attached to it. The cross will be attached to the mesh netting of the pen by this Velcro connection. Companies will receive 5 points for successfully removing the encrusting marine growth from mesh netting. Successfully removing the encrusting growth is defined as the ½-inch PVC cross no longer in contact with the plastic mesh. The encrusting growth is not considered debris and may be left in the pool at the end of product demonstration time.

Companies must also remove algal marine growth. The algal marine growth will be simulated with pipe cleaners. The pipe cleaners will have a loop at one end to act as a grab point. The other end of the pipe cleaners will be inserted into holes drilled into the ½-inch PVC pipe of the framework of the netting. There will be three algal marine growths on one section of pipe. All three algal growths will be within 50 cm of each other. Companies will receive 5 points for successfully removing all three algal marine growths from the netting. Successfully removing the algal growth is defined as the pipe cleaners no longer in contact with the 1 ½-inch PVC pipe of the netting framework. All three algal growths must be successfully removed to receive points. The algal marine growth is not considered debris and may be left in the pool at the end of product demonstration time.

Both the encrusting and algal growths will be located at least 20 cm from any damaged area of the fish pen netting.

Task 2.2 Maintaining a healthy environment

Companies must maintain a healthy environment by removing dead fish “morts” from the pen.

Companies are tasked with creating software that can determine the difference between morts and live fish. During the 5-minute set up for the product demonstration run, companies will download a video showing live fish and morts in offshore aquaculture fish pen. During the product demonstration run, companies can use their software to evaluate this video and highlight morts with a red box. Companies will receive 10 points when their program successfully differentiates between live fish and morts. Successfully differentiating between live fish and morts is defined as showing the station judge on a video screen the downloaded video with all morts highlighted in a red box. Multiple red boxes can be used to highlight individual morts, or a group of morts can all be highlighted by the same red box. Companies can choose to skip this step and move directly to collecting morts.

Practice videos will be uploaded to the [MATEROVCompetition EXPLORER Challenge](#) website. Companies can use these videos to train their algorithms.

Morts will be simulated by [rubber fish](#). Weight will be added to the fish to make it negatively buoyant. One mort will be located in the product demonstration area. Companies must collect this mort from the bottom and insert it into a collection tube for removal to the surface. The collection tube will be simulated by a 5-gallon bucket which will be weighted and sitting upright on the bottom of the pool adjacent to the “resident ROV” docking station. Companies will receive 5 points when they successfully collect the mort. Successfully collecting the mort is defined as the rubber fish under control of the ROV

and no longer in contact with the bottom of the pool. Companies will receive an additional 5 points when they successfully insert the mort into the 5-gallon bucket collection tube. Successfully inserting the mort into the collection tube is defined as the rubber fish no longer in contact with the ROV and inside the open top of the 5-gallon bucket.

The rubber fish mort will weigh less than 5 Newtons in water.

Task 2.3 Measure fish size

Companies must measure the length of three fish and determine the average length. The three fish will be simulated by [rubber fish](#). The rubber fish will be cut into two pieces and elongated with a variable length of ½-inch PVC pipe. The fish will be positively buoyant and suspended approximately 1 meter off the bottom of the pool by rope or line. Each fish will be between 35 cm and 65 cm in length.

Companies must measure the length of all three fish and determine the average length. Companies will receive 15 points for successfully calculating the average length of the three fish. Companies should explain to the judge how they plan to measure the length of each fish before proceeding with their measurements. Successfully calculating the average length of the three fish is defined as informing the station judge of the average length and that length estimate being within 2 cm of the actual average length. Companies only get one attempt to determine the average length of the fish. If they are not within 2 cm, companies may not try again.

The three fish suspended in the water column may move, twist, and turn due to currents in pool. Currents may be intentionally created in the pool to create movement of the simulated fish.

Companies must next calculate an estimate of the biomass of the fish cohort (every fish being harvested in the pen). After measuring the fish and determining the average length (correctly or incorrectly), companies will be given the actual average length of the fish. Companies will use the average fish length and the following equation to calculate the biomass of the cohort:

$$M = N * a * L^b$$

- M is the Biomass (kilograms)
- L is the average length (centimeters)
- N is the number of fish in pen
- a and b are determined by species and environmental conditions.

The values for N, a and b will be provided to companies at the product demonstration station. Companies that do not attempt to measure the average fish length will not have the opportunity to calculate the biomass of the cohort. Companies will receive 5 points when they successfully calculate the biomass of the cohort in the pen. Successfully calculating the cohort biomass is defined as informing the station judge of the calculated cohort biomass estimate and that estimate being within 5 kilograms of the actual value. Companies have only one attempt to calculate the cohort biomass. If they are not within 5 kilograms, companies may not try again. Companies should report the cohort biomass in kilograms.

For example, if the average length of the fish is 44 cm, $N = 20,000$, $a = 0.0021$, and $b=3.561$, companies would calculate the cohort biomass as 29,894 kg.

Task 2.4 Farm Seagrass

Companies are also required to farm seagrass. This includes pruning existing seagrass beds and planting new ones. Seagrasses will be simulated by green foam sheets attached to ½-inch PVC pipe; the seagrass bed for planting will also include plastic mesh attached to the ½-inch PVC pipe. The simulated seagrass bed that requires pruning will be located on the bottom of the pool. The simulated seagrass bed for planting will be located on the surface, side of the pool. Pruning will be simulated by collecting a simulated seagrass bed from the bottom of the pool. Companies must prune seagrass from the bottom and return it to the surface. Companies will receive 5 points for returning the seagrass sample to the surface. Companies must also plant a new seagrass bed in a designated area. The designated area will be a 41 cm square of ½-inch PVC pipe painted green. Companies will receive 5 points for successfully planting the new seagrass bed. Successfully planting the seagrass is defined as the entire length of ½-inch PVC completely within the designated area. No part of the seagrass may be on top of or outside of the green square.

TASK 3: Antarctica Then and Now – Endurance22 and MATE Floats!

UN Sustainable Development Goal:

- #13 Climate Action

This task involves the following steps:

3.1 MATE Floats!

- Recovering a GO-BGC float to conduct diagnostics
 - Determining the location where the float will next surface – 5 points
 - Recovering the float – 10 points
- Designing and constructing an operational vertical profiling float
 - Prior to the competition, building a float – 5 points
 - Deploying the float in the designated area – 5 points
 - Float completing vertical profiles
 - Float completes two profiles– 25 points
 - Float completes one profile– 15 points

3.2 Endurance22

- Finding and mapping the location of the *Endurance*
 - Flying a transect over the area of the wreck – 10 points
 - Mapping the wreck – 5 points
- Creating a photomosaic of the wreck
 - Collecting images of all sections – 5 points
 - Autonomously creating the photomosaic – 20 points
 - Manually creating the photomosaic – 10 points
- Measuring the length of the wreck from bow to stern
 - Within 10 cm of the true distance – 10 points

- **Within 10.1 to 20 cm of the true distance – 5 points**
- **Not within 20 cm of the true distance – 0 points**

Total points = 100 points

Product Demonstration Notes:

Once the GO-BGC float has been recovered, companies may no longer receive points for determining the location where the float will next surface. Companies must complete their calculations prior to retrieving the GO-BGC float in order to receive points for determining the location of the float.

NOTE for 2022!!!

The GO-BGC float must be returned to the surface through the hole in the ice. Returned/recovered items from other tasks do not need to be returned through the hole in the ice and can be recovered anywhere along the side of the pool.

Task 3.1 *MATE Floats!*

Companies must determine the location within the polynya where the GO-BGC float will next resurface. Companies will be provided with a grid map showing the location where the float previously surfaced. Companies will also be provided with:

- Current speed
- Current direction
- Time (in hours) until next surface event

Companies must use this data to plot on the grid map the square where the GO-BGC float will next surface. Companies will receive 5 points for successfully plotting the location where the float will next surface. Successfully plotting the location is defined as plotting the location within the exact square of the actual location on the grid map. Companies must show this plot to the station judge prior to end of the product demonstration run. Once time has expired, no more calculations can be made.

Companies will be provided with a paper copy of the grid map in their team folder or as they begin set up at the product demonstration station. Companies may also choose to download a copy of the map (a PNG file will be provided) and plot the location on their digital map.

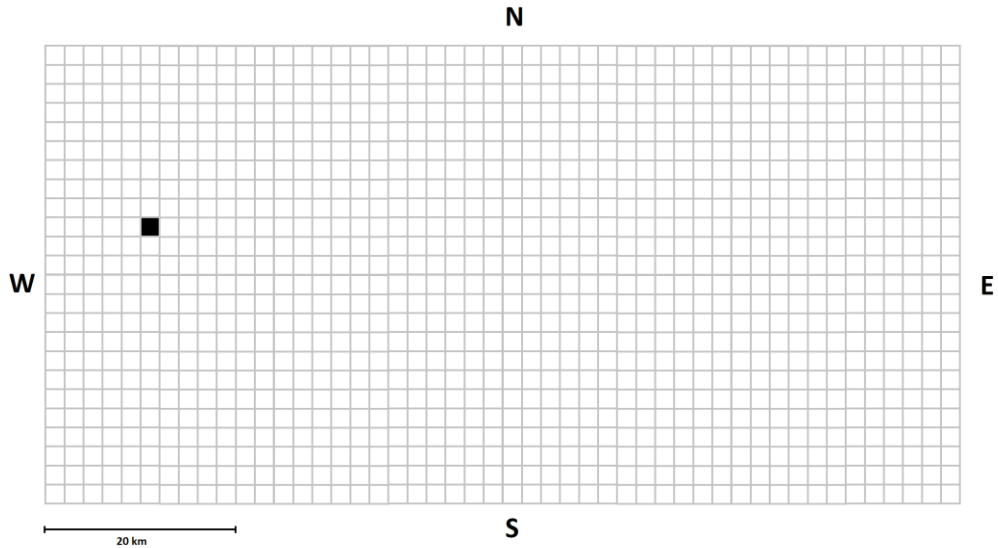

A blank map with the grid square where the GO-BGC previously surfaced marked (black square).

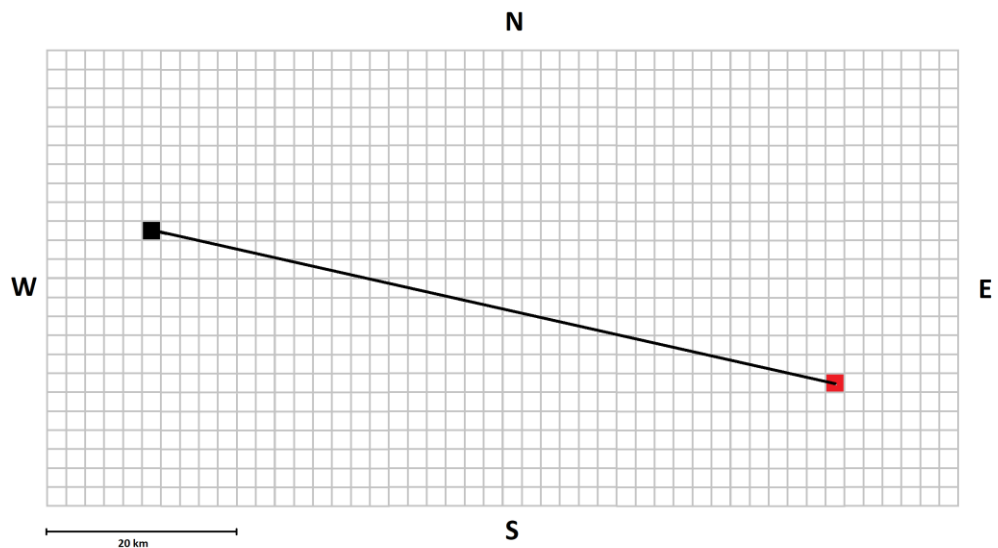

In this example, companies would be provided with the following information: the current is moving at 103° at 0.143 m/s. The float will resurface 144 hours later. Using that data, companies can determine that the float moved 74.13 km at 103° . Calculations show that translates into movement of 72.39 km east, and 16.71 km south. The plotted grid square is colored red. Note that each square represents 2 km square.

Companies must also recover the GO-BGC float. The float will be constructed from 2-inch PVC with an end cap / knock out cap attached to one end. Flotation inside the pipe will make the float positively buoyant. The GO-BGC float will be corralled in a 0.5-meter square PVC frame floating on the surface of the water. Companies will receive 10 points when they successfully recover the float. Successfully

recovering the float is defined as the GO-BGC float removed from the water through the hole in the ice and placed on the pool deck.

The GO-BGC float will have less than 10 Newtons of buoyant force in water.

Prior to the competition, companies must build a float capable of completing a vertical profile (i.e., travel from the surface to the bottom and back to the surface). EXPLORER class companies must design their float with a buoyancy engine. A [buoyancy engine](#) moves fluid from inside an internal reservoir to a flexible bladder located externally. This displaces seawater, changing the density of the float.

Companies will receive 5 points for designing and building a float. Companies must submit a one-page document outlining their float design, detailing its operation, including the design of its buoyancy engine, and demonstrating that it does not violate any safety rules. This document must be submitted in advance of the competition. EXPLORER class companies attending a regional may or not be required to submit this document. [Contact your regional coordinator or visit your regional contest's website](#) to determine if you must submit your float design document prior to the competition. See DOC-004 for more information. IF REQUIRED BY THE REGIONAL COMPETITION, COMPANIES MUST SUBMIT THEIR FLOAT DOCUMENTATION OR THEY WILL NOT BE RECEIVE POINTS FOR BUILDING THE FLOAT. Companies MUST present a copy of the float documentation to the station judges.

After submitting the float documentation to the station judge, the ROV may deploy the float into the designated area. The designated area will be a 0.5-meter square PVC frame floating on the surface of the water. It will be different from, but adjacent to the PVC square holding the GO-BGC float to be recovered. Companies will receive 5 points when they successfully deploy their float in the designated area. Successfully deploying the float is defined as the float no longer in contact with the ROV and the top of the float breaking the surface of the water inside the 0.5-meter designated area.

Once the float has been deployed, it should attempt to complete two vertical profiles. A vertical profile is defined as any part of the float on or above the surface, descending in the water column until any part of the float touches the bottom, then ascending to and breaking the surface once again. After descending, the float does not need to break the surface inside the designated area. Companies must use a buoyancy engine to move their float through the water. A buoyancy engine is defined as moving air or liquid from inside the float to a bladder outside the float, changing the volume and thus the density of the float. Companies will receive 15 points for completing their first vertical profile and 10 additional points for completing their second vertical profile, 25 points total.

The float must be less than 1 meter in overall height. The float may not have a diameter/length/width greater than 18 cm.

The company-built float must move independently from the ROV. The float must operate independently; it may not be connected to the shore by a tether. The float will operate as a non-ROV device (see [3.3.1 Non-ROV Device Power Specifications](#)) for additional rules on powering a non-ROV devices.

Task 3.2 Endurance22

Companies must fly a transect line over the search area for the *Endurance*. The search area of the wreck will be simulated by a ½-inch PVC pipe rectangle 3 meters long by 1 meter wide. A grid of 8 rectangles, 75 cm x 50 cm, will be created within the search area using [Pink Braided Nylon Mason’s Line](#). The 3-meter lengths of PVC pipe that make up the “top” and “bottom” of the area will be painted blue.

The 1-meter “ends” of the area of the wreck will be divided into three 33 cm sections. The middle 33 cm section will be painted black, while the two outer sections will be painted yellow.

An additional 3-meter length of PVC pipe will be located 50 cm from the top and bottom of the search area. These additional lengths of pipe will be painted red. The search area will be located on the bottom of the pool.

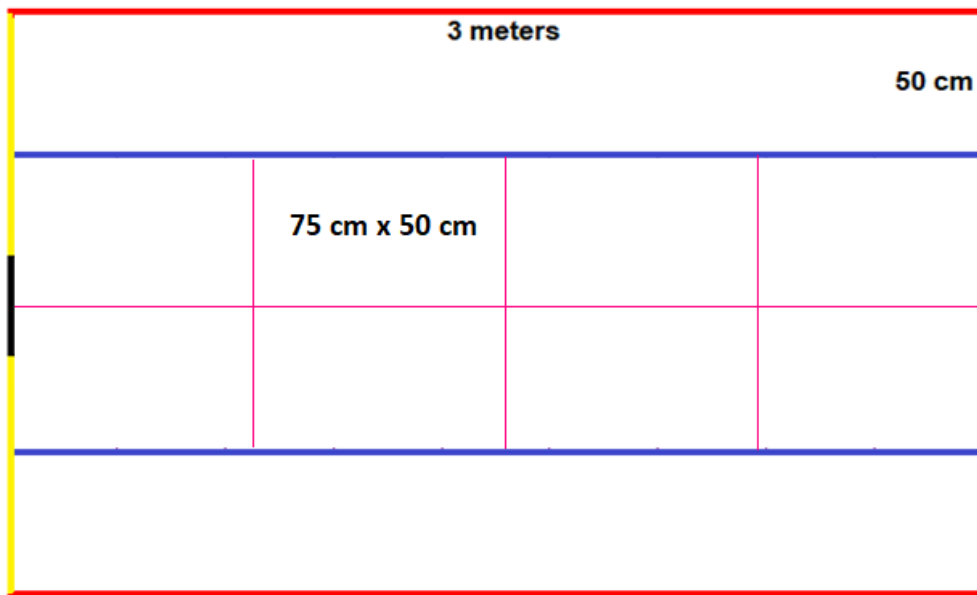

A diagram of the search area. The blue, red, yellow, and black lines are painted ½-inch PVC pipes. The pink lines are braided Mason’s Line.

Companies must fly a transect line over the search area, displaying the video image of the transect on a display screen for the station judge. Successfully flying a transect over the search area is defined as starting at one end of the transect and moving to the other end of the transect. Starting at one end of the transect is defined as the ROV directly above the black length of PVC pipe on either end of the wreck site.

The ROV must also remain at a certain height over the search area during the transect. While flying the transect over the search area, both blue painted PVC pipes must be in the video display at all times and neither red pipe may be visible in the video display. If any section of red pipe is seen in the video display, or both blue pipes are not seen in the video display at all times, the ROV has failed to successfully fly the transect.

A video showing successful and unsuccessful flying of the transect line can be seen [here](#).

Companies must position their vehicle above the black PVC pipe on one end of the search area and fly a transect over the search area. Companies that successfully fly a transect over the search area will receive 10 points. Successfully flying the transect is defined as the ROV positioned above the black PVC pipe on one end of the search area and moving the vehicle to a position above the black PVC pipe on the other end of the search area. The station judge must be able to see the vehicle moving through the water and must be able to see both blue PVC pipes, but neither of the red pipes, in the video display at all times. Companies that do not successfully fly the transect may reposition their ROV above a black PVC pipe and try again. There is no limit to how many times the company may attempt to fly the transect. Either end of the search area may be used as the starting point for flying the transect.

Companies must also map the wreck. The wreck will be created from ½-inch PVC pipe painted [brown](#). The wreck will be located completely within the search area. The wreck will occupy some, but not all, of the rectangles. Companies must map the locations of the wreck on a video display screen. Companies should design a display with 8 squares, arranged in a four x two grid copying the orientation of the search area grid as it is positioned in the pool. Companies should draw an image of the wreck in the map. Companies will receive 5 points for successfully mapping the wreck. Successfully mapping the wreck is defined as the diagram of the wreck drawn into every rectangle that contains a portion of the wreck. Companies only get one opportunity to map the wreck. Companies that cannot successfully map the wreck on their first try will not receive points for mapping.

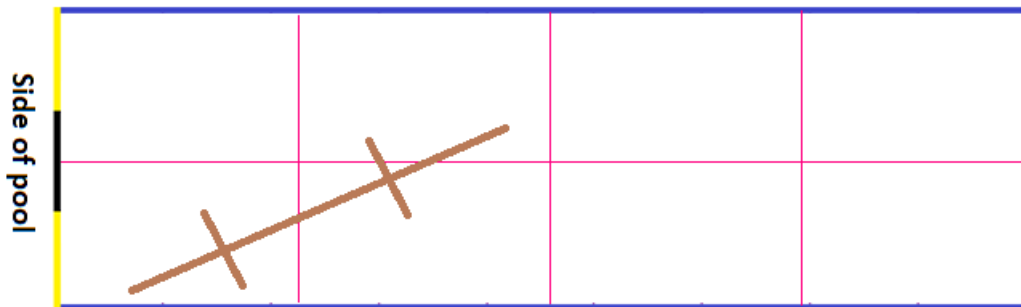

Top: Search area with the shipwreck.

The map should identify which edge is the side of the pool.

Benthic species (glass sponge, sea stars and brittle stars) may occupy some rectangles. These species do not need to be drawn on the map.

Flying the transect and mapping the wreck are separate tasks. Companies may choose to do the two tasks simultaneously or may choose to do them individually.

Companies must create a photomosaic of the wreck site. Companies must take eight images of the wreck site, one of each rectangular section. Each image should contain only one entire rectangle. The image may show parts of adjacent rectangles, but not an entire rectangle other than the target imaged. Companies will receive 5 points when they have successfully collected all eight images. Successfully collecting all eight images is defined as showing the station judge a separate image of each of the eight

rectangles. Each rectangle should show the complete rectangle, but only parts of the adjacent rectangle.

Companies may choose to stitch together the images into a photomosaic autonomously or manually.

Companies that choose to stitch the images into a photomosaic autonomously are tasked with creating software to “stitch” the images together. Companies may manually pilot their vehicle to any location to take the eight individual images, but the program must “stitch” the images into a photomosaic. Companies that successfully “stitch” the images together autonomously will receive 20 points. Successfully “stitching” the images together autonomously is defined as no input from company members other than taking the images. The photomosaic must be compiled and shown to the station judge within the 15-minute product demonstration period. Companies may transfer the eight images to another device (e.g., a laptop computer or tablet) at the product demonstration station to have that device “stitch” the images together. Companies may not transfer the images to anyone not at the product demonstration station; doing so will result in disqualification. **All work must be done by company members or devices at the product demonstration station.** Companies transferring images to another device should inform the station judge of their intended actions.

Companies that choose to stitch the images into a photomosaic manually will receive 10 points for successfully stitching the images together. Successfully “stitching” the images together manually is defined as a company member at the product demonstration station using a program to physically cut and paste the images into a photomosaic. Art programs such as Photoshop, MSPaint, or others can be used. This photomosaic must be compiled and shown to the station judge within the 15-minute product demonstration period.

Companies attempting to create the photomosaic of the wreck site autonomously are permitted to take screenshots of rectangles and manually transfer them to another device. How a company takes their image and how the images are transferred to the device is up to the company. The images cannot be manipulated prior to being transferred to the device that is stitching them together autonomously. Companies may pilot their vehicle to any location to take a photo, but once taken that photo must be transferred unaltered. Any manipulation of a photo would be considered manual creation of the photomosaic. Minor obstructions (ROV tool, frame) in the photos are allowed, provided the station judge can identify the wreck in the final photomosaic. Once transferred to a device, a software program should then autonomously join the photos into a photomosaic of the wreck site.

Companies must measure the length of the wreck from bow to stern. The wreck of the *Endurance* will be constructed from ½-inch PVC. The bow of the wreck will stick up from the bottom of the pool at a 45° angle, the stern will stick up from the bottom of the pool at a 90° angle. Both the bow and the stern will rise approximately 30 cm off the bottom of the pool. Companies must measure the length of the wreck from the topmost point of the bow to the topmost point of the stern. Companies will receive 10 points if their measurement is within 10 cm of the true distance. Companies will receive 5 points if their measurement is between 10.1 and 20 cm of the true distance. Companies will receive 0 points if their measurement is greater than 20 cm from the true distance.

The wreck of the *Endurance* is a historical site and must be preserved. Therefore, companies will be penalized 5 points each time their ROV comes into contact with the wreck of the *Endurance*, up to a penalty of 25 points total. This includes the ROV tether and other components. If any part of the ROV comes in contact with the, the station judge will inform the company and the company will be penalized 5 points.

PRODUCT DEMONSTRATION RESOURCES

[EXPLORER fish videos](#) will be available to allow companies to train their AI to differentiate morts from live fish.

The [EXPLORER blank grid map](#) will be available for determining the location where the GO-BGC float will next surface.

NOTE for 2022!!!

PRODUCT DEMONSTRATION RESPONSIBILITIES

Companies are responsible for designing, building, and bringing their own operational vertical profiling float. Companies must also design and bring any tools or devices to complete the required MATE product demonstration tasks.

Companies are permitted to create a basket to collect multiple product demonstration items. Any collection basket MUST be included in size and weight measurements. A collection basket is considered debris if still in the pool and not under control of the ROV when product demonstration time ends. Any collection basket must be deployed and returned by the ROV; it may not be pulled to the surface by hand or a surface device.

The MATE ROV Competition will provide all of the remaining product demonstration items.

PART 2: PRODUCT DEMONSTRATION PROP BUILDING INSTRUCTIONS & PHOTOS

The [Product Demonstration Prop Building Instructions & Photos](#) have been made their own, separate document. This document will be released with, but separate from, this competition manual.

PART 3: VEHICLE DESIGN & BUILDING SPECIFICATIONS

1.0 GENERAL

Questions about vehicle design and building specifications, as well as competition rules, should be posted to Competition Help within the MATE Forum Hub (<http://forums.marinetech2.org/>). This

ensures that all companies can view the questions and answers and helps to avoid duplicate questions. That said, companies should make sure that their questions have not already been asked – and answered – before posting. When posting their question, companies should reference the specific specification (e.g. ELEC-002R).

Conventions: All values contained in this document are threshold values unless specifically stated otherwise. All water depths are given in meters (m). All dimensions and measurements utilize SI units.

EXPLORER class companies participating in a regional competition should contact their [regional coordinator](#) or visit their [regional contest's website](#) to find out any specific requirements for your regional.

2.0 SAFETY

Safety is the competition's primary concern and guiding principle. Any system that is deemed unsafe by competition officials will not be allowed to compete. If a safety concern is identified during the initial inspection, companies are permitted to modify their system and have it re-inspected. Companies are permitted to have their vehicle re-inspected twice. If a company fails to pass its third and final safety inspection, it is disqualified from the underwater competition portion of the event. There are NO APPEALS once an ROV has been disqualified.

NOTE for 2022!!!

MATE ROV Competition safety inspectors will be reinforcing the competition's emphasis on safety. Wiring discipline/workmanship (ELEC-023R) and strain relief at both ends of the tether (ELEC-024R) will be areas of particular emphasis. **Companies that do not meet these safety standards will not be permitted to compete in the in-water events.** Additional examples of wiring workmanship will be included in the [2022 Safety Inspection Tutorial](#).

Examples of safety violations from previous ROV competitions include:

- Companies used equipment that did not participate in and/or pass safety inspection
- The electrical SID included in the technical documentation did not show a main fuse.
- The ROV used pneumatics, but the technical documentation did not include a pneumatics diagram.
- The ROV used pneumatics, but the company had not passed the fluid power quiz.

2.1 Job Site Safety Analysis

Each member of the company is encouraged to read [Oceaneering Americas Region HSE Employee Handbook](#), with emphasis placed on the following chapters.

Chapter 1 - Housekeeping

Chapter 9 - Hand Safety

Chapter 11 - Lifting and back safety

Chapter 12 - PPE

Chapter 17 - Tool Safety

- Chapter 24 Electrical Safety
- Chapter 29 - Employee Observation Program
- Chapter 33 - JSEA
- Chapter 37 - Working at Other sights

Job Site Safety Analysis (JSAs)

For companies advancing to the World Championship, 10 points can be earned by creating a JSA and submitting it along with (but as a separate document from) the [Technical Documentation](#).

A **JSA** describes job tasks in step-by-step fashion, identifies associated hazards at each step, and outlines proper hazard controls that minimize the risk of injury or illness to the individual(s) performing that task. JSAs are used extensively by the offshore industry.

For more information and examples, companies can visit the following web sites:

- <http://ehs.berkeley.edu/how-do-i-write-and-update-job-safety-analysis-jsa>
- www.safetyworksmaine.com/safe_workplace/safety_management/hazard_analysis.html

POTENTIAL HAZARDS

DESCRIBE JOB STEP <small>(List the natural steps of the job. Do not make the steps too broad or too fine)</small>	POTENTIAL HAZARDS <small>(What are the potential hazards identified at this part of the job steps)</small>	RECOMMEND RISK CONTROL MEASURES <small>(describe how the identified hazards can be eliminated or reduced)</small>	RESPONSIBLE PERSON (S) <small>(implementing control)</small>	INITIAL <small>(Of the responsible person(s))</small>
Toolbox Talk	Miscommunication	<p>ANYONE can call ALL STOP at any point if an unsafe condition /act is perceived/observed.</p> <p>Cell phone use is PROHIBITED in test area while testing!</p> <p>Ensure all participants are aware of procedures and roles within the procedure and sign JSEA acknowledging thusly.</p> <p>Ensure that all participants are wearing correct PPE (safety glasses, safety shoes, gloves, and hard hats if crane ops are being performed)</p> <p>Ensure participants/witnesses are wearing adequate clothing for weather conditions and to take breaks whenever necessary.</p>		
Hydraulic Function Testing	<p>Stored/Trapped Energy: Up to 12,000 PSI</p> <p>Environmental Discharge</p> <p>Tubing/Hose Failure</p> <p>Line of Fire</p>	<p>Ensure all functions have pressure/flow reduced to 0 PSI when not being actively function tested.</p> <p>Ensure each circuit is setup correctly before increasing pressure.</p> <p>Ensure Vent hoses are properly connected to fluid containment reservoir.</p> <p>Ensure all hoses are whip checked before coming up on pressure.</p> <p>Ensure valves and actuators are in proper configuration before testing.</p> <p>Ensure relief valves are set to relieve at the proper setting.</p>		

Example JSA task items courtesy of Oceaneering International

NOTE for 2022!!!

Companies should focus their JSA on their deck/dive operations only. **Shop safety and tool safety for building the ROV is extremely important but does not belong in this JSA.** The submitted JSA should

focus information on potential hazards and recommended risk control measures of a company's pool side operations. This JSA should cover topics such as:

Deck Ops/Launch and Recovery:

- Entering/exiting the pool deck area
- System set up
- Power up checks
- Pool side operations
- System breakdown

2.2 Safety Pre-Inspection

A safety pre-inspection will be completed before competition day. Companies will submit the following documentation to the MATE ROV Competition. EXPLORER teams attending regionals should submit their required documentation to their regional coordinator. Regionals may not require all of these documents. Contact [your regional coordinator or visit your regional contest's website](#) to determine the required documents as well as the date and proper format for submission. Safety pre-inspection document submissions will include the following:

- Technical documentation
- Company spec sheet
- SID [Electrical, Pneumatic & Hydraulic as utilized]
- Non-ROV device design document
- Non-ROV device SIDs
- Company safety review

See 2.2.1 Safety documentation requirements below for more information.

Once received, safety inspectors will conduct an **initial safety and documentation review** to identify potential safety violations. This review will be worth 20 points. Companies with violations will be notified via e-mail. Once notified, companies must:

- a. Respond acknowledging receipt.
- b. Layout a plan to address the violation.
- c. Submit new documentation if required.

Safety inspectors will also compile a list of the safety violations and publish them to the competition website. This is not done to "call out" or embarrass companies in any way. It is to emphasize the fact that EVERYONE is responsible and accountable for ensuring a safe, successful event. It also allows the company to correct the safety violations before arriving at the World Championship.

2.2.1 Safety documentation requirements

Unless stated otherwise, each document **MUST** be submitted separately. In addition to the SID included in the technical documentation, an individual SID must be submitted for the initial safety inspection. The company safety review should **NOT** refer to systems shown in a submission video or detailed in the technical documentation.

DOC-001: SID Electrical: This must be an electrical diagram for all ROV systems. One section should focus on the systems above the waterline, and one section should focus on systems on the ROV (below the waterline). The SID:

- Should not exceed one 8.5" x 11" page in length (both above and below water sections, as well as any other information, should be on one page). Printed documents must be sized to fit on one side of the printed paper.
- Must be drawn with a CAD (computer assisted drawing) program. Hand drawn figures are not permitted.
- All symbols used should be standard symbols as specified by ANSI, NEMA or IEC.
- The SID must include a FUSE SYMBOL using an ANSI, NEMA or IEC symbol.
- The SID must not be component level schematics, but a higher-level interconnection block type diagram. Do not include individual pins on a board; the SID is a higher-level diagram.
- Fuse calculations must be included on the SID.

The following ANSI and IEC fuse symbols are all acceptable for MATE documentation.

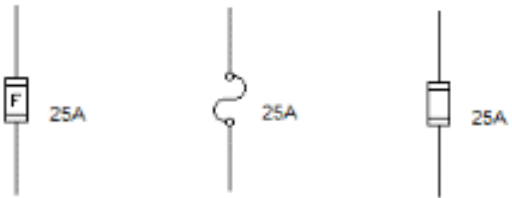
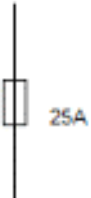
Item	ANSI	IEC
FUSE		

An example of an acceptable SID can be found here:

- EXPLORER example: [2018 Eastern Edge SID](#)

DOC-002: SID Fluid Power: Companies using fluid power **MUST** include a fluid power diagram using industry standard symbols, showing all items, regulators, and control valves. The diagram must document the components on the surface and the components located onboard the ROV. Fluid power diagrams must use ANSI, NEMA or IEC symbols. The fluid power diagram must also be drawn with a CAD program and should be a one 8.5" x 11" page diagram. The fluid power diagram may be included on the main electrical SID or as a separate one-page document.

DOC-003: SID Non-ROV Device: Companies utilizing an independent sensor or other electrically powered, non-ROV device to complete a product demonstration task must submit a SID for this device.

The *MATE Floats!* vertical profiling float, if designed and used at the competition, is considered a non-ROV device. This diagram must be completed to the specifications listed in DOC-001. The non-ROV device SID may be included on the main electrical SID or as a separate one 8.5" x 11" page document. Companies must include fuse calculations on their non-ROV device SID. Companies not designing and building a vertical profiling float should state so in their Company Safety Review.

DOC-004: Non-ROV device design: Companies will be required to submit a one page written and photographic description of their non-ROV device. This document must contain a photo or diagram of your non-ROV device. This document **MUST** include the type of battery used.

NOTE for 2022!!!

Any electrical or fluid powered device on the ROV **MUST** be documented on a SID. Depending on the type of device, it may be on the main ROV SID, an independent sensor SID, a Non-ROV device SID, or a Fluid SID. Any such device not represented on a SID cannot be used in the competition.

DOC-005: Company safety review: EXPLORER companies submitting a company safety review **MUST** show compliance with the following specifications:

- SBS50 Anderson Powerpole connectors are the main point of connection to the MATE supply (ELEC-010E).
- A properly sized Littelfuse is within 30 cm of the main point of connection. The company must use a ruler to show this distance (ELEC-001E).
- Fuse calculations (ELEC-008E).
- The inside of the control box does not have exposed wiring (ELEC-017E), the control box is neatly laid out with attention to workmanship (ELEC-022E), a separation and identification of 120VAC wiring from DC and control voltages (ELEC-023E). If AC wiring is not used in the control box, include a statement saying no AC is used.
- The tether leading to the control system has adequate strain relief (ELEC-024E).
- The tether leading to the ROV has proper strain relief (ELEC-024E).
- If hydraulics / pneumatics are used that the company has passed the Fluid Power Quiz (FLUID-014). **If fluid power is not used on the vehicle, include a statement saying no fluid power is used.**
- If used, hydraulic / pneumatic systems include a pressure release valve and regulator in the system (FLUID-007, FLUID-011), and that any pressurized cylinder, pressure storage device meets the MATE specifications (FLUID-012, FLUID-013).
- Any watertight housing on the vehicle can withstand pressure at 5 meters (MECH-001).
- All propellers are shrouded and have propeller guards (MECH-006).
- The ROV has no sharp edges or elements of the ROV that could cause damage (MECH-006, ELEC-017E).

The following photographs **MUST** be included within the company safety review:

- Anderson Powerpole connector within 30 cm of Littelfuse (show fuse, ruler and connectors)

- Inside of the control box with wires labeled
- Strain relief where the tether connects to the control system
- Strain relief where the tether connects to ROV
- Compressor or pump (if pneumatics/hydraulics are used) including release valve and regulator
- Propeller shrouds (front and back of one propeller)

The company safety review should include an explanation of how each system meets the safety specifications and include photographs of the relevant systems for review by the MATE ROV Competition officials.

Initial Safety and Documentation Review points

Penalty points will be deducted from the initial safety and documentation review if:

- Companies do NOT submit ALL the required documentation by the given date. See 6.2 KEY DEADLINES .
- The SID does not show a fuse, or the fuse does not use an ANSI, NEMA or IEC symbol.
- Fuse calculations are not shown on the SID.
- The vehicle uses fluid power, but a fluid power diagram is not included.
- A non-ROV device is used but is not shown on any SID.
- Companies not using fluid power, or not attempting a task requiring a non-ROV device, do not state this fact in the company safety review.
- The technical documentation is over 8MB in size.
- Other documents are over 2MB in size.
- The company safety review does not show compliance with all of the specifications.

The initial safety and documentation review rubric can be found [here](#).

2.3 Onsite Safety Inspection

Companies must complete their onsite safety inspection before their vehicle enters the water.

Companies advancing to the World Championship must complete their initial on-site safety inspection immediately after checking in. A sign-up form with specific dates and time frames will be circulated in advance of the World Championship. Companies should review this form carefully and select the date and time frame that aligns with their travel plans. Companies that ship their ROV should also consider the expected delivery date and time when making their selection; without a vehicle present, the company will fail their initial safety inspection. Accommodations will be made for companies that experience travel delays beyond their control (i.e., a cancelled flight or flight delay), but these will be the exceptions and not the norm.

Companies are required to check in and undergo their first safety inspection prior to the opening ceremonies.

At the World Championship, companies MUST pass their safety inspection by the end of the first day of the competition. Companies that do not pass their safety inspection by the end of the first day will be disqualified from the underwater product demonstration component.

NOTE for 2022!!! A power supply will be available; companies will power up their control system and vehicle during the safety inspection. The inspector(s) will reference the list of violations as he/she conducts the safety inspection of the vehicle using the safety inspection rubric.

What follows is the safety inspection protocol used at the World Championship. For EXPLORER class teams attending a regional, consult [your regional coordinator or visit your regional contest's website](#) for more information about the safety inspection process used at your regional.

2.4 Safety inspection protocol

1. Before entering the water for practice or a product demonstration run, the ROV system must go through a safety inspection. Once a company successfully passes inspection, they will turn in their safety inspection sheet to the safety inspector and receive a Blue PASSED Card with their company number on it. Companies must present the Blue PASSED Card to the pool practice/product demonstration coordinator before their vehicles are permitted to enter the water.
2. Competition staff will conduct a safety inspection of the vehicle using the [safety inspection rubric](#).
3. If the safety inspector(s) identify a safety violation, companies will have the opportunity to address it. The pool practice or product demonstration run schedule will NOT change to allow companies more time.
4. If during the second safety review the
 - a. violation has not been properly addressed or
 - b. another violation is revealedcompanies will have ONE additional opportunity to address the issue.
5. If during the third safety inspection a violation still exists, safety inspectors will request that the Chief Judge(s) review the violation. If the Chief Judge(s) confirms the violation, companies will not be permitted to participate in the underwater product demonstration component of the competition. However, companies can still participate in the engineering and communication (technical documentation, engineering presentation, and marketing display) component.
6. Reminder: All companies must present the Blue PASSED Card to the pool practice or product demonstration judge before placing their vehicles in the water. In addition, product demonstration station judges and competition officials can pause or stop a product demonstration run at any time if they feel that there is a potential safety concern.

REMINDER!!! Companies do not need to present their Blue PASSED Card to the judges during their engineering presentation. Companies that have their engineering presentations scheduled for the first day do not require an early safety inspection in order to participant in their presentation.

NOTE for 2022!!!

All items used on the ROV MUST participate in and pass safety inspection. Companies that use a device that did not participate in and pass the safety inspection will be disqualified.

2.5 Safety Inspection Points

The safety inspection is worth 30 points. Each time a company fails its safety inspection it loses 10 points. After a company fails its second inspection, it must meet with the chief safety inspector to discuss a plan of action prior to returning to its workstation. THREE STRIKES and a company

- a. Receives 0 points for the safety inspections and
- b. Is disqualified from the underwater product demonstration component

3.0 SPECIFICATIONS

The ROV system (or “system”) must meet the following requirements:

3.1 Operational

3.1.1 Multiple Vehicles

OPER-001: EXPLORER class companies are required to design and build ONE ROV that can complete the necessary product demonstration tasks. “Floating eyeballs” or other vehicles that are not hard connected to the frame of the main vehicle are NOT permitted. Cameras designed to provide a “birds-eye view” are permitted provided that these cameras are hard connected to the frame of the main vehicle. “Hard connection” does not include the wiring between the camera and the ROV.

3.1.2 Environmental

OPER-002: The ROV system must be able to function in fresh, chlorinated water with temperatures between 15°C and 30°C. The water should be considered conductive of electrical currents.

OPER-003: The pool will not be covered or purposefully darkened in any way, although the specific product demonstration tasks may require that your ROV operates in low-light.

OPER-004: Depending on the venue, pressurized pool filtration system outlets may cause unexpected currents.

OPER-005: The pool venue at the World Championship has a smooth bottom.

Note: EXPLORER companies attending regional competitions should note that regionals may be held in pool venues with different environmental conditions than those listed here. If you are unfamiliar with the regional pool, contact [the regional coordinator or visit your regional contest’s website](#) for additional information.

3.1.3 Service Requirement

OPER-006: Companies shall provide a crew of at least 3 but not more than 6 people on the pool deck to operate the ROV System. Companies can send a larger crew complement, but no more than six can be on the deck at any time. More information about this “product demonstration team” is provided in the [COMPETITION RULES](#).

3.1.4 Maintenance and Calibration Requirement

OPER-007: All measurement devices shall be calibrated according to manufacturer recommended calibration procedure and performed by company members only. Company mentors or advisors are not permitted to perform calibration procedures. More information about mentor restrictions is provided in the [COMPETITION RULES](#).

OPER-008: System maintenance during field operations shall be conducted by ROV personnel at their workstations. Work of any kind must not be done by company mentors or advisors. All maintenance parts and equipment necessary to meet the operation requirements shall be provided by the company. More information about these regulations is provided in the [COMPETITION RULES](#).

3.2 Mechanical/Physical

This section of the document provides specifications for the mechanical properties of the ROV system.

3.2.1 Materials

MECH-001: At the World Championship, any electronics housings on the ROV shall be capable of operating to depths of 7 meters.

3.2.2 Size and weight

MECH-002: ROVs are limited to a maximum weight, in air, of 35 kg. Vehicles over this weight will not be allowed to compete. Product demonstration tasks will limit the size of the vehicle. Companies must be able to personally transport the vehicle and associated equipment to the product demonstration station and to the engineering presentation room. ROV systems must be capable of being safely hand launched. Additional points will be given to lighter vehicles (see WEIGHT RESTRICTIONS).

3.2.3 Tether Length

NOTE for 2022!!!

MECH-003E: At the World Championship, ROVs must be capable of operating in a maximum pool depth of 6 meters (19 feet). All underwater product demonstrations will take place within 10 meters from the side of the pool. The product demonstration station will be no more than 3 meters from the side of the pool. Tether length should be calculated accordingly. EXPLORER companies attending regional competitions should note that regionals may be held in pool venues with different maximum depths than those listed here. If you are unfamiliar with the regional pool, contact [your regional coordinator or visit your regional contest’s website](#).

3.2.4 Vehicle Deployment and Recovery

MECH-004: The ROV system must be launched and recovered manually; no powered winches or portable cranes can be used. Hand-powered lifts and levers may be used to launch and recover the vehicle. The vehicle and any associated equipment must not damage any part of the pool or pool deck.

MECH-005: Any hand-powered lift or levers that are used as a LARS must be detailed in the technical documentation and must be part of the safety inspection procedure. Any LARS equipment that is deemed as unsafe at the safety inspection will not be allowed. Ladders, tripods, or other bracing equipment are not permitted as part of a LARS.

3.2.5 Propellers

MECH-006: Propellers must be shrouded and have thruster guards. ROVs that have propellers exposed without thruster guards will not pass the safety inspection and will not be allowed to compete. A shroud must completely encircle the propeller and extend at least 2 mm in front of and behind the propeller. Thruster guards must completely cover any openings on the thruster and should have a mesh size that meets [IP-20 standards](#) (solid particulate protection level 2). This IP code equates to a mesh size >12.5 mm. To pass safety inspection, the shroud and propeller guard should meet this standard. If your finger can touch the propeller, then it is not properly guarded.

Teams may construct thruster guards, 3D print thruster guards, or may purchase commercially available thruster guards. All motors on the ROV must be protected with shrouds and thruster guards on all sides.

See <https://www.thingiverse.com/thing:1498338> for an example of an acceptable thruster guard.

3.3 Electrical

ELEC-001: All power provided to the ROV system through an external connection for any purpose during the competition must be obtained from the MATE competition power supply. This includes dedicated lines for cameras, manipulators, and any other devices. This is a singular point of connection; all power to the ROV must pass through the MATE-provided fuse AND the single in-line fuse as specified in this section.

NOTE for 2022!!!

Companies **MUST** use one of the following inline fuse(s) that are rated for the voltages used on EXPLORER class ROVs. Circuit breakers will not be allowed on the ROV system.

[30-amp fuse](#)

[25-amp fuse](#)

[20-amp fuse](#)

[Fuse holder](#)

Companies may also purchase fuses and fuse holders from the [SeaMATE store](#).

ELEC-002E: The ROV system must be capable of operating off the power provided by a MATE supply with a nominal voltage of 48 VDC. Power supplies will be a fixed output voltage and will not be “turned down” to accommodate other than the specified voltage for the class. All references to 48 VDC in this document are the nominal voltage of 48 VDC.

ELEC-003E: The ROV system must deliver the supply voltage to the ROV as provided and without modification. No conversion of this voltage is allowed prior to it arriving at the ROV system bus. Methods on the surface such as DC/DC converters, voltage drop resistors, and Pulse Width Modulation (PWM) are not allowed to be used between the ROV and the power source. ESCs and H-bridges are not allowed on the surface. Power supplies and conversion devices are not allowed on the surface if they operate the ROV.

MATE strongly urges companies to refrain from sending reduced voltage signals from the ROV back up the tether to power devices on the surface. This is not done by ROVs in industry and therefore discouraged by the MATE ROV Competition.

ELEC-004E: ROV systems may use any voltage desired up to 48 Volts, but any conversion to a lower voltage must be made on board the ROV. Companies will not be permitted to operate an ROV that reduces the voltage on the shore-side/top-side end of the ROV tether.

ELEC-005E: Voltage may not be increased above the nominal 48 volts anywhere in the ROV system.

ELEC-006E: Sonar or other systems that may have DC/DC conversion resulting in voltages above 48V nominal are not permitted.

ELEC-007E: Voltages in excess of the class parameters set forth in this specification are not allowed on the ROV system at any time other than any inductive spikes that are caused by the switching on/off of motors, solenoids and other inductive devices. Companies should design their systems to handle these voltage spikes but will not be penalized for the presence of these in a system. For additional information on this, companies can research back electromotive forces (back EMF), collapsing magnetic motor fields, and transient suppression.

3.3.1 Non-ROV Device Power Specifications

NOTE for 2022!!!

Systems that qualify as a non-ROV device in 2022:

- Vertical profiling float

No other devices qualify as non-ROV devices.

ELEC-NRD-001: The vertical profiling float cannot be powered from the surface. If the float is powered, it must use onboard batteries. Voltage is limited to 12 VDC maximum; amperage is limited to 6 amps maximum.

ELEC-NRD-002: The vertical profiling float non-ROV device may not utilize thrusters nor include any cameras.

ELEC-NRD-003: Companies may not power the vertical profiling float non-ROV device from the surface.

ELEC-NRD-004: Onboard power is allowed for non-ROV devices. If onboard batteries are being used, the following specifications must be met:

- Batteries must be primary (non-rechargeable).
- AAA, AA, A, A23, C, D or 9V alkaline batteries are allowed. No other size or chemical composition is allowed. 12 volt, outdoor, rechargeable batteries are **NOT** allowed. High discharge LiPo batteries are **NOT** allowed.
- Batteries are mounted in a manner that they are not loose inside the container.
- A fuse (7.5 amps max) must be installed within 5 cm of the battery positive terminal.
- The enclosure housing must be designed so that it will open if the pressure inside the housing is greater than the outside pressure.
- Any pressure relief plug **MUST** be at least 2.5 cm in diameter. Smaller plugs will not pass safety inspection.
- The enclosure housing must be designed so that it will release pressure if pressure inside the housing is greater than the outside pressure. Under no condition should the housing be built with fasteners to hold the device together if there is no pressure release valve. At least one opening must serve as a pressure release. This can be achieved by:
 - The battery holder must be mounted in a manner that will allow the end cap to freely open if pressure develops inside the housing.
 - Battery containers utilize a pressure release valve AND a Schrader valve. The pressure release valve must be rated no more than 3 psi.

Companies using a pressure release valve for their onboard battery container provide specifications and factory cut sheets of the valve used to the [Competition Technical Manager](#) no later than May 15th, 2022 for review by the MATE safety committee.

Examples of acceptable methods for housing batteries include:

- A PVC pipe with wires penetrating one end and the opposite end plugged with a pressure release plug (rubber stopper, etc.). Note: Any pressure release plug **MUST** be at least 2.5 cm in diameter. Smaller plugs will not pass safety inspection.
- Cylinder with batteries mounted inside. One end of the cylinder sealed with caps and O-rings, but no fastening devices holding the end cap on.
- Cylinder with both a properly rated pressure release valve and a Schrader valve.

ELEC-NRD-005: A SID must be submitted for any non-ROV device that uses electrical power.

3.3.2 Independent Sensors

Certain product demonstration tasks may require a sensor that is independent of the vehicle. These electrically powered sensors will operate under the following independent sensor rules.

ELEC-IS-001: Independent sensors must be powered from the surface; no onboard batteries are allowed.

ELEC-IS-002: Companies may use USB to connect their sensor to a computer. Companies may also use surface battery packs (limited to 12 volts maximum) or the MATE supply to provide power for their independent sensor.

ELEC-IS-003: The independent sensor may only contain the intended sensor; thrusters, cameras, or other systems MAY NOT be attached.

ELEC-IS-004: Companies that use an independent sensor must provide a 3 amp (or less) fast blow fuse on the positive side of their connection. If companies are using the 48-volt MATE supply to power their sensor, both the ROV and the sensor must run through the single fuse before splitting off to the 3 amp sensor fuse. Companies using USB only to power an independent sensor may utilize the built-in current limiting of USB and do not need to add an additional fuse.

ELEC-IS-005: A SID must be submitted for an independent sensor that uses electrical power.

3.3.3 Current

ELEC-008E: ROVs will be limited to 30 amps.

The ROV system must have a fuse that is calculated based upon the maximum current draw of the ROV. This overcurrent protection must be calculated as follows: $\text{ROV Overcurrent Protection} = \text{ROV Full Load Current} * 150\%$. The overcurrent protection value may be rounded up to the next standard fuse. The ROV Overcurrent Protection value may exceed 30 amps, but companies are limited to a 30-amp fuse. Companies must use the fuse that is rated for overcurrent protection. Companies that use a fuse larger than their calculated value will not pass safety inspection. Companies may use a fuse smaller than their calculated value without penalty. The fuse must be installed in the positive power supply line within 30 cm of the power supply attachment point. The fuse may be a slow blow type. The SID and other electrical diagrams must show the fuse and include the amperage of the overcurrent protection. In addition, the SID must show the calculations used in determining the overcurrent protection value. SIDs without these calculations shown will have points deducted from the initial safety inspection sheet. Also, SIDs without fuse calculations will not pass safety inspection. The motor current used must be full load current while in water, not while operating in air. Overcurrent calculations using the lower current values will be rejected.

ROV overcurrent protection example 1:

- Eight motors, 2.7 amps each = 21.6 amps
- Two cameras = 0.25 amps

- Two servo motors = 0.8 amps
- One laser = 0.002 amps
- Total Amps: **22.87 amps** X 150% = **33.98 amps**
- ROV uses a **30-amp** fuse

ROV overcurrent protection example 2:

- Four motors, 2.7 amps each = 10.8 amps
- Two cameras = 0.25 amps
- Two servo motors = 0.8 amps
- One laser = 0.02 amps
- Total Amps: **11.87 amps** X 150% = **17.8 amps**
- ROV uses a **20-amp** fuse

All information on overcurrent protection should be included on the SID. Show your work.

The MATE power supply will be protected by a 30-amp fuse; however, the ROV system must also have its own calculated fuse.

ELEC-009E: ROV systems are allowed one replacement fuse during the product demonstration. In the event that the ROV system blows the second fuse during the demonstration, the demonstration will be over and no additional points will be earned. Companies should have adequate replacement fuses on hand, MATE will not provide replacements. Standard sizes for fuses are 15, 20, 25 and 30 amps. Additional standard fuse sizes are 1, 3, 7.5, and 10 amps.

3.3.4 Power Connections

ELEC-010E: Power supply connections will be Anderson Power Connectors. Companies' ROV system power wires must have proper connectors to obtain power. The Anderson Power Connectors must be connected to the ROV power wires securely; use of proper (hydraulic) tooling is required. Hand crimp tools do not have the force necessary to ensure proper and safe connections. MATE will not provide companies with connectors or adapters at the 2022 World Championship.

<https://www.andersonpower.com/shop/blue-sbsr50-standard-housings-up-to-110-amps.html>

Housing: Anderson SBS50BLU-BK

Pins: The proper pin for your tether conductors

12 or 10 AWG: [Anderson 1339G3-BK](#)

8 AWG: [Anderson 1339G5-BK](#)



<http://leeselectronic.com>

MATE strongly discourages the use of Anderson Powerpole “knock-offs.” These connectors do not meet electrical specifications and have the potential to melt under load. Companies unable to locate a source of genuine Anderson Powerpole connectors can purchase Anderson Powerpoles from the SeaMATE Store or should contact their regional coordinator (if an EXPLORER class regional is held in your area).

NOTE for 2022!!!

Companies not able to purchase Anderson Powerpole SBS50 connectors in their area can purchase connectors from the [SeaMATE store](#).

ELEC-011E: The power supply may be located up to 1 meter from the station table and may be located on either side of the table. MATE recommends a power cable long enough to reach the power supply up to 3 meters from your control system.

3.3.5 Tether Voltages

The signals in the tether must meet the following specifications:

ELEC-012E: Low voltage, low current AC or DC control or sensor signals. Low voltage is defined as a voltage equal to or less than the maximum supply voltage per class specification. Low current is defined as being less than 500mA. Examples include video signals, control signals for electrically powered manipulators, sensor signals, etc.

ELEC-013E: DC main-supply at a nominal voltage of 48VDC as provided by the MATE power supply.

ELEC-014E: Ethernet, USB, or other ANSI or IEC accepted serial protocol signals.

NOTE for 2022!!!

All cameras, including USB cameras, must be powered by the MATE supply. Powering a USB camera from the MATE supply can be accomplished by using a USB repeater / extender that has a separate power input at the far (ROV) end. The ROV must convert the 48V to 12V or 5V as needed to power the device

from the MATE 48-volt supply. This conversion must be done on the ROV. USB cameras plugged directly into laptops are not allowed. Be sure to denote camera power on your SID.

ELEC-015E: NTSC or PAL Video signals

ELEC-016E: Fiber optic cabling of any type may be used.

3.3.6 Exposed connections and disposable motors

ELEC-017E: ROVs with electrical connections that are exposed to water and not sealed are not permitted to enter the water. Taping a connection with electrical tape only does not constitute a sealed connection. The process of sealing electrical connections must include methodologies such as, but not limited to, Silicone RTV, hot melt glue, epoxy, self-vulcanizing tape, and enclosure of the connections in a housing.

ELEC-018E: “Disposable motors” are not permitted; these are exposed motors with no waterproofing.

Brushless motors must be properly waterproofed. Companies must show manufacturer documentation showing their brushless motors are waterproof, or companies must properly waterproof their motor and provide documentation showing their methodology. Non-sealed brushless motors will not pass safety inspection.

See the [MATE Technical Bulletin](#) for proper methods to waterproof a brushless motor.

3.4 Onboard Electrical Power

ELEC-019E: Onboard electrical power (i.e., power not provided by the tether): Onboard battery power is not allowed on the primary ROV. See **3.3.1 Non-ROV Device Power Specifications** regarding onboard power.

NOTE: Water leaking into a closed battery container can result in the generation of hydrogen gas. This gas can build up inside a pressure housing and create an unsafe situation. Any battery housing must be designed to open if the pressure inside the housing is greater than the outside pressure to meet the MATE safety standards. See the non-ROV device onboard battery rules (ELEC- NRD-004) for more information.

3.5 Power Shutdown

ELEC-020E: For safety purposes, any ROV system that is disconnected from the surface supply must stop functioning in less than 5 seconds. This applies to electrical, pneumatic, and hydraulic power sources. Any filters, capacitors or accumulators must be sized accordingly to meet this specification.

3.6 Fluid Power

Any vehicle using fluid power must provide a fluid power diagram. Fluid power is defined as hydraulic pumps (water) or pneumatic pumps (air) on the vehicle or on the surface.

3.6.1 Hydraulic Power

FLUID-002: Hydraulic fluid: Water or biodegradable food-grade fluid, only.

FLUID-003: If a biodegradable food-grade fluid is used, a Material Safety Data Sheet (MSDS) must be provided at the safety inspection. The MSDS must show the type of fluid used and its compatibility with the Biodegradable Food-Grade specification. Companies using water do not need to provide an MSDS.

FLUID-003: If a biodegradable food-grade fluid is used, a Material Safety Data Sheet (MSDS) must be provided at the safety inspection. The MSDS must show the type of fluid used and its compatibility with the Biodegradable Food-Grade specification. Companies using water do not need to provide an MSDS.

FLUID-004: The following fluids are approved for use in hydraulic systems:

- a. Water
- b. Biodegradable Food-Grade Hydraulic Oil ISO Grade 32/46, SAE Grade 20, McMaster-Carr part# 3499K22

All other bio-degradable food-grade fluids must be approved by the [Competition Technical Manager](#) by May 15, 2022. Companies with regional competitions prior to May 15, 2022, must have their bio-degradable food-grade fluids approved two weeks prior to their regional event.

FLUID-005: Maximum Hydraulic pressure allowed: 10.33 bars (150 psig).

NOTE for 2022!!!

FLUID-006: Hydraulic system: All lines, fittings, and hydraulic devices must be rated for a minimum pressure of two (2) times the maximum supply pressure.

FLUID-007: Hydraulic pumps must be part of the safety inspection.

1. They must have a pressure relief valve with a maximum setting of 300 psig or less installed before the pressure regulator.
2. The pump must have a regulator in place and set to 150 psig or less.
3. Pumps with any sign of external rust or deterioration will not be accepted.
5. All wiring must be secure.
6. All guards must be in place.
7. Hydraulic pumps may run off of the 15A 115VAC outlet provided for command and control as long as the hydraulic fluid is not used to propel the ROV. The hydraulic fluid is to be used for grippers and actuators only.

3.6.2 Pneumatic Power

FLUID-008: Pneumatic fluid: Compressed air or inert gas only

FLUID-009: Maximum pressure allowed: 2.75 bars (40 psig)

NOTE for 2022!!!

FLUID-010: Pneumatic system: All lines, fittings, and pneumatic devices must be rated for a minimum pressure of two and a half (2.5) times the maximum supply pressure. For example, if an 83 bar (1200 psig) tank is regulated to 2 bars (30 psig), then all system components must have a minimum rating of 5.17 bars (75 psig). **Note: Aquarium tubing is not generally rated for the pressures associated with compressed gas systems and should not be used in a pressurized pneumatic system.**

FLUID-011: Air compressors must be part of the safety inspection.

1. They must have a pressure relief valve installed before the pressure regulator.
2. The compressor must have a regulator in place and set to 40 psig or less.
3. Compressors with any sign of external rust will not be accepted.
4. The tank drain valve must open.
5. If more than 5 ml of water exits upon opening the drain valve, the compressor will not be accepted.
6. All wiring must be secure.
7. All guards must be in place.
8. Air compressors may run off of the 15A 115VAC outlet provided for command and control as long as the air is not used for motor thrust. The air is to be used for buoyancy/ballast, grippers and actuators only.

At the World Championship, the MATE ROV Competition will provide compressed air at each station. Companies using compressed air **MUST** attach to the provided compressed air; companies may not use their own compressor. See **Error! Reference source not found.** for more information.

3.6.3 Pressurized Cylinders

FLUID-012: Pressurized cylinders may be used, but must remain above the water surface and meet the following specifications:

- a. Approved by US DOT (Department of Transportation) or TC (Transport Canada). For regional competitions taking place outside of the US, check with [your regional coordinator](#) for approval.
- b. Have a current official inspection/test sticker and/or stamp.
- c. Stamped with the maximum allowable pressure.
- d. Contain a pressure relief safety device.
- e. May be filled up to the maximum allowable pressure of the cylinder.
- f. Must be regulated at its output to a maximum of 2.75 bar (40 psig).
- g. Must have an easily accessible shut-off valve that is clearly marked with instructions.
- h. May only be stationed on the surface, not on the ROV.

- i. Must be secured in a safe manner such that they will not fall or roll around. If the judges feel that a cylinder is unsafe, they have the discretion to prevent its use.
- j. SCUBA tanks are permitted. They must meet all the above specifications and have a current visual inspection sticker, or “fill permit” visible.

NOTE for 2022!!!

Electronic housings and other enclosures on the ROV must operate at surface pressure. Companies may not pressurize their electronics housing.

3.6.4 Pressure operated devices (PSO)

MATE will allow the use of soft-walled pressure operated devices in the competition provided they meet the following specifications:

- Device uses a pressure release valve of 7 psi maximum.
- Company provides specifications and factory cut sheets of the valve used and a description of the device to the [Competition Technical Manager](#) no later than May 15th, 2022 for review by MATE safety committee.

The intent of the exception to the pressure specifications is to allow the use of bladder type devices and flexible grippers that operate a few psi above ambient and would be destroyed if tested at full MATE pressure specifications. This exception does not apply to cylinders, pressure vessels or other pressure containment devices. If the device is tested to the 40 psi (pneumatic) or 150 psi (hydraulic) MATE specifications, a pressure release valve is not required.

3.6.5 Unpressurized cylinders

FLUID-013: Companies may fill containers on the ROV with air provided those containers never exceed ambient pressure. Any such container should have at least one ¼-inch (6.35 mm) hole drilled into the bottom of the container to allow excess air to spill out.

3.6.6 Pressure Storage Devices (Pressure Accumulators)

FLUID-014: Pressure storage devices are allowed on the ROV if they do not exceed 1.25L in total storage and do not store pressure higher than the allowed pressure for air or hydraulics. It is recognized that a company may not be able to purchase a pressure accumulator that has the proper rating and fits in the space needed. In that case, the company must show that their designed accumulator is capable of withstanding the specified pressures without rupture.

3.6.7 Chemical Creation of Gases

The chemical creation of gases is not allowed.

3.6.8 Fluid Power Quiz

FLUID-015: EXPLORER class companies planning to use hydraulics and/or pneumatics (i.e., fluid power) are required to take and pass an online quiz with a score of 100%. Companies ONLY using manual pumps and unpressurized containers are not required to take the Fluid Power Quiz, but must still submit documentation regarding their fluid power system.

NOTE: The quiz was developed by MATE ROV Competition technical support staff and competition judges and is designed to ensure that companies understand basic information on these topics and can apply that knowledge to safe practices. The intention is not to add yet another “requirement,” but rather to provide a safe and successful learning experience and competition environment.

The quiz should be completed by the STUDENT company members. Each member of the company does NOT have to take the quiz; students can work together and make it a group effort. **ONLY ONE TEST PER COMPANY.** The company’s instructor or mentor can provide guidance and advice, but the questions should be answered by the students participating on the company. The quiz will be scored and the results provided instantaneously. A score of 100% is considered a passing grade. Companies can take the quiz as many as 5 times to achieve this score.

The quiz must be completed with a passing grade by April 26th, 2022. NO EXCEPTIONS OR EXTENSIONS! Companies will be able to purchase and take the fluid power quiz beginning December 1st. The [fluid power quiz may be purchased here](#). Note that if registration for your regional competition opens after the fluid power closing date, you must still take the quiz before April 26th. Companies failing to complete this quiz within the given time frame will NOT be permitted to use fluid power during their competition event. **NO EXCEPTIONS OR EXTENSIONS! See [6.2 KEY DEADLINES](#).**

FEE TO TAKE THE FLUID POWER QUIZ! The fee to take the fluid power quiz is \$25 for five attempts (no discounts for fewer attempts). Companies will receive immediate access to the fluid power quiz once it is purchased. The link will be included in their receipt.

The following are sources of information on hydraulics and pneumatics. This is not intended to be an exhaustive list, but rather a starting point to encourage companies to seek out additional information and resources.

- Underwater Robotics: Science, Design & Fabrication, published by the MATE Center and MATE Inspiration for Innovation – (see www.marinetech.org/underwater_robotics)
- <https://www.nfpa.com/home/About-NFPA/What-is-Fluid-Power.htm>
- <https://www.quincycompressor.com/tips-for-working-safely-with-compressed-air/>
- Parker Hannifin Corporation – <http://www.parker.com/> (look for technical literature links)

3.7 Control Systems

ELEC-021E: EXPLORER class ROVs are expected to utilize computer- (or electronic-) based control methodologies and H-Bridge or BLDC controllers for the thrusters. Systems using surface switch box controllers are not permitted.

ELEC-022E: Surface control stations must be built in a neat and workmanship like manner. Loose components and unsecured wires will not pass safety inspection.

ELEC-023E: Surface control stations by nature may combine 120VAC and 48VDC wiring. The surface control stations must be wired in a manner such that the 120VAC wiring is physically separated from the DC wiring, the 120VAC wiring is clearly identified from the DC and control voltages, and every conductor is insulated in a manner that no conductor is exposed. Identification can be through signage and/or wire color schemes. All 120VAC wiring colors must use ANSI, NEMA or IEC standard wiring colors appropriate to each voltage. There must be a sign inside the surface control station indicating which wiring standard is being utilized. Companies that do not have adequate separation of AC wires and components and DC wires and components will NOT pass safety inspection. It is recommended that separation be designed into the control system to keep power systems separate. Wiring should be clear, neat and easy to follow by inspectors. Wiring “Rat’s nests” or “spaghetti wiring” will not pass safety inspection.

ELEC-024E: Companies must use proper strain relief and abrasion protection where wires and the tether enter the vehicle. The ROV should be capable of being lifted by the tether without damaging the tether connection to the ROV. Tape, glue, zip ties, and other quick methods of strain relief are not acceptable. The intent is to see the wires pass through a connector specifically designed to provide strain relief.

Companies must use proper strain relief at the surface where wires and the tether enter the control system. Pulling on the tether should not strain the wires entering the control system.

Examples of some acceptable strain reliefs for the ROV side include:

[Hubbell Strain Relief 1](#)

[Hubbell Strain Relief 2](#)

[Strain relief grip](#)

[Kellums strain relief cord grip](#)

ELEC-025E: Any connectors utilized in the surface control station and elsewhere in the ROV system must be properly type rated for their application. AC rated connectors must not be used for DC. The connectors must also be rated at or above the voltage and current used in their application.

3.8 Command, Control, & Communications (C3)

3.8.1 Power Provided

CCC-001: Surface power: MATE will provide one GFI-protected outlet with a nominal 115 Volts AC (60 Hertz) and 15 amps maximum. This outlet is intended to provide power for pumps and other surface support equipment (e.g. video monitors & control boxes). This AC power source CANNOT be used to directly or indirectly power the vehicle.

CCC-002: If hydraulic or pneumatic power is used for vehicle thrust, the power for the pump must come from the MATE supplied DC power supply.

CCC-003: In addition to electric pumps, hydraulic, and pneumatic systems can be powered by manual pumps (e.g. bicycle tire pump) or supplied from a pre-pressurized cylinder. Companies that are only using manual pumps must still comply with all hydraulic and pneumatic specifications, including the creation of a fluid power SID.

3.8.2 Displays

CCC-004E: Companies are not limited to the number of display screens used for video feeds or ROV status information. Display devices may be made up of any combination of TVs, monitors, laptops, and/or computer displays.

CCC-005E: These display devices may be powered by the MATE provided GFI-protected 115-Volt AC (60-cycle) and 15-amp AC power source described in CCC-001, Surface power.

CCC-006E: A company's C3 station may include devices like video recorders. All C3 devices must be able to run on the single AC power outlet provided or on its own internal battery power. Any device plugged into this AC power outlet can only provide C3 functions and cannot provide power to the ROV.

CCC-007E: A company's C3 station should have all items stable or secured to the station. Large monitors not secured to and stable in the product demonstration station are not permitted. Monitors and other C3 devices with glass faceplates are not permitted.

3.9 MATE Provided Equipment

MATE will **NOT** provide video monitors at the product demonstration stations.

In 2022, the MATE ROV Competition will supply compressed air at each station during the World Championship. Companies may connect to this compressed air via a standard ¼-inch NPT male fitting. For companies attending an EXPLORER regional, contact your [regional coordinator or visit your regional contest's website](#) as to whether compressed air will be provided at your regional competition.

3.9.1 Companies Sharing Equipment

Companies may share the following equipment during the competition event: monitors, joysticks, and compressors.

Companies may NOT share the following equipment during the competition event: control systems and payload tools (e.g. grippers, manipulators).

For companies attending an EXPLORER regional, contact [your regional coordinator or visit your regional](#)

[contest's website](#) to determine if equipment can be shared at your regional event.

Companies that plan to share equipment during the World Championship event must notify the [Competition Technical Manager](#) at least 4 weeks prior to the event so that this can be considered when creating the schedule. MATE will do its best to accommodate companies sharing equipment.

3.10 Laser Safety Rules

LASR-001: **Companies must forward the specifications of their laser to the [Competition Technical Manager](#) by May 15th, 2022. Specifications MUST include a link to the laser being used. The link should include a photo of the laser and the laser specifications.** A notification will be sent to the company when the laser is approved. Companies must also bring a copy of their laser specifications to their safety checks. If the laser is being used at a regional event or pool practice, notification will also be sent to the regional competition coordinator.

LASR-002: All lasers must operate in the visible range at either the 630-680 nm (red) or near the 532 nm (green) wavelength. All lasers must fall into the Class I, Class II, or Class IIIa category. Red lasers must operate at 5mW or less. Green lasers must operate at 1 mW or less.

LASR-003: Companies should include detailed specifications of their laser in their technical documentation as well as have that information ready and available during their safety inspection and engineering presentations.

LASR-004: Lasers must have an on/off switch. This switch must be on the surface controller.

LASR-005: All lasers must be powered by the MATE surface power supply. Batteries, including batteries for powering lasers, are not permitted on the vehicle.

LASR-006: Companies using lasers cannot increase the voltage or the current to increase the power of their lasers. Lasers must use the voltage and current set in their specifications.

LASR-007: When out of the water, the laser should have a shield or enclosed beam stop attachment within 30 cm of the laser. This means that the laser beam should not travel more than 30 cm before reaching the shield. This is a requirement at all times when the laser is out of the water. The shield does not need to be attached to the ROV while it is in the water. The shield must be painted with FLAT BLACK paint.

LASR-008: At no time should the laser be focused or deviate from a collimated beam.

LASR-009: When testing the laser at a workstation, companies must display a sign telling others that a laser is being operated.

LASR-010: Operators working with the laser while the ROV is out of the water should wear appropriate laser safety glasses at all times. This requirement is for all laser types. Search online to find laser safety glasses appropriate for the wavelength being used.

Companies must forward the specifications of their laser safety glasses to the [Competition Technical Manager](#) by May 15th, 2022. Specifications MUST include a link to the laser safety glasses being used. The link should include a photo of the laser glasses and the laser glasses specifications. A notification will be sent to the company when the laser safety glasses are approved. Companies must also bring a copy of their laser safety glasses specifications to their safety checks. If more than one brand of glasses are used, a copy of each specification sheet should be provided.

The following lasers are acceptable to use in the MATE ROV Competition, although companies may choose to use alternate lasers. NOTE: **ALL COMPANIES MUST STILL FORWARD SPECIFICATIONS TO THE COMPETITION TECHNICAL MANAGER, EVEN IF ONE OF THE FOLLOWING LASERS IS USED.**

- [Amazon.com: HiLetgo 10pcs 5V 650nm 5mW Red Dot Laser Head Red Laser Diode Laser Tube with Leads Head Outer Diameter 6mm : Industrial & Scientific](#)
- [UMLIFE 5pcs 650nm 5mw Laser Head Laser Tube Adjustable Focus 3~5V Red Laser Tube for Sight Positioning Sighting Telescope \(Cross\) - - Amazon.com](#)

PART 4: COMPETITION RULES

4.1 GENERAL

- All members of the company and their supporters must follow the safety regulations of the ROV competition, pool facility, and event venue.
- All company members and their supporters are expected to conduct themselves in a professional and responsible manner during the competition. Disrespectful behavior towards the judges, officials, pool staff, audience, or other companies will lead to penalty points or disqualification.
- Sabotaging, stealing, or pilfering equipment of other companies will lead to disqualification. Companies found cheating will also be disqualified.
- The MATE ROV competition is, at its core, designed to be an educational and inspirational event for **STUDENTS**. It is designed to challenge them to apply the physics, math, electronics, and engineering skills they are learning in the classroom to solving practical problems from the marine workplace. (See the [MATE Competition Philosophy](#).)

It is expected that all “adults” (non-students; e.g. teachers, mentors, parents) involved in the competition limit their input to educational and inspirational roles. Actual construction of the ROV (particularly in the complex electrical and software areas) must be completed by the students. Adults should teach and advise students about design, electronics, software, and

construction, but not complete the work for the students. Throughout the process adults are encouraged to focus on benefits to the students from the process and not simply winning. If it becomes apparent that adults exercised more than an advisory role, judges reserve the right to deduct points or, in extreme cases, disqualify companies from the competition.

ALL work done on the vehicle must be conducted by company members. This includes any work done at home, at school, or during the MATE ROV competition (World Championship and regional). Teachers, mentors, parents, and non-competing students are not permitted to work on the ROVs. They may provide advisory input, but they may not work on the ROV directly. This includes writing or editing software code. All mechanical, electrical, and software modifications and/or repairs to the ROV must be completed by students.

With learning at its core, the MATE competition encourages students to utilize and build upon their skill sets to find creative solutions to designing and building their ROV. Students gain valuable skills and knowledge when creating a component from “scratch,” which is apparent to judges as they review the technical documentation and engineering presentation. However, as they move through the process of analyzing their designs and identifying building materials, students may decide to either build a component from “scratch” or purchase it from a commercial vendor.*** So, while original solutions are encouraged, the use of commercial components is acceptable, provided 1) that the components adhere to the design and building as well as safety specifications for the particular competition class and 2) more importantly, that the students can provide a reasonable, logical explanation for buying versus building.

The competition scoring rubrics are designed to reflect this; points are awarded based on students’ abilities to explain and justify how all of the components and systems work together as an integrated ROV, regardless if they purchased them, pulled them from public libraries, or made them themselves.

***Note “commercial vendor” includes the [SeaMATE store](#) and other competition programs that sell educational robotics kits. SeaMATE kits were created to remove barriers to participation for teachers and schools unable to easily 1) find parts and materials and 2) set up accounts with multiple vendors. The kits are part of a larger educational package that includes curriculum materials, videos, and other resources to support and enhance learning. And learning is what students who use SeaMATE (or other) kits will be expected to demonstrate during and through the [ENGINEERING & COMMUNICATION](#) components.

It should be noted that purchasing and competing with complete, assembled, commercial ROVs is not permitted.

4.2 PROCEDURAL

- Companies must compete during their assigned time slots. Your company is **NOT** permitted to switch time slots with another company. Failure to show for your scheduled product demonstration or for your company’s engineering presentation will result in “no score” for that particular competition category. **No exceptions.** Assigned time slots will be sent out in advance so that any scheduling concerns can be addressed prior to the event.

*Regional contests may refer to the product demonstration station as the control “station” or “shack.”

- Companies must complete their weight measurements before each product demonstration run. The weight measurements are included as part of the product demonstration score. Companies should be at the weigh in area at least 20 minutes before their scheduled product demonstration run.
- While there is no limit to the number of students who can compete as part of a company, **the product demonstration team (aka demo team) is limited to six students.** The demo team is defined as the team of students who operate the vehicle and its associated equipment during the product demonstration. Only six students will be allowed to enter the product demonstration station, launch, pilot, and perform the tasks. Instructors, mentors, and/or non-student members cannot participate as part of the demo team. **Companies may alternate students on the demo team for the two product demonstration attempts.** (All members of the company should participate in the engineering and communication components; see [ENGINEERING & COMMUNICATION](#) for more information.)
- Only the demo team members and judges are allowed at the product demonstration station during the product demonstration, which includes the set-up and demobilization periods. Other members of the company, instructors, mentors, audience members, and observers (press or special invited guests) must remain outside the product demonstration station or in designated viewing areas.
- Instructors, mentors, parents, and “fans” are **NOT** permitted at the safety inspection stations or repair tables. Two warnings will be issued before individuals not heeding this rule will be asked to leave the venue.
- In addition, instructors, mentors, parents, and fans are **NOT** permitted to work on the ROV. Individuals who are seen working on the ROV who are not student company members will be issued a warning. Two warnings will be issued before individuals not heeding this rule will be asked to leave the venue. If companies choose to take their ROVs off the competition grounds for maintenance and repair, they are expected to observe this rule in the interests of the spirit of the competition.

- To help enforce this, teachers, mentors, parents, and non-competing students MAY have limited access to the workstation areas. Contact the [MATE ROV Competition officials](#) for more information.
- Video devices may be used to record the underwater activities for entertainment and learning purposes **only**. Video will not be used as an instant replay to review judges' decisions or to challenge product demonstration timing.
- Product demonstration stations will be roped off and marked. Product demonstration stations will contain 2-3 chairs and one 6-foot table long table for companies to use. This table will be within 3 meters of the pool edge. Product demonstration stations will be set up to prevent the pilot(s) from looking at the ROV in or under the water except through the ROV cameras.
- Companies will compete in one product demonstration that will consist of three tasks. Companies will get TWO attempts at the one product demonstration. The higher of the two scores will be added to the engineering and communication score to determine the total, overall score for the competition.
- The product demonstration time consists of a 5-minute set-up period, a 15-minute performance period, and a 5-minute demobilization period. If the demo team and all of their equipment are not out of the product demonstration station at the end of the 5-minute demobilization period, the company will be **penalized 1 point for each additional minute**.

Note: Regional competitions *may not* offer two attempts at the product demonstration. Regional competitions may allow more or less time to complete the product demonstration. EXPLORER class companies participating in a regional competition should contact their [regional coordinator or visit their regional contest's website](#) for more information.

- Manipulating the tether to free it from underwater obstacles is permitted. Pulling on the tether to speed up the recovery of items or to return your vehicle more quickly to the surface is not permitted and will result in penalty points. Judges will issue one warning if tether pulling occurs. Each future infraction will result in 5 points deducted from the final product demonstration score.
- SCUBA diver assistance will be available at the World Championship. If help is required, the company CEO or pilot must ask a station judge and divers for assistance. Each diver assist will incur a 5-point penalty. The product demonstration clock will not stop if a company is receiving diver assistance.

Diver assistance may not be available at your regional competition. EXPLORER class companies participating in a regional competition should contact their [regional coordinator or visit their regional contest's website](#) to determine if diver assistance will be available at your regional

competition.

- Pilots can only leave the product demonstration station and move poolside to repair, adjust, or alter a vehicle if the ROV is surfaced and at the side of the pool.
- Companies are not permitted to leave debris in the pool. Any debris must be recovered by the ROV before time has expired or the company will be penalized. Debris is defined as pieces of the ROVs, weights, floats, or other items created by the company. Task props are also not considered debris. The product demonstration notes section may cover special items that can be left in the pool after time has expired.
- No demo team member shall enter the water to complete an object recovery. Only arms and hands are allowed into the pool to retrieve an object or to retrieve the vehicle. Companies will be disqualified or penalized depending on the severity of the infraction.
- Communication between demo team members at the pool edge and demo team members piloting the vehicle will be limited. Only tether management issues (e.g. how much tether is out, how much is remaining on the pool deck) can be discussed. Those team members at the pool edge cannot give any directional or product demonstration task information to the pilot. Judges will issue one warning regarding illegal communication. Each future infraction will result in 5 points deducted from the final product demonstration score.
- Communication using cell phones, text messaging, and online social media tools such as Zoom, Skype, Facebook, Twitter, instant messaging, etc. is NOT permitted during the product demonstration, either between the demo team members at poolside or between any demo team member and anyone outside of the product demonstration station. The ROV and/or the ROV control system is not allowed to broadcast video or other information to anyone outside of the product demonstration area. No exceptions. Companies found broadcasting any data to those outside of the product demonstration area will be disqualified.
- **Product demonstration judges and other competition officials will only communicate with students.** Judges and officials will NOT communicate with mentors, parents, or other non-student members regarding product demonstration information, challenges, or other issues except during pre- and post-competition briefing sessions.

Companies that wish to issue a challenge during the product demonstration run should immediately communicate this challenge to the product demonstration judges. The judges will discuss and attempt to resolve the issue. If a decision cannot be made, the product demonstration judges will consult with the head judges and competition technical manager to resolve the issue.

- **NOTE for 2022!!!**
Once a chief judge rules on a challenge, that ruling is final. NO EXCEPTIONS, including appeals to

other competition officials. Penalty points may be given if companies continue to pursue the challenge beyond the chief judge's final ruling.

4.3 DESIGN & SAFETY CONSIDERATIONS

- The competition coordinators and host venues stress the importance of safety practices and procedures to all companies. The score sheets and rubrics will reflect the MATE ROV Competition's efforts to encourage and reward companies that demonstrate exceptional safety practices and procedures.
- **ALL ROVS MUST PASS A SAFETY INSPECTION CONDUCTED BY COMPETITION OFFICIALS PRIOR TO ENTERING THE POOL.** These inspections will be conducted topside to ensure that ROV systems meet the design and building specifications and do not pose a risk to the integrity of the event venue. See [VEHICLE DESIGN & BUILDING SPECIFICATIONS](#) for additional information.
- Radio transmitters that operate on a separate battery are permitted. No batteries are permitted to be in or on the water. No exceptions.

Companies should be aware of all the implications of these wireless devices. There is no assurance that an adjacent company's wireless controller will not interfere with your control systems. Adjacent wireless controllers with a battery that has a higher charge than the nearby controller have demonstrated the ability to "hijack" the nearby control signals. In addition, all wireless controllers are susceptible to external sources of electronic interference. Your system may work fine in your home environment, but not in the industrial environment of the competition. MATE will not stop the clock to resolve wireless control issues. Companies deciding to utilize wireless controllers do so at their own risk.

- Keep an eye out for tripping hazards in the product demonstration station and at your company's workstation. Make sure power cords are not laying in pools of water on the deck.
- During your product demonstration, be sure to secure any equipment so that it does not fall off the product demonstration station table, damage the deck, or cause injury.
- Loose fitting clothing, jewelry, and long hair could all become safety issues. Consider securing long shirts or baggy pants, removing jewelry, and tying back long hair when working on or operating your ROV.
- ROVs may be constructed out of materials of your company's choice, provided they meet the design and building specifications and safety regulations. Warning labels should be posted on potentially hazardous components of your ROV system.

- Close toed shoes are required on the pool deck. Safety glasses are required when working on the vehicle.
- Personal flotation devices (PFDs) will not be required at the World Championship. No personal flotation devices will be provided by MATE or the host venue. Regional events may require PFDs. EXPLORER class companies participating in a regional competition should contact their [regional coordinator](#) or [visit their regional contest's website](#) to determine if PFDs will be necessary.

PART 5: ENGINEERING & COMMUNICATION

NOTE for 2022!!!

MATE has created an ROV Competition [Marketing Kit](#) that includes logos and guidelines for their use.

The ability to communicate information about your vehicle and the design and building process is equally as important as how well your vehicle performs. Strong communication skills are an essential part of good business practices and one of the most in-demand skills in the constantly evolving, ever-changing workplace.

To emphasize this point, the competition requires the following four engineering and communication components:

- Company spec sheet
- Technical (written) documentation (Examples of spec sheets and technical documentation from previous competitions can be found at <http://www.materovcompetition.org/archiveshome>.)
- Engineering (oral) presentation (Examples of engineering presentations can be found on [MATE's Vimeo channel](#).)
- Marketing display

NOTE: EXPLORER class regional contests may not require all of the Engineering & Communication components. Contact [your regional coordinator](#) or [visit your regional contest's website](#) for more information.

See the [TIPS FOR EFFECTIVE WRITTEN AND ORAL COMMUNICATION](#) for additional information.

NOTE for 2022!!!

Your company should refer directly to the scoring rubrics posted under [Scoring](#) for details on what is required for your technical documentation, engineering presentation, and marketing display. The judges will use the rubrics to evaluate and score these engineering and communication components.

5.1 COMPANY SPEC SHEET

The purpose of the company spec sheet is to provide the judges with a “snapshot” of your company. It includes basic information about your company and vehicle.

Company spec sheets will be reviewed by MATE competition coordinators. Companies will receive up to 20 points for submitting a spec sheet that is **one page** in length, follows the file size and naming specifications, and contains **all** of the following information:

COMPANY SPECS

- **Company and school, club, or community organization name**
- **Home state and/or country**
- **Distance required to travel to the World Championship**
- **History of MATE ROV competition participation.** Be sure to specify if your company and/or the members of your company are “new” or “returning.”
- **Company photo and caption indicating members’ names and roles (e.g. CEO, CFO, Design Engineer, Pilot, etc.).** This photo should include all of the members of your company.
- **Range of grade/college levels represented by the members of your company**

ROV SPECS

- **ROV name** if applicable
- **Total cost.** You must include the approximate cost of any donated items.
- **Size and weight measurements**
- **Total student-hours to design and build.** This should include the number of hours that each and every member of the company worked on the vehicle.
- **Safety features**
- **Special features**
- **Photo of the vehicle**

REMINDER!!! If all of the above information is included, the specifications for length, size, and naming conventions are followed carefully, and the document is submitted on time, this is an “easy” 20 points! You can find the company spec sheet scoring rubric posted [here](#).

5.2 TECHNICAL DOCUMENTATION

The purpose of the technical documentation is to challenge you to effectively and efficiently communicate information using clear and concise text along with graphics, illustrations, and data that add to and complement (and not distract from) the information. Your company must organize and present the information in a way that is logical and complete. The document should focus on the technical and safety aspects of your ROV/ROV systems, the design rationale behind your engineering decisions, and a critical analysis of testing and troubleshooting done on the vehicle. You should consider this document a reference for both judges and future team members (part of the company’s institutional knowledge).

Your company's technical documentation will be reviewed and evaluated by a panel of working professionals – individuals who represent science, exploration, government, and industry. (Don't assume that these same individuals will evaluate your company's engineering presentation!)

Each judge on the panel will award a score (100 points max). Judges' scores and comments will be returned to you shortly after the event.

NOTE: The judges will not review and rescore revised versions of your technical documentation during the competition.

Use the technical documentation scoring rubric posted [here](#) as the guideline for the required components for the technical documentation. This rubric will be posted by March 1, 2022. In the meantime, companies may refer to the previous year's rubrics posted [here](#) for a general idea of the categories and points.

5.3 ENGINEERING PRESENTATION

The purpose of the engineering presentation is to challenge you to effectively and efficiently communicate information with words and "props" (i.e., the ROV). Your company must organize and present the information in a way that is logical and covers the development and testing of your ROVs and the formation and development of your team. The presentation should be delivered as a "technical brief," with references to the technical documentation for additional details (companies should present judges with ONE copy of their document at the start of the presentation). The presentation is THE opportunity your company has to 1) communicate directly and in person your critical thinking, creativity, and engineering reasoning (including build vs. buy) and 2) demonstrate your individual and collaborative contributions to the creation of the vehicle.

During the competition, your company will have 15 minutes to deliver your presentation to a panel of working professionals – individuals who represent science, exploration, government, and industry. (Don't assume that these same individuals will evaluate your company's technical documentation!) After the presentation, the judges will take 10-15 minutes to ask the members of your company questions about your ROV. The judges will evaluate both your presentation and responses to their questions. Each judge on the panel will award a score (100 points max). Judges' scores and comments will be returned to you shortly after the event.

All student members of your company must be prepared to participate in this presentation and the question and answer (Q&A) period. You are required to have your ROV with you. For larger companies, the main presentation may be done by a subset of the overall company. During the Q&A, all members of the company should be prepared to answer. However, if one student is better suited to answer a specific question, the others may defer the question to that student to answer. For example, if a judge calls on the pilot to answer a question about the tether, the pilot can respond by informing the

judge that the tether manager was the lead on that system and allow the tether manager to answer without penalty or loss of points.

NOTE: The engineering presentation is designed to be a face-to-face interaction where students and representatives from industry become engaged in conversation. MATE will not provide audio visual aids, such as slide projectors, computer projection screens, white boards, etc.; however, you are welcome to distribute handouts to help judges better understand the information that you are presenting. Electronic forms of presentation (e.g. PowerPoint or Keynote slides) **are NOT permitted**.

Instructors, mentors, family members, friends, and members of other companies are permitted to attend. However, we ask that those in attendance be respectful and courteous throughout the presentation and follow-up question and answer period. Be mindful that this presentation may be a stressful time for the students. If the room becomes crowded or the spectators become distracting, it is up to the judges' discretion to request that some or all spectators leave the presentation. **While they are permitted to attend, instructors and mentors are not allowed to participate.**

Use the engineering presentation scoring rubric posted [here](#) as the guideline for the required components for the engineering presentation. This rubric will be posted by March 1, 2022. In the meantime, companies may refer to the previous year's rubrics posted [here](#) for a general idea of the categories and points. Judges may ask questions regarding any of these topics not covered in the presentation as well as other questions about the vehicle, the mission theme, or the company.

Preparing for your engineering presentation and Q&A

- Make sure that every member of your company has a good, general working knowledge of your vehicle, even though they may have specialized in one specific aspect of its design and construction.
- Make sure that all the members of your company are familiar with your technical documentation. Ask every member to read it over to catch any errors or omissions. This exercise will help to familiarize everyone with all aspects of the project.
- Generally, you will have more to say about your ROV than can be presented in 15 minutes. That is why it is critical to organize your material and practice communicating it. However, avoid coming across as having memorized your presentation verbatim. Judges want to see that you are prepared and understand the information, not that you can simply regurgitate a rehearsed speech from memory. Ask your instructors or mentors to give you feedback.

Other important items

- If during the engineering presentation it becomes apparent that instructors, mentors, and other adults associated with your company exercised more than an advisory role, judges reserve the right to deduct points or, in extreme cases, disqualify companies.

5.4 MARKETING DISPLAY

The purpose of the marketing display is to challenge you to present technical information in a way that appeals to and is understood by a non-technical audience. It is the promotional piece – you must not only present information about your ROV and your company, but you must also use graphics and design to publicize and “sell” (convince viewers of their value and excellence) your products and people.

During the competition, your company’s display will be evaluated and scored by a completely different group of working professionals – individuals who will represent science, business, government, industry, and education/outreach.

While some judges will have a technical background, others will have a communications, marketing, or public relations background. In addition, there will be visitors to the competition who may not completely understand what an ROV is or how it is used. Think of these visitors as potential future clients who may authorize funding for your work, but have a limited understanding of the technology (i.e., you need to explain your technology, the tasks at hand, and “sell” them on YOUR products and services). Design your display to communicate to this type of audience.

Each judge will award a score (50 points max). Judges’ scores and comments will be returned to you shortly after the event.

WORLD CHAMPIONSHIP COMPETITION ONLY!

NOTE: The MATE ROV Competition will NOT supply display boards.

You must provide your own display board. The space that the text and photographs/graphics occupy CANNOT exceed 36” tall by 48” wide. For example, company names CANNOT be mounted above the display board. NO EXCEPTIONS!

At the World Championship, either easels or tables will be provided for the displays. EXPLORER class companies participating in a regional competition should contact their [regional coordinator or visit their regional contest’s website](#) to see if tables (easels or other) will be provided at your regional event. Companies should create their marketing displays so that they can be exhibited on either a table or an easel.

MATE will continue to provide scissors, tape, glue sticks, adhesives, and other means of attaching display items to the presentation board, although you are also welcome to bring your own.

Use the marketing display scoring rubric posted [here](#) as the guideline for the required components for the marketing display. This rubric will be posted by March 1, 2022. In the meantime, companies may refer to the previous year’s rubrics posted [here](#) for a general idea of the categories and points.

Creating an effective marketing display:

- Address the theme and make real-world connections.
- Reflect your company's personality and mindset.
- Make key points and be concise.
- Keep the general public in mind.
- Make sure to label any and all figures, graphs, diagrams, and photographs and credit the source.
- Maximize the use of the 36" by 48" display space.
- Make sure that it is both informational and aesthetically pleasing.

Note: "Accessories" such as video footage, PowerPoint slide presentations running on laptop computers, video projections, etc. are permitted but should be used with discretion. Remember that the judges will have a limited amount of time to evaluate your marketing display and may find excessive use of audio or video presentations distracting.

However, if you do make a video of your ROV building or competition experience, please submit information about it to the [MATE ROV Competition officials](#) so that it can be shared via MATE's YouTube and Vimeo channels.

5.5 CORPORATE RESPONSIBILITY

The MATE ROV Competition uses underwater robotics to inspire and encourage students' interest in STEM (science, technology, engineering, and math) education and careers. Recognizing that the students who participate in MATE competitions are powerful ambassadors for the program as well as effective leaders in raising awareness of important issues and bringing about positive change, companies have the opportunity to earn up to 20 points for "corporate responsibility."

Corporate responsibility includes, but is not limited to, the following:

- **Mentoring** consists of, for example, providing guidance to other students in your area who are designing and building an ROV for the competition or a science or other project.
- **Engaging the community** includes demonstrating your ROV and sharing information about your company at festivities and other community-wide events. Presenting to a Rotary Club or your school districts board of directors are other examples.
- **Media outreach** consists of:
 - Developing a list local media contacts
 - Writing a press release about your participation in the MATE ROV competition
 - Distributing it to your media contacts
 - Following up with your media contacts to see if they're interested in your company and its ROV
 - Compiling a summary of results

Here are some [general guidelines](#) for working with the media. They are specific to the World Championship, but can be easily modified for regional events.

- **Raising awareness of environmental, social, and governance (ESG) issues. Just look at this year’s theme and product demonstration tasks for ideas – from installing marine renewable energy to reduce carbon emissions to planting blue carbon to sequestering existing carbon in the atmosphere and oceans**
- Corporate responsibility efforts will be reviewed by competition coordinators and awarded 0 to 20 bonus points, depending on the number and scope of the outreach and awareness activity(s), i.e., the number of other students or members of the community engaged, the number of mentoring sessions, etc.

Make sure to include the following information in your write-up:

- Type of activity (e.g. mentoring, exhibiting at a community event, raising awareness)
- Locations, dates, and the amount of time spent on the activity
- Number of students or community members (if a large event, this can be an approximate) involved
- Description of your actions, outcomes, and other information that helps to demonstrate the quality of your time and efforts
- For media outreach, please submit a copy of your press release, a copy of your media contacts list, and a summary of news articles, TV or radio coverage, etc. that your company received. Include copies of articles and URLs, and list any television or radio coverage. Be sure to include name of outlet, date, and a summary of the coverage.

5.6 VIRTUAL REALITY

Teams advancing and competing in the 2022 MATE World Championship in either the In-Person or the Telepresence category can receive up to 25 points for populating their workstations in VR with the following assets:

- Company logo
- Company name, organization/school name, home state and/or country, and tagline
- 3 photos for the photo wall
- Slideshow of images
- 3D CAD or photo of ROV
- Marketing display “commercial” (video or slideshow)

The following are the 2 options for populating your team workstation.

OPTION 1:

Already feeling underwater just preparing your ROV for the competition? You submit your team’s assets to MATE and our World Builder populates your workstation. If your team selects this option, please submit your assets to MATE ROV Competition officials (see 6.1 Documentation) for submission guidelines. This [Option 1 - Tutorial](#) will provide you with additional information.

OPTION 2:

Aspiring AltSpaceVR World Builders - this is your opportunity to dive in! You create your own “corporate headquarters” world in AltSpace and share the world’s access code with MATE ROV Competition officials (see 6.1 Documentation) and we will create a portal from the MATE VR World to access it. How you design and populate your world is up to you! The only requirement is to include a portal from your world to the **MATE Welcome Center** so that visitors can return to MATE VR.

The following are resources for teams selecting either Option 2:

- See the 2021 MATE ROV Competition Resources section of the [MATE ROV COMPETITION VR WORLD](#)
- [AltSpaceVR World Building with Unity](#)

TIPS FOR EFFECTIVE WRITTEN AND ORAL COMMUNICATION

Communicating ideas about how to solve a problem and evaluating those ideas against competing alternatives is a critical skill for anyone entering the workplace. It is a skill that is directly linked to decision making about whether or not to hire (or fund) us and our ability to influence the work that we do.

The key to a successful technical documentation and engineering presentation is the way that critical thinking and engineering reasoning are communicated. You can think of the process as technical “storytelling.”

Technical storytelling includes the use of text, images, schematics, and data to effectively communicate the “story” of how your company brainstormed and evaluated ideas to come up with your solution (e.g. ROV, payload tools, and operational strategies) to the problem at hand (product demonstration tasks). It also involves organizing content to efficiently present your work and justify why you did what you did.

However, you should choose details with care. Each detail should help to answer the question “why is what you did the best solution for your company and for this competition?” Describe why a component in the system is critical and how you chose it. Include specifications or dimensions only if they help to explain the “why” and “how” you made choices. Keep in mind that a mechanical drawing with dimensions can replace a lot of text and in many cases do a better job telling details of the story than text.

That said, if something is hard to describe clearly and completely with two to three sentences, consider whether using an image may help. A good technical document balances text and images to provide lots of information concisely, which for a detailed understanding while being quick and easy to read. Remember that your reader is new to your design and needs to understand both what your design is

and the process you used to get there. Present text and images in a logical order that helps readers follow your development process and results.

Maintaining a project notebook is a good business practice that will help to capture ideas and document your company's progress – including your research, designs, trade studies, experiments, data, vehicle specifications, testing, expenditures, and donations. The notebook is also a place to keep track of your company member's contributions (time, support, etc.).

Along with your notebook, here are some items to consider as you prepare to tell your story:

- What was your company's "work breakdown structure" (tasks, time, and people)?
- What were the greatest constraints (schedule, budget, equipment, labor, logistics, etc.) on your design process?
- How did the product demonstration tasks and rules influence your design and decisions?
- What systematic process, such as a tradeoff matrix, did you use to evaluate competing design solutions?
- What were the most important design decisions you made and why?
- How did you arrive at your final power budget? What concessions, if any, did you have to make and why?
- How do you calibrate your sensors?
- If your vehicle uses software, where does the code execute? Describe the flow and format of the data.
- Did you have a noteworthy troubleshooting experience? Any problem or procedure that takes more than 20 minutes to figure out is worth understanding and writing down.

PART 6: SUBMISSION GUIDELINES AND KEY DEADLINES

6.1 Documentation

Companies advancing to the World Championship are required to submit technical documentation, a company spec sheet, a SID, a fluid power diagram (if fluid power is used), a non-ROV device design document, a non-ROV device SID, and a company safety review. In addition, companies may submit a JSA, documents supporting their corporate responsibility efforts, and assets for the MATE ROV Competition VR World workstations.

Regional competitions may not require all documentation. EXPLORER class companies participating in a regional competition should contact their [regional coordinator or visit their regional contest's website](#) to determine what documentation must be submitted for your regional and the date it is due.

NOTE for 2022!!!

The links provided in this section are for companies advancing to and submitting documentation for the World Championship. Regional coordinators will provide their own link for regional submissions.

Regional submissions sent to the MATE ROV Competition management team or to World Championship officials are NOT guaranteed to be forwarded to the regional coordinator.

DOC-006: All required documentation sent to the MATE ROV Competition officials MUST be in searchable PDF format (see <https://fd4686477cb19f983f54-68abf00cbc1a2cc111562c013cb867db.ssl.cf1.rackcdn.com/SearchablePDFs.pdf> for information about creating searchable PDFs.

DOC-007: The technical documentation may be up to 8 MB in size, the other documents are restricted to a maximum file size of 2MB.

DOC-008: All documents should use the following naming convention: School or organization name_company name_DOCUMENT TYPE_2022.pdf, where DOCUMENT TYPE is technical documentation, spec sheet, SID [type – electrical or fluid], non-ROV device design, company safety review, or JSA.

See [Documentation Submissions | MATE ROV Competition Website](#) for information on submitting your documentation. **Submit all of your final documents** in one email. Revised documents submitted at a later date will not be accepted. The MATE competition will use the date-stamp on your form to determine your initial submission.

Before submitting documentation, check to verify that all the files have been attached. Once submitted, companies should verify that all the proper documents were uploaded. If there was an error while submitting your documents, contact the MATE ROV Competition and upload **ALL** documents again.

DOC-009: For the World Championship, due date for the required documentation is 11:59 PM, Hawaii Time Zone, on May 26, 2022.

DOC-010: Companies will lose points on their initial safety and documentation review if documents:

- 1) Are submitted late
- 2) Exceed the size limit
- 3) Use improper naming conventions
- 4) Are not submitted on ONE form

6.1.1 Video Demonstration Requirements

DOC-011: See [Documentation Submissions | MATE ROV Competition Website](#) for information on submitting your demonstration videos.

DOC-012: For the World Championship, due date for the video demonstration submissions is 11:59 PM, Hawaii Time Zone, on May 15, 2022.

DOC-013: Videos must be submitted as links to a YouTube or Vimeo post. Companies may submit the specification and product demonstration as two separate videos. Note that the product demonstration portion must be a complete, uncut video.

The video MUST indicate the school/organization and the team name, as well as the competition year, 2022.

MATE competition organizers will review the videos and respond by May 20th. Video submissions will NOT be accepted after May 15th – NO EXCEPTIONS. Video conferences will not be scheduled after May 15th. If the video does not clearly demonstrate that the company's vehicle meets the specifications and accomplishes the tasks, the company is not eligible to participate in the World Championship. No extensions past the due date will be given for any reason.

MATE strongly encourages companies to submit their videos or arrange for a video conference with a MATE official well before May 15th. That way, if an issue is found, companies will have the opportunity to address the issue and submit an updated video, or schedule another video conference, before the May 15th deadline. **Note that it may take MATE up to 5 working days to evaluate a video submission or respond to a request to schedule a video conference.**

NOTE: By submitting your video demonstration links, you are giving the MATE ROV Competition permission to publish these video links on its web site.

6.1.2 Corporate Responsibility Documentation

DOC-014: See [Documentation Submissions | MATE ROV Competition Website](#) for information on submitting your corporate responsibility documentation.

DOC-015: The following naming convention should be used for corporate responsibility documentation: School or organization name_company name_Corporate Responsibility ##_2022, where ## is the number of the document uploaded. You can upload a variety of file types (pdfs, jpegs, etc.) and multiple files, but the size of each file should not exceed 2MB. Number each file to distinguish between them.

Before submitting documentation, companies should verify that all the files have been attached. If companies experience an error when submitting documents, contact the MATE ROV Competition and upload **ALL** documents again. Revised documents submitted at a later date will not be accepted. The MATE competition will use the date-stamp on your form to determine your initial submission.

DOC-016: For the World Championship, due date for the corporate responsibility documentation is 11:59 PM, Hawaii Time Zone, on May 26, 2022.

NOTE: By submitting your documentation, you are giving the MATE ROV Competition permission to

publish these documents on its web site.

6.1.3 Virtual Reality Assets

DOC-017: See [Documentation Submissions | MATE ROV Competition Website](#) for information on submitting your virtual reality assets.

DOC-018: The following naming convention should be used for virtual reality submissions: School or organization name_company name_Virtual_Reality_Asset ##_2022, where ## is the number of the asset uploaded. You can upload a variety of file types and multiple files. Number each file to distinguish between them.

Before submitting VR assets, check to verify that all the files have been attached. Once submitted, companies should verify that all the proper assets were uploaded. If there was an error while submitting your documents, contact the MATE ROV Competition and upload **ALL** documents again. Revised documents submitted at a later date will not be accepted. The MATE competition will use the date-stamp on your form to determine your initial submission.

DOC-019: For the World Championship, due date for the corporate responsibility documentation is 11:59 PM, Hawaii Time Zone, on May 26, 2022.

NOTE for 2022!!!

The MATE ROV Competition is not requiring documentation submission for image recognition in 2022.

6.2 KEY DEADLINES

Below is an updated summary of key dates and deadlines for the 2022 MATE ROV competition season. Note that EXPLORER regional competitions will have their own set of key dates and deadlines. For companies attending regionals, contact [your regional coordinator or visit your regional contest's website](#) for more information.

- December 1, 2021: Registration opens (note that registration for the World Championship and individual regional competitions will open as locations and dates are secured).
- April 26, 2022: Last day to register for the fluid power quiz.
- May 15, 2022: Last day to submit laser specifications, hydraulic fluid information, and pressure release valve specifications. Companies with regional competitions earlier than May 15 should plan to submit specifications early to allow at least 1 week for approval.
- May 15, 2022: EXPLORER class video demonstration submission deadline.
- May 26, 2022:
 - Technical documentation
 - Company spec sheet
 - SIDs (including electrical, fluid, Non-ROV Device)
 - Non-ROV device design document
 - Company safety review
 - Job site safety analysis (optional)

- Corporate responsibility documentation (optional)
- Assets OR access code for MATE ROV COMPETITION VR WORLD workstations (optional)