

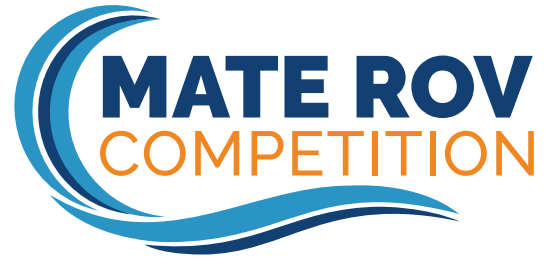

# DIVING IN



# 2023

# SCOUT CLASS



## BECAUSE TOGETHER



## OPPORTUNITY RUNS DEEP!



# COMPETITION MANUAL

Release: December 2022

## 2023 MATE ROV COMPETITION:

### ***UN DECADE OF THE OCEAN: DIVING IN TO INSPIRE SOLUTIONS BECAUSE TOGETHER OPPORTUNITY RUNS DEEP***

## **SCOUT CLASS COMPETITION MANUAL**

For general competition information, including a description of the different competition classes and eligibility requirements, visit [Compete](#).

## **CONTENTS**

<b>OVERVIEW.....</b>	<b>2</b>
<b>THINK OF YOURSELVES AS ENTREPRENEURS.....</b>	<b>3</b>
<b>PART 1: PRODUCT DEMONSTRATION .....</b>	<b>4</b>
<b>OVERVIEW.....</b>	<b>4</b>
<b>SCORING OVERVIEW .....</b>	<b>4</b>
<b>TIME.....</b>	<b>5</b>
<b>CONTEXT &amp; NEED .....</b>	<b>6</b>
<b>REQUEST FOR PROPOSALS (RFP) .....</b>	<b>7</b>
<b>SIZE RESTRICTIONS.....</b>	<b>14</b>
<b>PRODUCT DEMONSTRATION.....</b>	<b>14</b>
TASK 1: Marine Renewable Energy.....	14
TASK 2: Healthy Environments from the Mountains to the Sea.....	16
TASK 3: <i>MATE Floats! 2023</i> .....	21
PRODUCT DEMONSTRATION RESOURCES.....	23
PRODUCT DEMONSTRATION RESPONSIBILITIES .....	23
<b>PART 2: PRODUCT DEMONSTRATION PROP BUILDING INSTRUCTIONS &amp; PHOTOS .....</b>	<b>23</b>
<b>PART 3: VEHICLE DESIGN &amp; BUILDING SPECIFICATIONS .....</b>	<b>24</b>
<b>1.0 GENERAL .....</b>	<b>24</b>
<b>2.0 SAFETY .....</b>	<b>24</b>
2.1 Safety inspection protocol.....	25
2.2 Safety inspection completed .....	27
<b>3.0 SPECIFICATIONS.....</b>	<b>27</b>
3.1. Operational.....	27
3.2. Mechanical/Physical.....	28
3.3. Electrical .....	28
3.4 Onboard Electrical Power .....	30

3.5 Power Shutdown .....	30
3.6 Fluid Power.....	30
3.7 Control Systems.....	31
3.8 Cameras and monitors .....	31
3.9 Lasers.....	31
<b>PART 4: COMPETITION RULES.....</b>	<b>31</b>
4.1 GENERAL .....	31
4.2 PROCEDURAL.....	33
4.3 DESIGN & SAFETY CONSIDERATIONS .....	35
<b>PART 5: ENGINEERING &amp; COMMUNICATION.....</b>	<b>36</b>
5.1 COMPANY SPEC SHEET .....	37
5.2 TECHNICAL DOCUMENTATION .....	38
5.3 ENGINEERING PRESENTATION .....	39
5.4 MARKETING DISPLAY.....	40
5.5 CORPORATE RESPONSIBILITY .....	41
TIPS FOR EFFECTIVE WRITTEN AND ORAL COMMUNICATION.....	42
<b>PART 6: DOCUMENTATION.....</b>	<b>43</b>



This work is licensed under a [Creative Commons Attribution-NonCommercial-NoDerivatives 4.0 International License](https://creativecommons.org/licenses/by-nc-nd/4.0/). Under this license you may download this document. Please give credit to MATE II. You may not use these materials for commercial purposes without written permission from MATE II. Please click on the Creative Commons link above for license details.

[www.materovcompetition.org](http://www.materovcompetition.org)  
[www.mateii.org](http://www.mateii.org)

## OVERVIEW

### From Technical to Teamwork, Problem-Solving, Creativity, and Critical Thinking: MATE Develops Skills for Success in the Workforce

As you prepare to harness the energy of offshore wind and solar, ensure healthy ecosystems from the mountains to the sea, and deploy technologies to monitor ocean conditions, make sure to take the time to think about the skills that you are developing to allow you to tackle these tasks. These are the skills that you will take with you along your educational journey and, eventually, into the workplace.

They also happen to be the skills that are in high demand by employers around the globe. Machine learning, data analytics, AI, video marketing, critical thinking, creativity, collaboration, time management, and leadership – articles published by [LinkedIn](https://www.linkedin.com/) and [Forbes Magazine](https://www.forbes.com/) highlight these technical and employability

(aka “soft”) skills as the most “in-demand for the next 10 years” and, likely, beyond.

Entrepreneurs possess a number of these skills and more, including the ability to understand the wide range of business operations (from using data to make financial decisions to researching and evaluating potential design solutions and producing content for social media); acknowledge your strengths (and weaknesses!); work as part of a team; and apply technical knowledge and skills in new and creative ways. By developing good business sense, a mindset for innovation and collaboration, and an understanding of how to consider environmental, social, and governance (ESG) factors when making business decisions, you will be well prepared for the global workplace and ready to tackle today’s (and tomorrow’s!) challenges.

As you read through this manual you will see the following icons:\*



These icons correspond to the employability (orange) and ROV-specific (green) knowledge and skills that you gain as you build your ROV and prepare for the competition. Throughout the manual they are matched with the various competition requirements – from the Product Demonstration to Engineering and Communication – that help to develop each of these skills.

## THINK OF YOURSELVES AS ENTREPRENEURS

The MATE ROV Competition not only encourages you to think about the skills that you develop, but also challenges you to think of yourself as an entrepreneur and the skills that being one requires and transform and organize your team into a start-up company. Use the following questions as a guide to assist you with this process:

- What is your company name?
- Who are its leaders, including the:
  - CEO (chief executive officer – the leader)
  - CFO (chief financial officer who oversees the budget and spending)
- Who manages Government and Regulatory Affairs (i.e. who’s in charge of reviewing the competition rules and making sure that they are understood and followed by everyone)?
- Who is responsible for research and development (aka R&D)?
- Who is responsible for system(s) engineering? Design integration? Testing? Operations?
- Who is responsible for fund-raising, marketing, and media outreach?
- Who is the company’s ESG research and engagement analyst?

- What other positions might you need? (Depending on your personnel resources, more than one person may fill more than one role.)
- What products and services do you provide?
- Beyond MATE, who are your potential clients?

## “DELIVER, TOGETHER, THE OCEAN WE NEED FOR THE FUTURE WE WANT!”

The [MATE ROV Competition’s philosophy](#) is about student learning. It is about the knowledge and skills that you develop by participating in the competition and how that knowledge and those skills prepare you for your future education and career in the ocean STEM workforce – and [beyond](#).

As you think about your future education and career plans, the challenge put before you today is how to apply your knowledge and skills to tackling the competition mission tasks so that we can “deliver, together, the ocean we need for the future we want!”

Again this year the MATE ROV Competition is highlighting the [United Nations Decade of Ocean Science for Sustainable Development](#) and aligning its mission tasks with one or more of the [17 UN Sustainable Development Goals](#). This 2023 MATE ROV Competition also continues to inspire ESG in order to do “good for good” for our ocean planet and global community. These are the “clients” who once again put together a request for proposals (RFP), the specifics of which are included below.

## PART 1: PRODUCT DEMONSTRATION



## OVERVIEW

SCOUT class companies will take part in ONE product demonstration that consists of three distinct tasks:

**TASK #1: Marine Renewable Energies**

**TASK #2: Healthy Environments from the Mountains to the Sea**

**TASK #3: MATE Floats!**

**NOTE:** Regional competitions may not include all 3 tasks of the product demonstration; regional competitions may also give companies more than one attempt at the product demonstration. Contact [your regional coordinator or visit your regional contest’s website](#) to determine what will take place at your regional competition. Regardless, the product demonstration score will be added to your [ENGINEERING & COMMUNICATION](#) and [SAFETY](#) scores to determine your total, overall score for the competition.

## SCORING OVERVIEW

The competition consists of product demonstrations, engineering and communication, and safety with the following scoring breakdown:

- **Product Demonstrations**
  - 200 points (max), plus a time bonus
- **Engineering & Communication**
  - Technical documentation – 50 points (max)
  - Engineering presentations – 50 points (max)
  - Marketing displays – 50 points (max)
  - Company Spec Sheet – 20 points (max)
  - Corporate Responsibility – 20 points (max)
- **Safety** – 10 points (max)

**TOTAL POINTS = 400**

**NOTE:** Regional contests may not require all of the Engineering & Communications components or offer the opportunity to earn points for Corporate Responsibility. Contact [your regional coordinator or visit your regional contest's website](#) for more information.

## TIME

The time that your company will have to complete the product demonstration will depend on your regional event. In general, the product demonstration time consists of a 3-minute set-up period, a 10-minute performance period, and a 2-minute demobilization period. Contact [your regional coordinator or visit your regional contest's website](#) to determine how your demonstration will be timed and how long you will have to set up, complete the tasks, demobilize, and exit the station.

At any time during the product demonstration you may pilot your ROV to the surface and remove it from the water for things such as buoyancy adjustments, payload changes, and troubleshooting. However, the product demonstration clock will NOT stop. The only time the clock will stop is if a judge determines that there is an issue that is beyond your control. Otherwise, the clock will only stop after all of the tasks are successfully completed, the ROV has returned to the surface under its own power so that it touches the side of the pool, and a member of your company at the product demonstration station has physically touched the vehicle. Your ROV is not required to return to the surface between tasks.

## TIME BONUS

Companies will receive a time bonus for each product demonstration run if you:

- 1) successfully complete the tasks,
- 2) return your ROV to the surface under its own power so that it touches the side of the pool, and
- 3) physically touch your vehicle before the product demonstration time ends.

How the time bonus is calculated will depend on your regional event. Contact your [regional coordinator](#) for more information.



## CONTEXT & NEED

This competition season the MATE ROV Competition is celebrating! MATE Inspiration for Innovation and the Marine Technology Society are joining forces to expand our reach, maximize our partnerships and resources, and grow our missions. For MATE, it's a homecoming; the competition was created in 2001 in partnership with the MTS ROV Committee as a workforce development program for the offshore maritime industry. We have evolved and expanded over the years, but the mission to inspire and develop the next generation of ocean professionals remains at our core.

In addition to the celebration, join us as we continue to highlight the [United Nations Decade of Ocean Science for Sustainable Development](#), embrace and inspire ESG, and challenge our global community of learners to come together to imagine, innovate, and create solutions to the problems that impact us all.

As we shared last year, the United Nations proclaimed a *Decade of Ocean Science for Sustainable Development* (2021-2030) to support efforts to reverse the cycle of decline in ocean health and to gather the global community behind a common goal: improving conditions for the sustainable use and development of our world ocean.

Like last year, the three 2023 competition mission tasks focus on SOLUTIONS – from marine renewable energies to Blue Carbon, “prescriptions” for diseased coral, conservation programs for endangered species, and GO-BGC floats to monitor ocean health. We begin this season with optimism that together we can inspire, innovate, and create technology solutions to mitigate the impacts of climate change and pave the way to a sustainable future. And with the ocean observations and scientific research to support us, we are also optimistic that we can influence mindsets and guide communities to adapt practices for the good of us all.

And again this MATE ROV Competition season the “client” is us – our global community – and each task area included within the request for proposals (RFP) aligns with one or more the [17 UN Sustainable Development Goals](#). While not specific to the Decade of the Ocean, these goals offer a blueprint to achieve a better and more sustainable future for all. And like last year, each task also embraces [ESG](#) – the environmental, social, and governance factors that more and more companies and organizations are taking into consideration when making business and management decisions.

The MATE ROV Competition is challenging its community to design and build a remotely operated vehicle and the necessary sensors, tooling, and complementary technologies to combat climate change, provide clean energy, monitor ocean health, and heal and protect our aquatic habitats from the mountains to the sea so that we can “[deliver, together, the ocean we need for the future we want!](#)”

## REQUEST FOR PROPOSALS (RFP)

### 1. General

#### a. Marine Renewable Energy

*UN Sustainable Development Goals:*

*#7 Affordable and Clean Energy*

*#12 Responsible Consumption and Production*

This appeared in last year’s competition manual and it’s worth repeating – marine renewable energies (MREs), such as offshore wind farms, tidal turbines, wave energy converters, and floating solar panels, play a key role in mitigating the effects of climate change and paving the pathway to a sustainable future. MREs contribute to the production of low-carbon renewable energy around the world and are an important ally in the fight against climate change.

Innovative minds employed at organizations that embrace ESG are exploring the idea of installing floating solar “parks” amongst existing offshore wind farms. This would allow the solar arrays to use the existing infrastructure (including resident ROVs for cleaning and maintenance), tie into the grid transporting power to shore, and minimize the increase to the overall footprint of the combined assets. The last feature in that list will be particularly advantageous for overall management and safety, especially when it comes to ocean-going vessels and charismatic megafauna (whales!) traversing the area.

That said, the offshore wind farm serviced in last year’s mission challenge is preparing to welcome a new “crop” – floating solar arrays. Installing these among established floating turbines has never been done before and certainly presents a variety of challenges, but that will not prevent us from tasking MATE competitors to – borrowing a line from long-time partner [Oceaneering International](#) – “solve the unsolvable” find solutions that help to reduce CO2 emissions.



*SolarDuck floating panel solar arrays ([SolarDuck and Partners to Build and Test Offshore Floating Solar Platform 'Merganser' | Energy | News \(oceannews.com\)](#))*



***b. Healthy Environments from the Mountains to the Sea***

***Coral Reefs and Blue Carbon***

***Inland Lakes and Waterways***

***UN Sustainable Development Goals:***

***#13 Climate Action***

***#14 Life Below Water***

A drop of water that begins its journey in an inland pond high in the Rocky Mountains – or even higher up in Lake Titicaca in the Peruvian Andes – will eventually make its way to the sea, where it could end up flowing over a coral reef and becoming a genetic “fingerprint” of the organisms that make their home there. Or where it once flowed through the gills of Redbelly Dace hiding in grasses of a wetland, it could now flow over the gills of seahorses anchoring themselves on blades of seagrasses or the chain links of an [Eco-Mooring System](#).

Students at the [St. Vrain Valley Innovation Center](#) in Longmont, CO appreciate this first-hand. Partnering with [Boulder County Parks and Open Space](#), [Colorado Parks and Wildlife](#), and the [Ocean First Institute](#), among other state and regional organizations, students played a significant role in a real-world conservation project to reintroduce a native fish species, the Northern Redbelly Dace. After rearing dace fry in laboratory aquaria, students monitored water quality both in-house and in the field and released the fry in a restored wetland habitat in an area safe from predators.

Innovation Center students have also helped to ensure the integrity and safety of another habitat – the Dillon Reservoir Recreation Area. Starting with an OpenROV, students have inspected ropes that hold the buoys that mark the dam water intakes – and may one day use a [BlueROV2](#) to help to uncover a mystery. In the late 1950s, the Denver Water Board voted to build a dam to secure water for the Front Range; the Old Town of Dillon was flooded. More than 70 years later it sits as a western “ghost town” at the bottom of the lake, with many buildings and homes – and their contents – still intact.

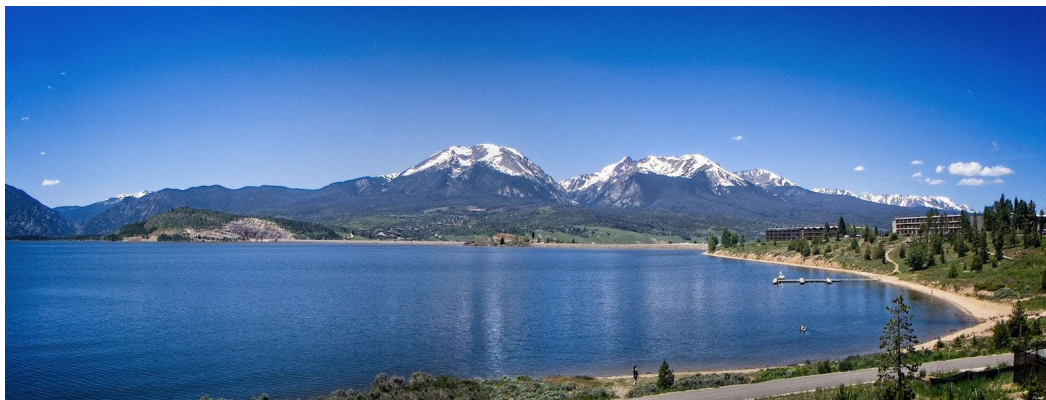

*Dillon Reservoir Recreation Area*

[\*\(Dillon Reservoir Recreation Area – Dillon and Frisco, CO | Biking, Boating, Camping, Fishing, Hiking on Lake Dillon in Summit County \(uncovercolorado.com\)\)\*](#)

Another project that Innovation Center partners have been involved with takes place more than 7,200 kilometers away from Dillon Reservoir and the restored habitat of the Redbelly Dace. Lake Titicaca is home to [the world's largest entirely aquatic frog](#); its classification as endangered by international conservation authorities means that not just the frogs, but also the lake is under significant threat. The Denver Zoo is working to understand and mitigate these threats through research, conservation breeding, community engagement, capacity building, and more. Like the Northern Redbelly Dace, the conservation of the Lake Titicaca giant frog is critical for both the species and the environments that they support.



*The Lake Titicaca giant frog ([Peru – Denver Zoo](#))*

Not quite so far away from the Rockies, scientists at the [Smithsonian Marine Station](#) in Fort Pierce, FL, are evaluating various treatments to heal diseased areas of coral reefs. While still unclear if the culprits are bacterial, viral, or fungal, the detrimental effect they have is exacerbated by the warming waters of climate change. The “prescriptions” these researchers are studying include probiotics to enable the corals to heal themselves and UV light to irradiate and kill diseased coral tissue. Unlike antibiotics that do not provide lasting protection and may encourage the selection of antibiotic resistant pathogens, probiotics could colonize a host and provide lasting protection to diseased corals. And while UV irradiation may also damage healthy coral tissue, their studies have shown that healthy coral tissue can more readily heal.

Smithsonian Institution scientists are also using [environmental DNA](#) (aka “eDNA”) as genetic fingerprints to determine the species that inhabit these reefs. This information allows them to better understand the diversity of species (without having to capture them) and make better informed decisions about their management and conservation.



*A plastic bag with weighted line along the bottom is used to “tent” an area of diseased coral that will soon receive a dose of probiotic treatment.  
(Hunter Noren, Nova Southeastern University)*

Like coral reefs, seagrass meadows are also important habitat for a variety of species – from seahorses to sea turtles. And as was shared last year, seagrasses are extremely effective at absorbing and storing CO<sub>2</sub>, which makes them key allies in combating climate change and important environments to protect and conserve.

The water cycle is a process that most of us have memorized (or will soon memorize!) to pass our middle school grade science test. However, if we allow it, it can also serve as a reminder of the interconnectivity of our Blue Planet and how changes thousands of miles away from a coastline, or thousands of miles away from the open seas, can impact each other in either positive or negative ways. The UN Decade of the Ocean, as well as the location of the 2023 World Championship, provides the opportunity to challenge competitors around the globe to recognize that climate change isn’t limited to oceans and coastal communities; it impacts inland lakes and remote mountain villages as well.

### ***c. MATE Floats!***

***UN Sustainable Development Goal:  
#13 Climate Action***

The goal of the [National Science Foundation \(NSF\)-funded GO-BGC Project](#) is to build a global network of chemical and biological sensors that will monitor ocean health. Scientists, engineers, and technicians from multiple organizations are using NSF grant funds to build and deploy 500 robotic ocean-monitoring floats around the globe. The temperature, depth, and bio-geochemical information that these floats collect will add significantly to the data needed to better understand ocean processes and predict the consequences of climate change.

The primary focus of the competition is, obviously, on engineering ROVs. However, the opportunity to present competitors with the challenge of designing and building another type of underwater technology, one that contributes to observations and research critical to understanding the impact of climate change, could not be missed.

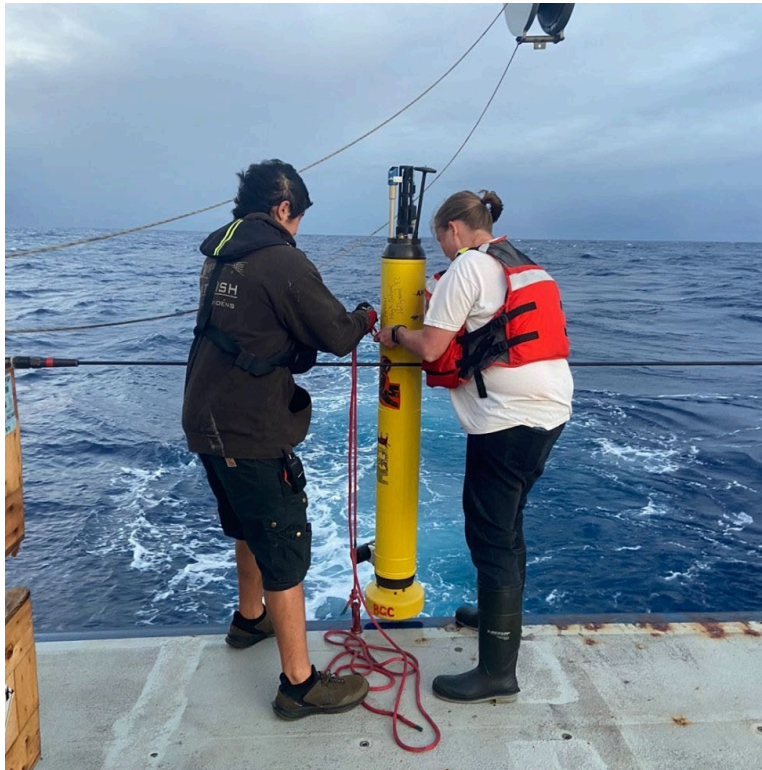

Deploying a GO-BGC float in the middle of the Pacific Ocean ([\(20+\) Global Ocean Biogeochemistry Array | Facebook](#))

## THIS IS WHERE YOUR MISSION BEGINS.

### *a. Mission Scope and Purpose*

This and the following sections contain the technical specifications and requirements for ROV services needed to support the *UN DECADE OF THE OCEAN: DIVING IN TO INSPIRE SOLUTIONS BECAUSE TOGETHER OPPORTUNITY RUNS DEEP*. In 2023, ROV services include:

#### **1) TASK 1: Marine Renewable Energy**

##### **UN Sustainable Development Goals:**

##### **#7 Affordable and Clean Energy**

##### **#12 Responsible Consumption and Production**

- Position a solar panel array between amongst floating wind turbines
- Moor the panel array to an anchor point
- Connect the floating solar panel array to grid

- Remove biofouling from the floating wind turbines

## 2) TASK 2: Healthy Environments from the Mountains to the Sea

### UN Sustainable Development Goals:

#### #13 Climate Action

#### #14 Life Below Water

#### Coral Reefs and Blue Carbon

- Collect a water sample from above the coral head to simulate collecting eDNA
- Use the eDNA data to identify coral reef species
- Place a tent over diseased coral and inject a “probiotic” fluid underneath tent
- Install an Eco-Mooring to protect seagrass and seahorse habitat

#### Inland Lakes and Waterways

- Transport the fry to safe release area
- Allow the fry to acclimate to local conditions
- Release the fry
- Recover a damaged rope and buoy
- Place a new rope and buoy in the designated area
- Attach a lift bag to the container
- Inflate the lift bag to lift the container and return it to the surface, side of the pool
- Install a long-term camera into the designated area on the bottom of the lake

## 3) TASK 3: *MATE Floats!*

### UN Sustainable Development Goal:

#### #13 Climate Action

- Adopt-a-float
- Pull a pin to simulate the float ascending to the surface
- Recover the float to the surface, side of the pool
- Graph water temperature data versus depth

## 2. Specifications

See the specific tasks described below as well as the [VEHICLE DESIGN & BUILDING SPECIFICATIONS](#) and [COMPETITION RULES](#) sections.

## 3. Maintenance and Technical Support

The company will guarantee the ROV for the duration of the product demonstrations. Repair or replacement will be at the company’s expense. The company will provide at least one day of technical support to deal with any issues.

## 4. Shipping and Storage

Delivery of the ROV will be no later than the date of the nearest regional contest.



## 5. Evaluation Criteria

- a. Technical documentation
- b. Engineering presentation
- c. Marketing display
- d. Company spec sheet
- e. Product demonstration
- f. Safety

## 6. References

### a. GENERAL

- [United Nations Decade of Ocean Science for Sustainable Development](#)
- [17 UN Sustainable Development Goals](#)
- [A Hotter Future Is Certain, Climate Panel Warns. But How Hot Is Up to Us.](#)
- [ESG \(environmental, social and governance\)](#)
- [Ocean energy: An important ally in the fight against climate change](#)
- [Marine Renewable Energy](#)
- [The Blue Carbon Initiative](#)

### b. TASK 1: Marine Renewable Energy

- [The Technology of Offshore Wind Power and the Morro Bay Wind Farm](#)
- [RWE and SolarDuck to Explore and Develop Offshore Floating Solar Parks Globally \(oceannews.com\)](#)
- [Floating Solar Anchoring and Mooring](#)
- [SolarDuck – Offshore Solar Energy](#)

### c. TASK 2: Healthy Environments from the Mountains to the Sea

- [Scientific breakthrough could save Florida's threatened coral reefs](#)
- [Environmental DNA \(eDNA\) | Center for Ocean Solutions](#)
- [Stony coral tissue loss disease \(SCTLD\)](#)
- [New Mapping Tools Helping to Protect Seagrass](#)
- [Studland Bay 'eco-moorings' set up to protect seahorses](#)
- [Northern redbelly dace recovery](#)
- [Northern redbelly dace release video](#)
- [Summit County Water Rescue Team deploys new, state-of-the-art underwater drone to help with rescues](#)
- [Peru - Denver Zoo](#)
- [Lake Titicaca giant frog: Scientists join forces to save species](#)

d. **TASK 3: MATE Floats!**

- [GO-BGC | Global Ocean Biogeochemistry Array](#)
- [2021 MATE Floats! | MATE ROV Competition Website](#)
- [Adopt-a-Float Newsletters | GO-BGC](#)

**IMPORTANT NOTE:** Questions about production demonstrations and design and building specifications should be sent to the [Competition Technical Manager](#). Question, answers, and official rulings will be posted on the MATE ROV Competition [Q&A and Official Ruling Document](#). This allows all companies to see the questions and answers and helps to avoid duplicate questions. That said, please make sure that your question(s) has not already been asked – and answered – before emailing. It is up to the companies to read, comprehend, and comply with ALL rulings posted on the site.

## SIZE RESTRICTIONS

None. SCOUT class companies are not restricted on the size of their vehicle. Companies must be able to transport the vehicle and associated equipment to the product demonstration station and to the engineering presentation area by hand. ROV systems must be capable of being safely hand launched.

## PRODUCT DEMONSTRATION

### TASK 1: Marine Renewable Energy

UN Sustainable Development Goals:

- #7 Affordable and Clean Energy
- #12 Responsible Consumption and Production

This task involves the following steps:

**1.1 Install a floating solar panel array**

- Position a solar panel array amongst floating wind turbines – 10 points
- Moor the panel array to an anchor point – 10 points
- Connect the floating solar panel array to the power grid
  - Remove the power port cover – 5 points
  - Install the power line connector into the power port – 10 points

**1.2 Remove biofouling from the foundation and mooring lines of floating wind turbines**

- Remove 1 to 2 biofouling from turbines – 5 points
- Remove 3 to 5 biofouling from turbines – 10 points
- Remove 6 biofouling from turbines – 15 points

Total points = 50 points

### Product Demonstration Notes:

Companies must complete the steps of Task 1.1: Install a floating solar panel array in order. Companies may not skip any steps of this task and continue with further steps of Task 1.1.

### **Task 1.1 Install a floating solar panel array**

The steps of this task must be done in order. Companies cannot proceed to the next step until they have successfully completed the previous step. Companies must first position the solar panel array between two floating wind turbines. The solar panel array will be floating on the surface, side of the pool at the start of the product demonstration. The solar panel array will be constructed from a triangular piece of corrugated plastic sheeting with two lengths of PVC extending down into the water. Flotation will keep the array on the surface of the pool.

Two floating wind turbines will be positioned in the product demonstration area. The floating wind turbines will be constructed from PVC pipe with flotation attached. The surface side of the two floating wind turbines will be constructed from ½-inch PVC pipe with flotation attached. Propeller blades for the floating wind turbines will be simulated by three 30 cm lengths of corrugated plastic sheeting. The turbines will be connected by a rope to a ½-inch framework on the bottom. The rope will be just long enough to reach from the floating turbines to the PVC framework on the bottom.

Companies will receive 10 points when they successfully position the solar panel array between the two wind turbines. Successfully positioning the solar panel between the wind turbines is defined as any part of the solar panel array crossing the line between the two floating wind turbines.

Once the solar panel array has been positioned, companies must moor the solar panel array to an anchor point located on the bottom of the pool and attached to the PVC framework that holds the floating wind turbines. The anchor point will be simulated by a ½-inch PVC framework covered in Velcro hooks. The mooring connection will be attached to one of the PVC pipes extending down from the solar panel array. The mooring connector will be constructed from a ½-inch PVC tee covered in Velcro loops. Velcro loops inside the PVC pipe extending down from the solar panel array will hold the connector in place. The mooring connector will be secured to the solar panel array by a rope. The rope will be 1.25 times the depth of the pool in length. Companies must remove the mooring connector from the array and attach it to the anchor point on the bottom.

Companies will receive 10 points for successfully attaching the mooring connector to the anchor point. Successfully attaching the mooring connection to the anchor point is defined as the Velcro loops on the connector secured to the Velcro hooks on the anchor point. The Velcro connection can be made anywhere on the anchor point, but it must stay attached after the vehicle backs away from the anchor point.

After the mooring connector has been successfully attached to the anchor point, companies must connect the floating solar panel array to the power grid. The power connector, also attached to the underside of the solar panel array, will be constructed from ½-inch PVC pipe. A rope will secure the power connector to the solar panel array on the surface. The power port will be constructed from 3-inch pipe and protected with a cover

constructed from corrugated plastic sheeting. The power port will be protected with a cover constructed from corrugated plastic sheeting. A handle on the power port cover will be constructed from ½-inch PVC pipe.

Companies will receive 5 points for successfully removing the power port cover. Successfully removing the power port cover is defined as the corrugated plastic sheeting no longer covering the 3-inch pipe of the power port.

After removing the power port cover, companies must install the power connector into the power port. Companies will receive 10 points for successfully installing the power connector into the power port. Successfully installing the power connector is defined as the power connector no longer in contact with the ROV and the ½-inch PVC pipe of the connector inside of the 3-inch pipe of the port.

### **Task 1.2 Remove biofouling from the floating wind turbines**

Companies must remove biofouling from the floating wind turbines. There will be two types of biofouling on the floating wind turbines: encrusting marine growth and algal marine growth. Encrusting marine growth will be simulated by a ½-inch PVC cross painted red. A 2 cm x 2 cm square of Velcro loops will be attached to the ½-inch cross. The floating wind turbine will have a 1.0 cm x 0.8 cm square of Velcro hooks attached to it. The Velcro loops on the cross will be attached to the Velcro hooks on the floating wind turbine. The algal marine growth will be simulated with pipe cleaners. The pipe cleaners will have a loop at one end to act as a grab point. The other end of the pipe cleaners will be inserted into holes drilled into the ½-inch PVC pipe of the floating wind turbines. The biofouling, both encrusting and algal, will be found either on the PVC pipe of the floating turbine or on the ropes holding the turbines in place. The biofouling attached to the PVC pipe of the wind turbines will be at least 20 cm below the surface of the water.

Six biofouling will be located on the two floating wind turbines. Companies that successfully remove all six biofouling will receive 15 points. Companies that successfully remove 3 to 5 biofouling will receive 10 points. Companies that remove 1 or 2 biofouling will receive 5 points. Successfully removing a biofouling is defined as the ½-inch PVC cross or pipe cleaners no longer in contact with the PVC pipe or rope of the floating wind turbine. Biofouling is not considered debris and may be left in the pool at the end of the product demonstration time.

## **TASK 2: Healthy Environments from the Mountains to the Sea**

### **UN Sustainable Development Goals:**

**#13 Climate Action**

**#14 Life Below Water**

**This task involves the following steps:**

### **Task 2A: Coral Reefs and Blue Carbon**

#### **2.1 Identify reef organisms using eDNA**

- **Collect a water sample from above the coral head to simulate collecting eDNA – 5 points**
- **Return the water sample to the surface, side of the pool – 5 points**

- Use the eDNA data to identify two coral reef fish species – 5 points each, 10 points total

## 2.2 Administer Rx to diseased corals

- Light
  - Irradiate the diseased area of coral with simulated UV light – 10 points
- Probiotics
  - Place a tent over the diseased area of coral – 10 points
  - Insert a syringe into a port to simulate injecting a “probiotic” fluid into the tent – 10 points

## 2.3 Monitor and protect seagrass habitat

- Install an Eco-Mooring system to protect seagrass and seahorse habitat – 5 points
- Secure the Eco-Mooring by rotating it 360 degrees – 5 points

## Task 2B: Inland Lakes and Waterways

### 2.4 Reintroduce endangered native Northern Redbelly Dace fry

- Transport the fry to release area – 5 points
- Allow the fry to acclimate to local conditions – 5 points
- Release the fry – 5 points each, 10 points total

### 2.5 Ensure the health and safety of Dillon Reservoir

- Replace a damaged buoy rope
  - Recover a damaged buoy rope – 5 points
  - Place a new rope and buoy in the designated area – 5 points
- Recover a container from the bottom of the reservoir
  - Attach a lift bag to the container – 10 points
  - Inflate a lift bag to lift the container – 5 points
  - Return the container to the surface, side of the pool – 5 points

### 2.6 Monitor endangered Lake Titicaca giant frogs

- Install a long-term camera into the designated area on the bottom of the lake – 10 points

**Total points = 120 points**

## Product Demonstration Notes:

### Task 2.1 Identify reef organisms using eDNA

Companies must first collect a water sample. The water sample will be constructed from a 1 ½-inch length of PVC pipe with end caps on each end. A rope will act as a grab point for the water sample. Companies will receive 5 points for successfully collecting the water sample. Successfully collecting the water sample is defined as the 1 ½-inch PVC pipe under control of the ROV and no longer in contact with the bottom of the pool.

Companies must then return the water sample to the surface, side of the pool. Companies will receive 5 points for successfully returning the water sample. Successfully returning the water sample is defined as the sample out of the water and placed on the pool deck.



Once the water sample has been successfully collected and returned to the surface, companies may open the PVC end caps and retrieve a laminated sheet with two eDNA code sequences representing DNA base pairs on the Cytochrome Enzyme 1 gene, or CO1 gene. Companies must compare the eDNA code sequences received to those of known coral reef fish species. The Coral Reef Fish Species Handbook will have a list of ten known coral reef fish species and their CO1 gene DNA code sequences. Companies that successfully identify the two coral reef fish species from their eDNA code sequences will receive 5 points for each successful identification, 10 points total. Successfully identifying the coral reef fish species is defined as one company member identifying, by common name and genus/species, both of the unknown eDNA samples. A link to the Coral Reef Fish Species Handbook can be found under the [PRODUCT DEMONSTRATION RESOURCES](#) section of this manual.

### **Task 2.2 Administer Rx to diseased corals**

Companies must irradiate a diseased area of the coral with simulated UV light. The UV light source will be simulated by ½-inch PVC pipe, with a 1-inch end cap covered in Velcro hooks on one end. This pipe will be located on the surface, side of the pool at the start of the product demonstration run. The coral head will be simulated by 2-inch end cap and 2-inch pipe attached to a ½-inch PVC framework at the bottom of pool. The 2-inch end cap and pipe will be covered in Velcro loops. Companies must carry down the light source and attach the light to the coral head, which will simulate irradiating the coral with UV. Companies will receive 10 points when they successfully irradiate the diseased area of the coral with simulated UV light. Successfully irradiating the diseased area is defined as the simulated UV light attached by Velcro to the coral head. The simulated UV light must remain attached to the coral head after released from the ROV.

Companies must attempt to heal a diseased coral by placing a tent over the coral head, inserting a syringe into a port and injecting a “probiotic” fluid into the tent to heal the coral. The tent will be constructed from a framework of ½-inch PVC pipe with corrugated plastic sheeting as walls. 3-inch pipe at the top of the tent will serve as a port to insert a syringe and tubing and inject the probiotic fluid.

Companies must first place a tent over the diseased area of coral. The tent will be located on the surface, side of the pool at the start of the product demonstration. Companies will receive 10 points when they successfully place the tent over the diseased area of coral. Successfully placing the tent is defined as the base of the tent against the bottom of the pool, completely covering the plastic bowl of the coral head. No part of the tent should be propped on top of the coral head.

Once the tent has been successfully placed, companies must insert a syringe into the port at the top of the tent. The syringe will be simulated by ½-inch PVC. A rope handle will act as a grab point for the syringe. Colored tape will be wrapped around the bottom end of the syringe. Companies may not place the syringe inside of the port prior to placing the tent. Companies must successfully place the tent, then insert the syringe into the port. Companies will receive 10 points for successfully inserting the syringe into the port. Successfully inserting the syringe into the port is defined as the colored tape wrapped around the bottom end of the syringe completely within the PVC pipe of the port.

### **Task 2.3 Monitor and protect seagrass habitat**

Companies must install an Eco-Mooring system to protect the seagrass and seahorse habitat. The base of the Eco-Mooring will be “installed” on the bottom of the pool. The base will be constructed from a 3-inch to 2-inch adapter and 2-inch PVC pipe attached to a ½-inch PVC pipe base. The Eco-Mooring will be on the surface, side of the pool at the start of the product demonstration. The Eco-Mooring will be constructed from ½-inch PVC pipe. One portion of the handle of the Eco-Mooring will be painted red. Companies must install the Eco-Mooring into the base and once installed, rotate the Eco-Mooring 360° to simulate digging it into the sediment. Companies will receive 5 points for successfully installing the Eco-Mooring. Successfully installing the Eco-Mooring is defined as the mooring inserted into the base. Once inserted into the base, companies must secure the Eco-Mooring. Companies that successfully secure the mooring will receive 5 points. Successfully securing the Eco-Mooring is defined as the mooring turned 360° while in the base. The station judge must be able to see the handle of the Eco-Mooring, with one length of PVC painted red, turn 360° while inserted into the base.

#### **Task 2.4 Reintroduce endangered native Northern Redbelly Dace fry**

Companies must transport the fry to the designated release area. The designated release area will be a 40 cm green colored square constructed from ½-inch PVC pipe. Companies are required to create a container to transport the fry; companies may not carry the fry directly in a gripper. Companies can create a container mounted to their ROV, or companies can create a container that can be carried down in a gripper and released from the ROV. Northern Redbelly Dace fry will be simulated by [rubber fishing lures](#) whose hooks have been removed. Two fry will be available at the mission station and can be placed inside the company’s container during the 5-minute set up period. Companies will receive 5 points when they successfully transport the fry to the release area. Successfully transporting the fry to the release area is defined as the container with the fry, or the ROV with the fry onboard, touching the bottom of the pool within the designated release area. Any part of the ROV or container with the fry may touch any point inside the 40 cm square.

Companies must allow the fry time to acclimate to local conditions. The container with the fry, or the ROV with the fry onboard, must remain within the safe release area for 10 seconds. Companies will receive 5 points for successfully acclimating the fry to local conditions. Successfully acclimating the fry to local conditions is defined as any part of the container, or any part of the ROV with the fry on board, within the designated area for 10 seconds. The entire container or ROV does not need to be within the designated area. The container or the ROV with the container on board must be within the safe area for 10 continuous seconds. If the container or ROV drifts completely out of the safe area, the 10 second timer will restart. Companies are allowed to drop their container in the safe area and move on to other tasks.

Once the fry have acclimated to local conditions, companies must release the fry into the safe area. Companies will receive 10 points when the fry are successfully released, 5 points each for each fry. Successfully releasing the fry is defined as both fry on the bottom of the pool within the designated area. If a fry does not successfully released in the designated area, companies may not try to pick up the fish and try again.

If a company chooses to transport the fish in a container that is dropped into the safe area, that container would be considered debris. The container must be removed from the pool or collected off the bottom under control of the ROV when mission time ends, to avoid penalty points for leaving debris in the pool.

### **Task 2.5 Ensure the health and safety of Dillon Reservoir**

Companies must replace a damaged rope buoy rope. Both the damaged and new buoy rope will be constructed from rope attached to a ½-inch PVC base and a float. The length of the rope will be long enough for the flotation to be on the surface when the ½-inch PVC base is in the designated area. The designated release area will be a yellow colored 40 cm square constructed from ½-inch PVC pipe.

Companies must recover the damaged buoy rope. Companies may grab and carry the buoy rope by any method they wish. Companies will receive 5 points when the buoy rope is successfully recovered. Successfully recovering the buoy rope is defined as the buoy removed from the pool and placed on the pool deck.

Companies must place the new buoy rope into the designated area. A new buoy rope will be located at the station during set up. Companies will receive 5 points for successfully placing the new buoy rope into the designated area. Successfully placing the new rope in the designated area is defined as the base of the new buoy rope completely within the PVC pipe of the designated area. No portion of the base can be outside or on top of the pipe of the designated area.

Companies must also recover a heavy container from the bottom of the pool. The container will be simulated by a length of 3-inch PVC pipe with a 2-lb dive weight attached on the inside of the pipe. A U-bolt will act as a grab point to attach a lift bag to the container.

Companies must first attach a lift bag to the container. The lift bag will be constructed from 3-inch PVC pipe with a knock-out cap glued to one end. A rope at the other end of the 3-inch pipe will run through a length of ½-inch PVC pipe with a #6 screw hook attached to it. Companies will receive 10 points for successfully attaching the lift bag to the container. Successfully attaching the lift bag to the container is defined as the lift bag no longer in contact with the vehicle, the screw hook attached to the U-bolt, and the lift bag floating above the container. The MATE ROV Competition will supply lift bags at the product demonstration station.

Once the lift bag is attached, companies must inflate the lift bag to recover the container. A [bicycle pump](#) will be provided at each product demonstration station. Airline tubing will be attached to the other end of the pump; ½-inch PVC pipe will be attached to bottom end of the airline tubing and act as a grab point. Companies must position the end of the airline tubing underneath the lift bag and pump air into the lift bag. Companies will receive 5 points when the lift bag is successfully inflated, and the container is at the surface. Successfully inflating the lift bag is defined as the lift bag breaking the surface with the container still attached.

Companies are allowed to provide their own manual pump (bicycle pump) and airline tubing to inflate the lift bag. A manual pump is required; companies may not use compressed air or an electrically powered pump to push air through the tubing and into the lift bag.

Once the container is at the surface, companies must return it to the surface, side of the pool. Companies will receive 5 points for successfully returning the container to the surface, side of the pool. Successfully returning the container to the surface, side of the pool is defined as the lift bag and the container removed from the water and placed on the pool deck.

### **Task 2.6 Monitor endangered Lake Titicaca giant frogs**

Companies must install a long-term camera to monitor the giant frogs into a designated area. The camera will be simulated by 1-inch PVC pipe attached to a 1/2-inch PVC pipe framework. The designated area will be a 40 cm square constructed from orange colored ½-inch PVC pipe. The camera will be located on the surface, side of the pool at the start of the product demonstration. Companies will receive 10 points when the camera is successfully installed into the designated area. Successfully installing the camera into the designated area is defined as the base of the camera framework completely within the pipe of the designated area. The base of the camera may not be on top of any portion of the ½-inch PVC pipe of the designated area.

## **TASK 3: MATE Floats! 2023**

### **UN Sustainable Development Goal:**

- #13 Climate Action

**This task involves the following steps:**

#### **3.1 MATE Floats!**

- **Adopt-a-float**
- **Recover the float**
  - **Simulate the float ascending to the surface by pulling a pin – 10 points**
  - **Recover the float to the surface side of the pool – 5 points**
- **Analyze float data**
  - **Graph water temperature versus depth – 15 points**

**Total points = 30 points**

### **Product Demonstration Notes:**

#### **Task 3.1 MATE Floats!**

Prior to the competition, SCOUT class companies are encouraged to [Adopt-a-Float](#). Companies will not receive points for adopting a float, but the MATE ROV Competition will use data from floats adopted by SCOUT class companies in this *MATE Floats! 2023* mission task. Companies that adopt a float should submit their float name and number, as well as their competition class, team name and regional they are planning to attend to the [2023 MATE ROV Competition NAVIGATOR/SCOUT Adopt-a-Float Information Submission Form](#). Adopted floats will be chosen at random and data collected by those floats will be used for this task. Companies whose floats are chosen will be recognized on the information sheet that displays the data.

Companies must recover the GO-BGC float. The float will be constructed from 1 ½-inch PVC pipe and will be positively buoyant. The float will be located on the bottom of the pool, attached to, and floating above a weighted PVC framework. Companies must pull a pin to release the float, simulating the float ascending from the bottom. The pin will be constructed from ½-inch PVC pipe. Companies will receive 10 points when they successfully pull the pin. Successfully pulling the pin is defined as the pin no longer in contact with the PVC pipe holding the GO-BGC float. After pulling the pin, companies may leave it on the bottom or return it to the surface. The pin is not considered debris.

Once companies have pulled the pin and the float has ascended to the surface, they must return the float to the surface, side of the pool. Companies will receive 5 points when they successfully remove the float from the water. Successfully removing the float is defined as the float completely out of the water and placed on the pool deck.

Once companies have successfully recovered the float at the surface, they must analyze the float data and create a graph plotting water temperature versus depth. A laminated sheet will be located inside the 1 ½-inch pipe of the float. This laminated data sheet will include water temperature and depth data, as well as the name and number of the specific GO-BGC float that collected the data (one of the floats adopted by a competition team). The data will consist of 10 water temperature readings (in °C) taken at 10 different depths (in meters). For example:

Float Name: Atlantis

Float Number: 5906508

Water Temperature °C	Depth (meters)
1.88	-1970
2.44	-1235
2.61	-937
2.86	-756
3.01	-552
3.88	-331
4.38	-176
4.55	-108
6.21	-71
6.21	-2

Companies will receive 15 points when they successfully create a graph. Successfully creating a graph is defined as plotting depth on the Y axis and temperature on the X-axis and showing the resulting graph to a



station judge. All dots should be linked by a line. Companies may use Excel or another computer programs to plot their data points or may plot the data points on graph paper. All graphs must have their axes labeled. An example of a graph plotting the above data points is represented below:

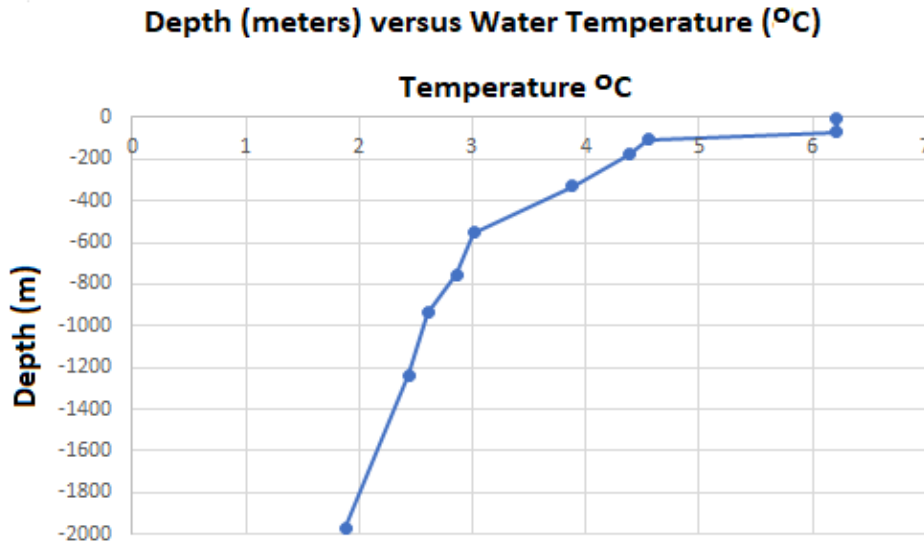

## PRODUCT DEMONSTRATION RESOURCES

[Coral Reef Fish Species Handbook](#)

A [blank graph for plotting water temperature versus depth](#) is available. Companies may plot this data on a computer or may use their own blank graph to plot the data points by hand.

## PRODUCT DEMONSTRATION RESPONSIBILITIES

Companies must design and bring any tools or devices to complete the required MATE product demonstration tasks.

## PART 2: PRODUCT DEMONSTRATION PROP BUILDING INSTRUCTIONS & PHOTOS



Obstacles



Creativity



Critical Thinking  
Problem Solving



Intellectual  
Development



System Design



Vehicle Design,  
Buoyancy, Propulsion



Sensors, Payload,  
Tools

The [product demonstration prop building instructions](#) will be released separately from this competition manual.

## PART 3: VEHICLE DESIGN & BUILDING SPECIFICATIONS



### 1.0 GENERAL

Questions about production demonstrations and design and building specifications should be sent to the [Competition Technical Manager](#). Question, answers, and official rulings will be posted on the [MATE ROV Competition Q&A and Official Ruling Document](#). This ensures that all companies can view the questions and answers and helps to avoid duplicate questions. That said, please make sure that your question(s) has not already been asked – and answered – before emailing. When emailing their question, companies should reference

- Any specific specification or rule (e.g. ELEC-002S)
- Competition class

[Your regional coordinator or your regional contest's website](#) will inform you of any specific requirements or changes for your regional.

### 2.0 SAFETY

Safety is the competition's primary concern and guiding principle. Any system that is deemed unsafe by competition officials will not be allowed to compete. If a safety concern is identified during the initial inspection, companies are permitted to modify their system and have it re-inspected. Companies are permitted to have their vehicle re-inspected twice. If a company fails to pass its third and final safety inspection, it is disqualified from the underwater competition portion of the event. There are NO APPEALS once an ROV has been disqualified.

#### **NOTE for 2023!!!**

MATE ROV Competition safety inspectors will be reinforcing the competition's emphasis on safety. Wiring discipline/workmanship and strain relief at both ends of the tether (ELEC-011S) will be areas of particular emphasis. **Companies that do not meet these safety standards will not be permitted to compete in the in-water events.** Additional examples of wiring workmanship will be included in the [MATE ROV Competition Safety Inspection Tutorial](#).

#### **Examples of safety violations from previous ROV competitions include:**

- The ROV does not use Anderson Powerpole connectors to attach to main power.

- No SID was provided at the safety check.
- The ROV does not have a main fuse.
- The SID did not show a main fuse.
- Sharp items, or potentially sharp items, (fishing hooks, glass bottles, Mercury thermometers) were included on the vehicle.
- The vehicle motors were not waterproofed.
- Propellers were not protected inside the framework or were not shrouded.

## 2.1 Safety inspection protocol

1. Before entering the water for practice or a product demonstration run, the ROV system must go through a safety inspection. Once a company successfully passes inspection, they will turn in their safety inspection sheet to the safety inspector and receive a Blue PASSED Card with their company number on it. Companies must present the Blue PASSED Card to the pool practice/product demonstration coordinator before their vehicles are permitted to enter the water.
2. Competition staff will conduct a safety inspection of the vehicle using the [safety inspection rubric](#).
3. If the safety inspector(s) identify a safety violation, companies will have the opportunity to address it. The pool practice or product demonstration run schedule will NOT change to allow companies more time.
4. If during the second safety review the
  - a. violation has not been properly addressed or
  - b. another violation is revealed
 companies will have ONE additional opportunity to address the issue.
5. If during the third safety inspection a violation still exists, safety inspectors will request that the Chief Judge(s) review the violation. If the Chief Judge(s) confirms the violation, companies will not be permitted to participate in the underwater product demonstration component of the competition. However, companies can still participate in the engineering and communication (technical documentation, engineering presentation, and marketing display) component.
6. Reminder: All companies must present the Blue PASSED Card to the pool practice or product demonstration judge before placing their vehicles in the water. In addition, product demonstration station judges and competition officials can pause or stop a product demonstration run at any time if they feel that there is a potential safety concern.

Your regional competition may use a system other than a Blue PASSED Card, but all companies must pass a safety inspection before entering the water. Contact [your regional coordinator or visit your regional contest's website](#) to determine if a Blue PASSED Card or another system will be used for safety verification.

### 2.1.1 System Interconnection Diagram (SID)

To pass the safety inspection, companies must provide a system interconnection diagram (SID) of their vehicle control system. An SID is an electrical diagram of their wiring, including their control box, motors, and any other electrical systems on their vehicle. The SID should separate and show what systems are on the surface and what systems are on the vehicle. The SID must not exceed one page in length. **The diagram MUST show**

an ROV system fuse. SIDs that do not show a fuse, utilizing an ANSI, NEMA or IEC symbol, with the size of the fuse marked, will not pass their safety check.

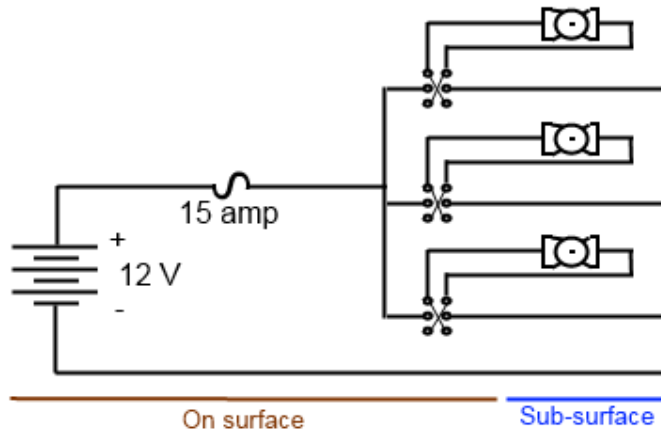

Diagram: An example of an acceptable SID.

Companies should create their own SID. Do not simply copy the above SID, or another SID produced by MATE, including those provided with kits purchased through the SeaMATE store. SIDs help to understand how electricity flows through your system and will provide a better understanding of ROV operations.

DOC-004: Any electrical diagram should use ANSI, NEMA, or IEC symbols as often as possible; it is required for the fuse. They should be neatly hand drawn or created using a CAD software program.

Item	ANSI	IEC
FUSE		

ANSI: American National Standards Institute

IEC: International Electrotechnical Commission

NEMA: National Electrical Manufacturers Association

Note: Companies that do not hand draw their SID may use free drawing software such as MS Paint or [OpenOffice](#) to create their diagrams.

## 2.2 Safety inspection completed

Companies must complete their safety inspection before entering the water for practice or a product demonstration run on the day of the competition.

## 3.0 SPECIFICATIONS

The ROV must meet the following requirements to compete in the event:

### 3.1. Operational

#### 3.1.1 Multiple Vehicles

OPER-001: MULTIPLE VEHICLES ARE NOT PERMITTED. Companies are required to design and build ONE ROV that can complete the necessary product demonstration tasks. All ROV components, including cameras and payload tools, must be connected to the ROV.

#### 3.1.2 Environmental

OPER-002: The ROV System must be able to function in fresh, chlorinated water with temperatures between 15°C and 30°C. The water should be considered conductive of electrical currents.

OPER-003: Visibility in the pool is unlimited. The pool will not be covered or purposefully darkened in any way. However, wind, divers, or ROVs may create ripples on the surface that affect visibility. Companies should plan accordingly.

OPER-004: There will be no water currents intentionally created. However, depending on the venue, pressurized pool filtration system outlets may cause unexpected currents.

**Note:** Contact [your regional coordinator or visit your regional contest's website](#) to learn more about the environmental operating conditions of the competition pool. Some pools may have sloping bottoms or other features that could affect your ROV's performance.

#### 3.1.3 Service Requirement

OPER-005: Companies shall provide a product demonstration team of at least 3 but no more than 4 people to operate the ROV on the pool deck. Companies may have more than 4 people, but only 4 company members are allowed on the pool deck to operate the vehicle.

#### 3.1.4 Maintenance

OPER-006: All work and system maintenance during operations shall be conducted by company personnel. Work of any kind must NOT be done by mentors or advisors.



## 3.2. Mechanical/Physical

### 3.2.1 Tether Length

MECH-001S: ROVs must be capable of operating in a maximum pool depth of 4 meters (13 feet). All underwater product demonstrations will take place within 6 meters (20 feet) from the side of the pool. Tether lengths should be calculated accordingly.

**Note:** Many SCOUT class competitions are held in water less than 4 meters deep. Contact [your regional coordinator or visit your regional contest's website](#) to determine the maximum depth of the SCOUT competition.

### 3.2.2 Vehicle Deployment and Recovery

MECH-002S: The product demonstration team must be able to carry the entire vehicle by hand. The crew must be able to hand launch and recover the ROV. No lifts or levers may be used to launch the ROV.

### 3.2.3 Propellers

MECH-003S: Propellers must be enclosed inside the frame of the ROV or shrouded. Companies that have propellers protruding outside of their frame will not pass the safety inspection and will not be allowed to compete.

## 3.3. Electrical

ELEC-001S: All power provided to your ROV system must be obtained from the MATE competition power supply. This is a singular point of connection; all power to your ROV must pass through the MATE-provided fuse on the supply AND the single fuse in your wiring.

ELEC-002S: MATE will provide a nominal 12VDC power source at the product demonstration station. This power source may be a battery or a power supply. Nominal voltage may be as high as 14.8 volts.

ELEC-003S: Voltage may never be increased above the nominal 12 volts anywhere in the ROV system.

### 3.3.1 Current

ELEC-004S: ROVs are limited to 15 amps.

The ROV **MUST** have a 15A maximum (or smaller) fuse in the positive power supply line within 30 cm of the positive Anderson Powerpole connector. The SID must show this fuse, using a proper fuse symbol, and include the amperage rating of the fuse.

### **NOTE for 2023!!!**

ELEC-005S: ROV systems are allowed only one replacement fuse during the product demonstration run. In the event that the ROV system blows the second fuse during the product demonstration, time will stop, the

product demonstration run will be over, and no additional points will be earned. Note: Companies must provide their own replacement fuses. MATE will not provide replacement fuses.

### 3.3.2 Power Connections

ELEC-006S: The MATE ROV Competition requires that all ROVs use Anderson Powerpole connections ([30 Amp Permanently Bonded Red/Black Anderson Powerpole Connectors | Powerwerx](#), [Power and Powerpole Assembly Kit \(suitable for Angelfish and Pufferfish\) – SeaMATE](#)). Power supply connections at all regional competitions will be red/black Anderson Powerpole Connectors.

Anderson Powerpole connections are two-piece connectors as shown in the picture below.



#### **NOTE for 2023!!!**

The red and black Powerpole pieces must attached together. Loose Powerpoles (those not attached together) will not pass safety inspection.

#### **Part specification and part numbers**

Anderson Powerpole – red and black connector with 30 amp contacts

Red is connected to power supply positive.

Black is connected to power supply negative.

Since Anderson sells the connectors in 2500 and 200 piece quantities, these connectors are available from distributors.

Powerpole Assembly Instructions

<http://www.powerwerx.com/assembly.asp>

<http://www.wb3w.net/powerpoleinst.htm> (see the section on using the TriCrimp tool)

YouTube video for Assembly

Part 1: [https://www.youtube.com/watch?v=8\\_DPPuQN8R4](https://www.youtube.com/watch?v=8_DPPuQN8R4)

Part 2: <https://www.youtube.com/watch?v=EsSsr2zGFqI>

ELEC-007S: The power supply may be located up to 2 meters from the station and may be located on either side of the station. MATE recommends a power cable long enough to reach the power supply up to 2 meters from your control system.

### 3.3.3 Exposed connections and disposable motors

ELEC-008S: All electrical components going into the water must be waterproofed. ROVs with electrical connections that are exposed to the water and not sealed will not be permitted to enter the pool. Disposable motors (motors with no waterproofing) are not permitted. Taping a connection with only electrical tape does not constitute a sealed connection. The process of sealing electrical connections must include methodologies such as, but not limited to, silicone RTV, hot melt glue, epoxy, self-vulcanizing tape, and enclosing the connection inside a housing.

### 3.4 Onboard Electrical Power

ELEC-009: Onboard electrical power is not allowed. All power for the vehicle must come down the tether. Batteries (9-volt, AAA, AA, etc.) are **NOT** allowed under any circumstances.

**NOTE:** *Water leaking into a closed battery container can result in the generation of hydrogen gas. This gas can build up inside a pressure housing and create an unsafe situation. For this reason, onboard batteries are NOT allowed under any circumstance. Any device that needs power must obtain that power directly from the ROV tether. For devices that operate at a voltage other than the tether voltage, an onboard ROV converter may be included. The converter must be sealed and not exposed to water. This rule includes commercial “watertight” battery containers; no battery of any type is permitted on any competition vehicle.*

### 3.5 Power Shutdown

ELEC-010S: Power shutdown: For safety purposes, any ROV that is disconnected from the surface power supply must stop functioning in less than 5 seconds.

### 3.6 Fluid Power

Any vehicle using fluid power must provide a fluid power diagram. Fluid power is defined as hydraulic pumps (water) or pneumatic pumps (air) on the vehicle or on the surface

FLUID-001S: Electrical pumps of any sort are NOT allowed. Companies may only use manual pumps (hand or foot pumps) to push fluids (including air) down the tether and to their vehicle.

FLUID-002S: Companies may only use WATER as their hydraulic fluid. Companies may only use AIR as their pneumatic fluid.

FLUID-003S: Companies may not use pressure accumulators. Pressure inside any container must never exceed the ambient pool pressure. If air is pumped into a container on the vehicle, that container must be open to the water. Vent holes on the container must be at least ¼-inch (6.35 mm) in diameter.

For example: A company wants to fill a PVC pipe container on the vehicle with air. Companies may only use a manual pump (hand/foot powered bicycle pump) to push air down to the vehicle. The company drills four ¼-inch holes in the bottom of the pipe. As they pump air into the container, it will displace the water out of the holes in the bottom of the pipe. However, the pressure inside the container can never get above the ambient pool pressure; excess air will come out the holes on the bottom of the pipe once all the water has been displaced.

### 3.7 Control Systems

ELEC-011S: Control systems must be built in a neat and workmanship like manner. Loose components and unsecured wires may not pass safety inspection. All wires entering and leaving the control system must have adequate strain relief and wire abrasion protection as the wires pass through the box.

### 3.8 Cameras and monitors

CAM-001: Cameras are not required in the SCOUT class. However, if a company chooses to use cameras on their ROV, they are limited to one video display screen. This monitor must be provided by the company; MATE will not provide a video display monitor for SCOUT companies.

CAM-002: All cameras and the one monitor MUST be powered from the MATE 12-volt supply. Companies may not plug cameras or the monitor into AC wall sockets. Companies may not use their own battery packs or USB to run cameras or monitors. NO EXCEPTIONS.

### 3.9 Lasers

SCOUT class companies may NOT use lasers on their vehicles.

## PART 4: COMPETITION RULES



Teamwork/  
Collaboration



Content  
Knowledge



Safety



Vehicle Design,  
Buoyancy, Propulsion

### 4.1 GENERAL

- All members of the company and their supporters must follow the safety regulations of the ROV competition, pool facility, and event venue.

- All company members and their supporters are expected to conduct themselves in a professional and responsible manner during the competition. Disrespectful behavior towards the judges, officials, pool staff, audience, or other companies will lead to penalty points or disqualification.
- Sabotaging, stealing, or pilfering equipment of other companies will lead to disqualification. Companies found cheating will also be disqualified.
- The MATE ROV competition is, at its core, designed to be an educational and inspirational event for **STUDENTS**. It is designed to challenge them to apply the physics, math, electronics, and engineering skills they are learning in the classroom to solving practical problems from the marine workplace. (See the [MATE Competition Philosophy](#).)

It is expected that all “adults” (non-students; e.g. teachers, mentors, parents) involved in the competition limit their input to educational and inspirational roles. Actual construction of the ROV (particularly in the complex electrical and software areas) must be completed by the students. Adults should teach and advise students about design, electronics, software, and construction, but not complete the work for the students. Throughout the process adults are encouraged to focus on benefits to the students from the process and not simply winning. If it becomes apparent that adults exercised more than an advisory role, judges reserve the right to deduct points or, in extreme cases, disqualify companies from the competition.

ALL work done on the vehicle must be conducted by company members. This includes any work done at home, at school, or during the MATE ROV competition. Teachers, mentors, parents, and non-competing students are not permitted to work on the ROVs. They may provide advisory input, but they may not work on the ROV directly. This includes writing or editing software code. All mechanical, electrical, and software modifications and/or repairs to the ROV must be completed by students.

With learning at its core, the MATE competition encourages students to utilize and build upon their skill sets to find creative solutions to designing and building their ROV. Students gain valuable skills and knowledge when creating a component from “scratch,” which is apparent to judges as they review the technical documentation and engineering presentation. However, as they move through the process of analyzing their designs and identifying building materials, students may decide to either build a component from “scratch” or purchase it from a commercial vendor.\*\*\* So, while original solutions are encouraged, the use of commercial components is acceptable, provided 1) that the components adhere to the design and building as well as safety specifications for the particular competition class and 2) more importantly, that the students can provide a reasonable, logical explanation for buying versus building.

The competition scoring rubrics are designed to reflect this; points are awarded based on students’ abilities to explain and justify how all of the components and systems work together as an integrated ROV, regardless if they purchased them, pulled them from public libraries, or made them themselves.

\*\*\*Note “commercial vendor” includes the [SeaMATE store](#) and other competition programs that sell educational robotics kits. SeaMATE kits were created to remove barriers to participation for teachers and schools unable to easily 1) find parts and materials and 2) set up accounts with multiple vendors. The kits are part of a larger educational package offered by SeaMATE that includes curriculum materials, videos, and other resources to support and enhance learning. And learning is what students who use SeaMATE (or other) kits will be expected to demonstrate during and through the [ENGINEERING & COMMUNICATION](#) components.

It should be noted that purchasing and competing with complete, assembled, commercial ROVs is not permitted.

## 4.2 PROCEDURAL

- Companies must compete during their assigned time slots. Your company is **NOT** permitted to switch time slots with another company. Failure to show for your scheduled product demonstration or for your company’s engineering presentation will result in “no score” for that particular competition category. **No exceptions.** Assigned time slots will be sent out in advance so that any scheduling concerns can be addressed prior to the event. Contact [your regional coordinator](#) at least four weeks before the competition if you know you have a scheduling concern.
- While there is no limit to the number of students who can compete as part of a company, **the product demonstration team (aka demo team) is limited to four students.** The demo team is defined as the team of students who operate the vehicle and its associated equipment during the product demonstration. The product demonstration is held at a “product demonstration station.” Only four students will be allowed to enter the product demonstration station, launch, pilot, and perform the tasks. Instructors, mentors, and/or non-student members cannot participate as part of the demo team. If a regional offers two product demonstration attempts, **companies may alternate students on the demo team for the two product demonstrations. See below for additional information about the number of attempts.** (All members of the company should participate in the engineering and communication components; see [ENGINEERING & COMMUNICATION](#) for more information.)
- Only the demo team members and judges are allowed at the product demonstration station during the product demonstration, which includes the set-up and demobilization periods. Other members of the company, instructors, mentors, audience members, and observers (press or special invited guests) must remain outside the product demonstration station or in designated viewing areas.
- Instructors, mentors, parents, and “fans” are **NOT** permitted at the safety inspection stations or repair tables. Two warnings will be issued before individuals not following this rule will be asked to leave the venue.

- In addition, instructors, mentors, parents, and fans are **NOT** permitted to work on the ROV. Individuals who are seen working on the ROV who are not student company members will be issued a warning. Two warnings will be issued before individuals not following this rule will be asked to leave the venue. If companies choose to take their ROVs off the competition grounds for maintenance and repair, they are expected to observe this rule in the interests of the spirit of the competition.
- Video devices may be used to record the underwater activities for entertainment and learning purposes **only**. Video will not be used as an instant replay to review judges' decisions or to challenge product demonstration timing.
- Companies will compete in ONE product demonstration that consists of three distinct tasks. Companies may get up to **TWO** attempts to complete each product demonstrations. If that is the case, the **higher** of the two scores will be added to the engineering and communication score to determine the total, overall score for the competition.

In general, the product demonstration time consists of a 3-minute set-up period, a 10-minute performance period, and a 2-minute demobilization period. If the demo team and all of their equipment are not out of the product demonstration station at the end of the 2-minute demobilization period, the company will be **penalized 1 point for each additional minute**.

**Note:** Regional contests may or may NOT offer companies two attempts at the product demonstration tasks. In addition, the product demonstration time frames for set-up, performance period, and demobilization may be different at your regional contest. Contact [your regional coordinator or visit your regional contest's website](#) for more information.

- Manipulating the tether to free it from underwater obstacles is permitted. Pulling on the tether to speed up the recovery of items or to return your vehicle more quickly to the surface is not permitted and will result in penalty points. Judges will issue one warning if tether pulling occurs. Each future infraction will result in **5** points deducted from the final product demonstration score.
- If your vehicle is completely disabled and/or its tether tangled and unable to free itself from the underwater environment, SCUBA divers can be called in to assist. However, the product demonstration time will NOT stop and **5** points will be deducted from the final product demonstration score.

Diver assistance may not be available at your regional competition. Contact [your regional coordinator or visit your regional contest's website](#) to determine if diver assistance will be available at your regional competition.

- No demo team member shall enter the water to complete an object recovery. Only arms and hands are allowed into the pool to retrieve an object or to retrieve the vehicle. Companies will be disqualified or penalized depending on the severity of the infraction.



- Communication using cell phones, text messaging, and online social media tools such as Skype, Facebook, Twitter, instant messaging, etc. is NOT permitted during the product demonstration, either between the demo team members at poolside or between any demo team member and anyone outside of the product demonstration station.
- **Product demonstration judges and other competition officials will only communicate with students.** Judges and officials will NOT communicate with mentors, parents, or other non-student members regarding product demonstration information, challenges, or other issues except during pre- and post-competition briefing sessions.

Companies that want to issue a challenge during the product demonstration run should immediately communicate this challenge to the product demonstration judges. The judges will discuss and attempt to resolve the issue. If a decision cannot be made, the product demonstration judges will consult with the head judges, competition technical manager, and/or the competition coordinator to resolve the issue.

### 4.3 DESIGN & SAFETY CONSIDERATIONS

- The competition coordinators and host venues stress the importance of safety practices and procedures to all companies. The score sheets and rubrics will reflect the MATE ROV Competition's efforts to encourage and reward companies that demonstrate exceptional safety practices and procedures.
- **ALL ROVS MUST PASS A SAFETY INSPECTION CONDUCTED BY COMPETITION OFFICIALS PRIOR TO ENTERING THE POOL.** These inspections will be conducted topside to ensure that ROV systems meet the design and building specifications and do not pose a risk to the integrity of the event venue. See [VEHICLE DESIGN & BUILDING SPECIFICATIONS](#) for additional information.

**ROV MOTORS MUST BE WATERPROOFED!** No exceptions. You may use already waterproofed motors (bilge pump motors, etc.) or you may choose to waterproof small electrical motors.

- Propellers must be enclosed inside the frame of the ROV or shrouded. **Companies that have propellers protruding outside of their frame will not pass the safety inspection and will not be allowed to compete.**
- Cameras and monitors are permitted but aren't needed as companies are allowed to look into the pool to pilot the ROV. If your company chooses to use a camera(s), the camera(s) and monitor must be powered off of the 12-volt battery or power supply provided by the contest organizers. **NO AC POWER IS PERMITTED WHATSOEVER.** In other words, you can't plug your ROV into a wall socket!

- Radio transmitters that operate on a separate battery are permitted. No batteries are permitted to be in or on the water. No exceptions. Note that although wireless controllers are allowed, MATE is not responsible for wireless interference. Adjacent wireless controllers with a battery that has a higher charge may “hijack” control signals. MATE will not stop the clock to resolve wireless control issues under any circumstance. Companies deciding to utilize wireless controllers do so at their own risk.
- Safety must also be a priority when operating your ROV poolside. Keep an eye out for tripping hazards. Make sure that your connections to the battery or power supply are not lying in pools of water on the deck. During your product demonstration, be sure to secure any equipment so that it does not fall, damage the deck, or cause injury.
- Loose fitting clothing, jewelry, and long hair could all become safety issues. Consider securing long shirts or baggy pants, removing jewelry, and tying back long hair when working on or operating your ROV.
- ROVs may be constructed out of materials of your company’s choice, provided they meet the design and building specifications and safety regulations. Warning labels should be posted on potentially hazardous components of your ROV system.
- **Closed-toed shoes are required on the pool deck and anytime you are working on your ROV.** Safety glasses or goggles should be worn when working on your ROV.
- Personal flotation devices (PFDs) may be required when launching and recovering your vehicles. Contact [your regional coordinator or visit your regional contest’s website](#) to determine whether this is a requirement at your regional event. If PFDs are required, they will be provided by the regional coordinator.

## PART 5: ENGINEERING & COMMUNICATION



MATE has created an ROV Competition [Marketing Kit](#) that includes logos and guidelines for their use.

The ability to communicate information about your vehicle and the design and building process is equally as important as how well your vehicle performs. Strong communication skills are an essential part of good business practices and one of the most in-demand skills in the constantly evolving, ever-changing workplace.

To emphasize this point, the competition requires the following five engineering and communication components:

- Company spec sheet
- Technical (written) Documentation (Examples of spec sheets and technical documentation from previous competitions can be found in the [MATE ROV Competition Archives](#).)
- Engineering (oral) presentation (Examples of engineering presentations can be found on [MATE's Vimeo channel](#).)
- Marketing display
- Corporate Responsibility (OPTIONAL)

**NOTE: Regional contests may not require all of the Engineering & Communication components.** Contact [your regional coordinator or visit your regional contest's website](#) for more information.

See the [TIPS FOR EFFECTIVE WRITTEN AND ORAL COMMUNICATION](#) for additional information.

***NOTE for 2023!!!***

Your company should refer directly to the scoring rubrics posted under [Scoring](#) for details on what is required for your technical documentation, engineering presentation, and marketing display. The judges will use the rubrics to evaluate and score these engineering and communication components.

## 5.1 COMPANY SPEC SHEET

The purpose of the company spec sheet is to provide the judges with a “snapshot” of your company. It includes basic information about your company and vehicle.

Company spec sheets will be reviewed by MATE competition coordinators. Companies will receive up to 20 points for submitting a spec sheet that is **one page** in length, follows the file size and naming specifications, and contains **all** of the following information:

### COMPANY SPECS

- **Company and school, club, or community organization name**
- **Home state and/or country**
- **Distance required to travel to the world championship**
- **History of MATE ROV competition participation.** Be sure to specify if your company and/or the members of your company are “new” or “returning.”
- **Company photo and caption indicating members' names and roles (e.g. CEO, CFO, Design Engineer, Pilot, etc.).** This photo should include all of the members of your company.

- **Range of grade/college levels represented by the members of your company**

#### **ROV SPECS**

- **ROV name** if applicable
- **Total cost.** You must include the approximate cost of any donated items.
- **Size and weight measurements**
- **Total student-hours to design and build.** This should include the number of hours that each and every member of the company worked on the vehicle.
- **Safety features**
- **Special features**
- **Photo of the vehicle**

**REMINDER!!!** If all of the above information is included, the specifications for length, size, and naming conventions are followed carefully, and the document is submitted on time, this is an “easy” 20 points! You can find the company spec sheet scoring rubric posted [here](#).

## **5.2 TECHNICAL DOCUMENTATION**

The purpose of the technical documentation is to challenge you to communicate information using clear and concise text along with graphics, illustrations, and data that add to and complement (and not distract from) the information. Your company must organize and present the information in a way that is logical and complete. The document should focus on the technical and safety aspects of your ROV/ROV systems, the design rationale behind your engineering decisions, and a critical analysis of testing and troubleshooting done on the vehicle. You should consider this document a reference for both judges and future team members (part of the company’s institutional knowledge).

Your company’s technical documentation will be reviewed and evaluated by a panel of working professionals – individuals who represent science, exploration, government, and industry.

Each judge on the panel will award a score (50 points max). Judges’ scores and comments will be returned to you shortly after the event.

**NOTE: The judges will not review and rescore revised versions of your technical documentation during the competition.**

**Use the technical documentation scoring rubric posted [here](#) as the guideline for the required components for the technical documentation. This rubric will be posted by March 1, 2023. In the meantime, companies may refer to the previous year’s rubrics for a general idea of the categories and points.**

### 5.3 ENGINEERING PRESENTATION

The purpose of the engineering presentation is to challenge you to communicate information with words and “props” (i.e., the ROV). Your company must organize and present the information in a way that is logical and covers the development and testing of your ROVs and the formation and development of their team. The presentation should be delivered as a “technical brief.” The presentation is the opportunity your company has to 1) communicate directly and in person your critical thinking, creativity, and engineering reasoning and 2) demonstrate your individual and collaborative contributions to the creation of the vehicle.

During the competition, your company will have 5-10 minutes deliver your presentation to a panel of working professionals – individuals who represent science, exploration, government, and industry. After the presentation, the judges will take 5-10 minutes to ask the members of your company questions about your ROV. The judges will evaluate both your presentation and responses to their questions. Each judge on the panel will award a score (50 points max). Judges’ scores and comments will be returned to you shortly after the event.

**All student members of your company must be prepared to participate in the presentation and question and answer (Q&A) period.** You are required to have your ROV with you. During the Q&A, all members of the company should be prepared to answer. However, if one student is better able to answer a specific question, the others may pass the question to that student to answer. For example, if a judge calls on the pilot to answer a question about the tether, the pilot can respond by informing the judge that the tether manager was the lead on that system and allow the tether manager to answer without penalty or loss of points.

**NOTE:** The engineering presentation is designed to be a face-to-face interaction where students and representatives from industry become engaged in conversation. MATE will not provide audio visual aids, such as slide projectors, computer projection screens, white boards, etc.; however, you are welcome to distribute handouts to help judges better understand the information that you are presenting. Electronic forms of presentation (e.g. PowerPoint or Keynote slides) **are NOT permitted.**

**Instructors, mentors, family members, friends, and members of other companies are permitted to attend.** However, we ask that those in attendance be respectful and courteous throughout the presentation and follow-up question and answer period. Be mindful that this presentation may be a stressful time for the students. If the room becomes crowded or the spectators become distracting, it is up to the judges’ discretion to request that some or all spectators leave the presentation. **While they are permitted to attend, instructors and mentors are not allowed to participate.**

**Use the engineering presentation scoring rubric posted [here](#) as the guideline for the required components for the engineering presentation. This rubric will be posted by March 1, 2023. In the meantime, companies may refer to the previous year’s rubrics for a general idea of the categories and points.** Judges may ask questions regarding any of these topics not covered in the presentation as well as other questions about the vehicle, the mission theme, or the company.

**Preparing for your engineering presentation and Q&A**  
2023 SCOUT CLASS

- Make sure that every member of your company has a good, general working knowledge of your vehicle, even though they may have specialized in one specific aspect of its design and construction.
- Encourage each member of your company to keep a project notebook. Before the competition, set up a time where you compare notebooks. One member might have written more information about your ROV's electrical system, while another might have included details about buoyancy that others forgot. This exercise will help to refresh everyone's memory about the design and building process. If your company submitted technical documentation, make sure that all company members have read and are familiar with it. This exercise will help to familiarize everyone with all aspects of the project.
- Generally, you will have more to say about your ROV than can be presented in 5-10 minutes. That is why it is critical to organize your material and practice communicating it. However, avoid coming across as having memorized your presentation verbatim. Judges want to see that you are prepared and understand the information, not that you can simply regurgitate a rehearsed speech from memory. Ask your instructors or mentors to give you feedback.

### **Other important items**

- If during the engineering presentation it becomes apparent that instructors, mentors, and other adults associated with your company exercised more than an advisory role, judges reserve the right to deduct points or, in extreme cases, disqualify companies.

## **5.4 MARKETING DISPLAY**

The purpose of the marketing display is to challenge you to present technical information in a way that is appealing to and understood by a non-technical audience. It is the promotional piece – you must not only present information about your ROV and your company, but you must also use graphics and design to publicize and “sell” (convince viewers of their value and excellence) your products and people.

During the competition, your company's display will be evaluated and scored by a completely different group of working professionals – individuals who will represent science, business, government, industry, and education/outreach.

While some judges will have a technical background, others will have a communications, marketing, or public relations background. In addition, there will be visitors to the competition who may not completely understand what an ROV is or how it is used. Think of these visitors as potential future clients who may authorize funding for your work but have a limited understanding of the technology (i.e., you need to explain your technology, the tasks at hand, and “sell” them on YOUR products and services). Design your display to communicate to this type of audience.

Each judge will award a score (50 points max). Judges' scores and comments will be returned to you shortly after the event.

Each company will have a space approximately 3-feet x 3-feet for its display. Depending on your regional, tables may or may not be provided. Contact [your regional coordinator or visit your regional contest's website](#)

for more information.

**Use the marketing display scoring rubric posted [here](#) as the guideline for the required components for the marketing display. This rubric will be posted by March 1, 2023. In the meantime, companies may refer to the previous year’s rubrics for a general idea of the categories and points.**

**Creating an effective marketing display:**

- Address the theme and make real-world connections.
- Reflect your company’s personality and mindset.
- Make key points and be concise.
- Keep the general public in mind.
- Make sure to label any and all figures, graphs, diagrams, and photographs and credit the source.
- Maximize the use of the 36” by 48” display space.
- Make sure that it is both informational and aesthetically pleasing.

**Note:** “Accessories” such as video footage, PowerPoint slide presentations running on laptop computers, video projections, etc. are permitted but should be used with discretion. Remember that the judges will have a limited amount of time to evaluate your marketing display and may find excessive use of audio or video presentations distracting.

However, if you do make a video of your ROV building or competition experience, please submit information about it to the [MATE ROV Competition officials](#) so that it can be shared via MATE’s YouTube and Vimeo channels.

## 5.5 CORPORATE RESPONSIBILITY

The MATE ROV Competition uses underwater robotics to inspire and encourage students’ interest in STEM (science, technology, engineering, and math) education and careers. Recognizing that the students who participate in MATE competitions are powerful ambassadors for the program as well as effective leaders in raising awareness of important issues and bringing about positive change, companies have the opportunity to earn up to 20 points for “corporate responsibility.”

Corporate responsibility includes, but is not limited to, the following:

- **Mentoring** consists of, for example, providing guidance to other students in your area who are designing and building an ROV for the competition or a science or other project.
- **Engaging the community** includes demonstrating your ROV and sharing information about your company at festivities and other community-wide events. Presenting to a Rotary Club or your school districts board of directors are other examples.
- **Media outreach** consists of:
  - Developing a list local media contacts
  - Writing a press release about your participation in the MATE ROV competition
  - Distributing it to your media contacts



- Following up with your media contacts to see if they're interested in your company and its ROV
- Compiling a summary of results

Here are some [general guidelines](#) for working with the media. They are specific to the World Championship but can be easily modified for regional events.

- **Raising awareness of environmental, social, and governance (ESG) issues. Just look at this year's theme and product demonstration tasks for ideas – from installing marine renewable energy to reduce carbon emissions to helping and healing the environment to monitoring the health of the oceans.**
- Corporate responsibility efforts will be reviewed by competition coordinators and awarded 0 to 20 bonus points, depending on the number and scope of the outreach and awareness activity(s), i.e., the number of other students or members of the community engaged, the number of mentoring sessions, etc.

Make sure to include the following information in your write-up:

- Type of activity (e.g. mentoring, exhibiting at a community event, raising awareness)
- Locations, dates, and the amount of time spent on the activity
- Number of students or community members (if a large event, this can be an approximate) involved
- Description of your actions, outcomes, and other information that helps to demonstrate the quality of your time and efforts
- For media outreach, please submit a copy of your press release, a copy of your media contacts list, and a summary of news articles, TV or radio coverage, etc. that your company received. Include copies of articles and URLs and list any television or radio coverage. Be sure to include name of outlet, date, and a summary of the coverage.

### TIPS FOR EFFECTIVE WRITTEN AND ORAL COMMUNICATION

Communicating ideas about how to solve a problem and evaluating those ideas against alternative ideas is a critical skill for anyone entering the workplace. It is a skill that is directly linked to decision making about whether or not to hire (or fund) us and our ability to have a say in the work that we do.

The key to a successful technical documentation and engineering presentation is the way that critical thinking and engineering reasoning are communicated. You can think of the process as technical "storytelling."

Technical storytelling includes the use of text, images, schematics, and data to communicate the "story" of how your company brainstormed and evaluated ideas to come up with your solution (e.g. ROV, payload tools, and operational strategies) to the problem at hand (product demonstration tasks). It also involves organizing information to efficiently present your work and justify why you did what you did.

However, you should choose details with care. Each detail should help to answer the question "why is what you did the best solution for your company and for this competition?" Describe why a component in the

system is important and how you chose it. Include specifications or dimensions only if they help to explain the “why” and “how” you made choices. Keep in mind that a mechanical drawing with dimensions can replace a lot of text and in many cases do a better job telling details of the story than text.

That said, if something is hard to describe clearly and completely with two to three sentences, consider whether using an image may help. A good technical document balances text and images to provide lots of information in a concise way, which helps give readers a detailed understanding while being quick and easy to read. Remember that your reader is new to your design and needs to understand both what your design is and the process you used to get there. Present text and images in a logical order that helps readers follow your design and building process and results.

Maintaining a project notebook is a good business practice that will help to capture ideas and document your company’s progress – including your research, designs, trade studies, experiments, data, vehicle specifications, testing, expenditures, and donations. The notebook is also a place to keep track of your company member’s contributions (time, support, etc.).

Along with your notebook, here are some items to consider as you prepare to tell your story:

- What was your company’s “work breakdown structure” (tasks, time, and people)?
- What were the greatest constraints (schedule, budget, equipment, labor, logistics, etc.) on your design process?
- How did the product demonstration tasks and rules influence your design and decisions?
- What process did you use to evaluate different design solutions?
- What were the most important design decisions you made and why?
- How did you arrive at your final power budget? What trade-offs, if any, did you have to make and why?
- How do you calibrate your sensors?
- If your vehicle uses software, where does the code execute? Describe the flow and format of the data.
- Did you have a major troubleshooting experience? Any problem or procedure that takes more than 20 minutes to figure out is worth understanding and writing down.

## PART 6: DOCUMENTATION



Communication



Autonomy



Obstacles



Project Management

Companies are required to submit a system interconnection diagram (SID) of their vehicle control system. Your regional may also require you to submit technical documentation and a company spec sheet.

Contact [your regional coordinator or visit your regional contest's website](#) to determine what documentation must be submitted for your regional and the date it is due.

DOC-001: Technical documentation: A technical document or engineering notebook about your vehicle that will be reviewed by a panel of judges. See the [technical documentation](#) section for more information on the contents required for the technical documentation.

DOC-002: Company spec sheet: A one page document that provides a snapshot of your company and ROV. See the [company spec sheet](#) section for more information on the requirement for the company spec sheet.

DOC-003: SID Electrical: Companies must provide a [system interconnection diagram \(SID\)](#) of their vehicle control system during their safety inspection.

DOC-004: Fluid power SID: Companies using fluid power (hydraulics or pneumatics) must provide a fluid power diagram. The diagram should separate and show what systems are on the surface and what systems are on the vehicle. A fluid power SID for simple syringe hydraulics would consist of a syringe box on the surface connecting to a syringe box on the vehicle.

The fluid power SID can be incorporated into the Electrical SID or can be a separate, one page document.

DOC-005: Documents may be due before the competition or the day of the competition. Regardless, companies MUST bring a SID of their ROV systems in order to pass the safety inspection!

NOTE: By submitting your documentation, you are giving the MATE ROV Competition permission to publish these documents on its web site.

## 6.2 KEY DEADLINES

Contact [your regional coordinator or visit your regional contest's website](#) to determine the key deadlines for your regional competition.