

NAVIGATOR & SCOUT Class Safety Inspection Tutorial

This tutorial goes through the safety practices required by the MATE ROV Competition. It covers:

- Initial Safety Inspection (if required)
- Onsite Safety Inspection
- Examples and photographs of what will and will not pass safety inspection

SCOUT & NAVIGATOR Class Safety Inspection Sheet Tutorial

DOCUMENTATION REQUIRED

DOC-001: Companies must provide a system interconnection diagram (SID) of their vehicle control system. An SID is an electrical diagram of their wiring, including their control box, motors, and any other electrical systems on their vehicle. The SID should separate and show what systems are on the surface and what systems are on the vehicle.

The SID is the starting point for Scout & Navigator Safety.

Companies should be aware of safety and every team is required to submit a SID.

If not required early by the regional, a SID must be present for the on-site safety inspection.

DOC-002: Any electrical diagram should use ANSI, NEMA, or IEC symbols. They should be neatly hand drawn or created using a CAD software program.

AN EXAMPLE OF A SID IS SHOWN IN THE COMPETITION MANUAL.

DOC-003: Companies using fluid power must submit a fluid interconnection diagram (Fluid SID) of their system. Companies using syringe hydraulics only need a simple diagram, and could include it on their electrical SID. **NAVIGATOR companies using powered pumps or compressors MUST include a full fluid SID.**

SCOUT & NAVIGATOR Class Safety Inspection Sheet Tutorial

Initial Safety Inspection & Documentation Review Score Sheet

Company Name:			Company Number:		
MATE ROV Competition					
NAVIGATOR/SCOUT CLASS INITIAL SAFETY AND DOCUMENTATION REVIEW					
Submission is on time, within the given size limit, uses the proper naming convention, is a PDF file, and is submitted with the other documents.					
1	0	All documentation complies with submission guidelines			
1	0	SID is 1 page in length and differentiates between above and below surface components			
1	0	SID shows a fuse and fuse uses a proper IEC, NEMA, or ANSI symbol			
1	0	SID shows fluid power components or company states fluid power is not used on ROV			
1	0	ROV uses Anderson powerpole connectors and fuse is within 30 cm of connection to power			
1	0	All components are securely attached to ROV			
1	0	Tether is properly secured with strain relief at both ends			
1	0	Motors are waterproofed and propellers are shrouded or completely inside the ROV frame			
1	0	No sharp or hazardous items			
1	0	Camera operates of 12VDC supply or a camera is NOT used on the vehicle.			
TOTAL POINTS:					

Initial Safety Review

Simple Check Points

- Turned in on time?
- Documentation correct format and size?
- SID neatly done and includes industry standard fuse symbol?
- Any Fluid Power?
- Any issues seen will be listed.

*The Initial Safety Inspection and Documentation Review score sheets will only be used if your regional requires prior submission of documents. Check your regional website's Competition Information document or contact your regional coordinator to determine whether documentation must be submitted prior to competition day.

SCOUT & NAVIGATOR Class Safety Inspection Sheet Tutorial

Onsite Safety Inspection

Safety is the competition's primary concern and guiding principle. Any system that is considered unsafe by competition officials will not be allowed to compete.

If a concern is found during the first safety inspection, companies are permitted to attempt to correct it and have their ROV re-inspected. However, the competition schedule will NOT change to allow companies more time.

Companies are allowed to have their vehicle re-inspected twice. If a company fails to pass its third and final safety inspection, it is disqualified from the underwater competition portion of the event. There are NO APPEALS once your ROV has been disqualified.

SCOUT & NAVIGATOR Class Safety Inspection Sheet Tutorial

Onsite Safety Inspection

Examples of safety violations from previous ROV competitions include:

- The ROV does not use Anderson Powerpole connectors to attach to main power.
- No SID was provided at the safety check.
- The SID did not show a main fuse.
- The ROV used pneumatics, but the technical documentation did not include a pneumatics diagram (fluid SID).
- Sharp items, or potentially sharp items, (fishing hooks, glass bottles) were included on the vehicle.
- The vehicle motors were not waterproofed.
- Propellers were not protected inside the framework or not shrouded.
- Camera did not operate off the 12-volt MATE power supply.

SCOUT & NAVIGATOR Class Safety Inspection Protocol

Onsite Safety Inspection

Competition staff will conduct a safety inspection of the vehicle using the safety inspection rubric.

If the safety inspector(s) identify a safety violation, companies will have the opportunity to address it. The pool practice or product demonstration run schedule will **NOT** change to allow companies more time.

If during the second safety review the

- a. violation has not been properly addressed or
- b. another violation is revealed

companies will have **ONE** additional opportunity to address the issue.

SCOUT SAFETY INSPECTION SHEET

Company Name: _____ Company Number: _____

**MATE ROV COMPETITION
SCOUT CLASS SAFETY INSPECTION CHECKLIST**

Companies must bring this check list, the ROV, tether, surface controls, and any other item used in the deployment and operation of the ROV; they will all be inspected as part of the safety check. In addition, the SID, must be made available to the Safety Inspectors during the inspection process.

<p>1.0 Initial Safety Inspection</p> <p>Fluid power approved? Fluid power used? If yes to both, see Section 4.0 Pneumatics / Hydraulics</p> <p>2.0 ROV Physical</p> <p>All items attached to ROV are secure. Hazardous items are identified and protection provided. ALL propellers are completely shrouded or are enclosed inside the frame of the ROV. No sharp edges or elements of the ROV design that could cause injury to personnel or damage the pool surface.</p> <p>3.0 ROV Electrical</p> <p>Tether is properly secured at the ROV. No exposed motors. Brushless motors are considered exposed unless electrically sealed after purchase. Companies should provide proof of sealing procedure. No exposed copper or bare wire. All wiring securely fastened and properly sealed.* Any splices in tether are properly sealed.*</p> <p>3.1 Surface Controls Electrical & Physical</p> <p>Single attachment point to the power source. Anderson powerpole attachment to power source. 15 amp (or less) single inline fuse within 30 cm of power supply attachment point. The surface control station is built in a neat and workmanship like manner. No loose components or unsecured wires. All electrical components are covered inside an enclosure. No exposed copper or bare wire. If used, 120VAC wiring is separated from the DC wiring. All wires entering and leaving the surface control station must have adequate strain relief and wire abrasion protection as the wires pass through the enclosure. No AC power sources Cables to operate off the MATE 12VDC power supply through the single attachment point to the power source.</p> <p>* Properly sealed means that the wires cannot be exposed to water. Tape only sealing will allow the conduction of electricity through water.</p> <p>At minimum, joints must be soldered, sealed with a proper waterproof sealant, and covered in tape or shrink wrap. For in water taping, silicone self-vulcanizing tape is preferred over thermoplastic tape. Cables with exposed male connections on both ends are not allowed.</p>	<p>4.0 Pneumatic / Hydraulic (if applicable)</p> <p>Pneumatic or hydraulic diagram (SID) present. Uses air for pneumatics or water for hydraulics. No electrical pumps allowed. Manual (and or foot pumps only!) No pressure accumulators (pressure inside a container should never be higher than ambient pressure). Any container that air is being pumped into is vented to the pool with vent holes at least 1/4-inch (6.35 mm) diameter.</p> <p>5.0 Lasers</p> <p>No lasers present (lasers are not allowed in the NAVIGATOR class).</p>
--	---

SAFETY INSPECTION #1 **PASSED: 10 POINTS**

Failed: Items to correct noted on rear of this sheet.

SAFETY INSPECTION #2 **PASSED: 10 POINTS**

Failed: Items to correct noted on rear of this sheet.

SAFETY INSPECTION #3 **PASSED: 10 POINTS**

Failed: Reason/ details are noted on rear of this sheet.

Total Safety Points

On Site Inspection

0 or 10 points

Inspection #1: Items to address **Judge:** _____

Inspection #2: Items to address **Judge:** _____

Inspection #3: Reason **Judge:** _____

NAVIGATOR SAFETY INSPECTION SHEET

Company Name: _____ Company Number: _____

**MATE ROV COMPETITION
NAVIGATOR CLASS SAFETY INSPECTION CHECKLIST**

Companies must bring this check list, the ROV, tether, surface controls, and any other item used in the deployment and operation of the ROV; they will all be inspected as part of the safety check. In addition, the SID, must be made available to the Safety Inspectors during the inspection process.

<p>1.0 Initial Safety Inspection</p> <p>Fluid power approved? Fluid power used? If yes to both, see Section 4.0 Pneumatics / Hydraulics</p> <p>2.0 ROV Physical</p> <p>All items attached to ROV are secure. Hazardous items are identified and protection provided. ALL propellers are completely shrouded or are enclosed inside the frame of the ROV. No sharp edges or elements of the ROV design that could cause injury to personnel or damage the pool surface.</p> <p>3.0 ROV Electrical</p> <p>Tether is properly secured at the ROV. No exposed motors. Brushless motors are considered exposed unless electrically sealed after purchase. Companies should provide proof of sealing procedure. No exposed copper or bare wire. All wiring securely fastened and properly sealed.* Any splices in tether are properly sealed.*</p> <p>3.1 Surface Controls Electrical & Physical</p> <p>Single attachment point to the power source. Anderson powerspole attachment to power source. 15 amp (or less) single inline fuse within 30 cm of power supply attachment point.</p> <p>The surface control station is built in a neat and workmanship like manner. No loose components or unsecured wires. All electrical components are covered inside an enclosure. No exposed copper or bare wire. If used, 120VAC wiring is separated from the DC wiring. If used, 120VAC wiring must be clearly identified from the DC and control voltages with signage and/or wire color schemes. If the color scheme is used, a key must be provided for identification. All wires entering and leaving the surface control station must have adequate strain relief and wire abrasion protection as the wires pass through the enclosure. Camera as operate off the MATE 12VDC power supply through the single attachment point to the power source.</p> <p>* Properly sealed means that the wires cannot be exposed to water. Tape only sealing will allow the conduction of electricity through water.</p> <p>At minimum, joints must be soldered, sealed with a proper waterproof sealant, and covered in tape or shrink wrap. For in water taping, silicone self-vulcanizing tape is preferred over thermoplastic tape. Cables with exposed male connections on both ends are not allowed.</p>	<p>4.0. Pneumatic / Hydraulic (if applicable)</p> <p>Passed fluid power quiz. Pneumatic or hydraulic diagram (SID) present. Water is used as the hydraulic fluid. All pressure lines have a minimum pressure rating of 100 PSI (pneumatic) or 300 PSI (hydraulic) stamped on the line or verified with specifications. Valves meet the minimum pressure rating of 100 PSI (pneumatic) or 300 PSI (hydraulic)</p> <p>Attachment to the pressure source is secure. Pressure is regulated to: 40 PSI max for pneumatics 150 PSI max for hydraulics Pressure vessels have a stamped pressure rating or verification by inspection. Pressure vessels have a current inspection sticker. Pressure vessels can be secured on the pool deck. Company fabricated pressure accumulator test results are provided (if used). No hydraulic fluids are leaking. Pneumatics utilize compressed air or inert gas.</p> <p>5.0 Lasers</p> <p>No lasers present (lasers are not allowed in the NAVIGATOR class).</p>
---	--

SAFETY INSPECTION #1 **PASSED: 10 POINTS**

Failed: Items to correct noted on rear of this sheet.

SAFETY INSPECTION #2 **PASSED: 10 POINTS**

Failed: Items to correct noted on rear of this sheet.

SAFETY INSPECTION #3 **PASSED: 10 POINTS**

Failed: Reason / details are noted on rear of this sheet.

Total Safety Points:

On Site Inspection

0 or 10 points

Inspection #1: Items to address Judge: _____

Inspection #2: Items to address Judge: _____

Inspection #3: Reason Judge: _____

<http://materovcompetition.org/scoring>

SCOUT & NAVIGATOR Class Safety Inspection Protocol

2.0 Physical

All items attached to ROV are secure and will not fall off.

Examples:

loose camera

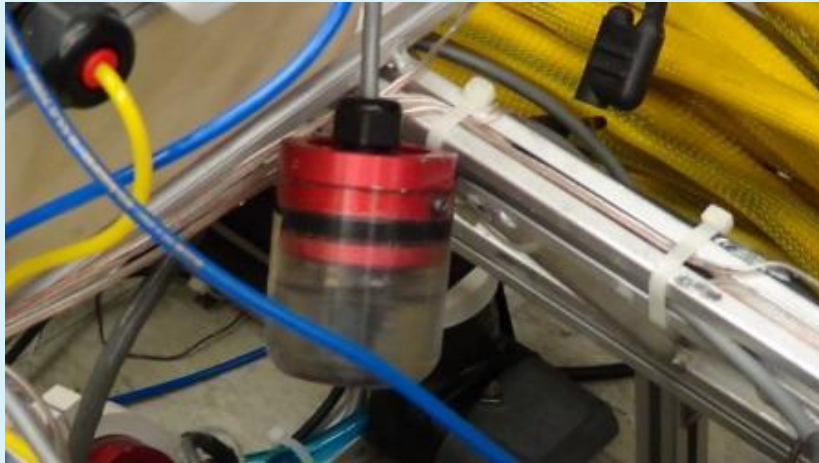

securely attached camera

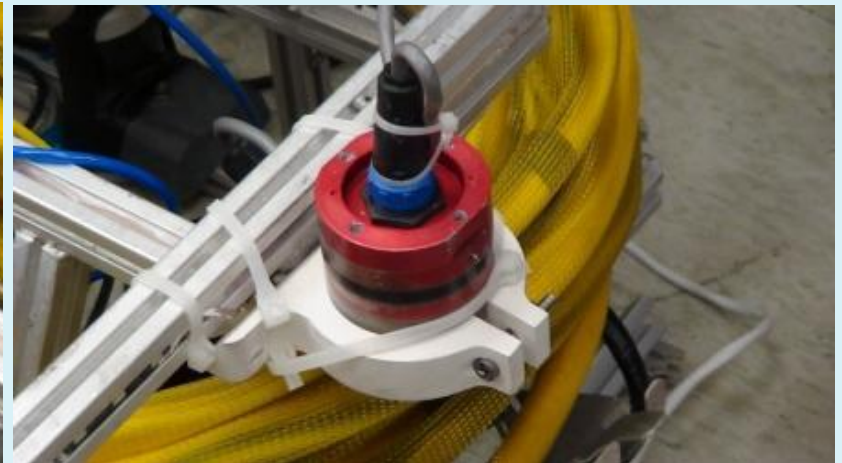

Note for NAVIGATOR class: Large monitors not secured to the control station will be considered a loose item. Any monitor / video screen should be secured to the control station or stabilized on the table.

SCOUT & NAVIGATOR Class Safety Inspection Protocol

2.0 Physical

No sharp edges or elements of ROV design that could cause injury to personnel or damage to pool surface.

Examples:

The points on the front of this ROV may look cool, but the inspector failed the company during safety inspection for putting something that could be a danger to the divers.

NOTE: Monitors with glass fronts could create sharp edges if they become broken! Monitors with glass fronts will not pass safety inspection.

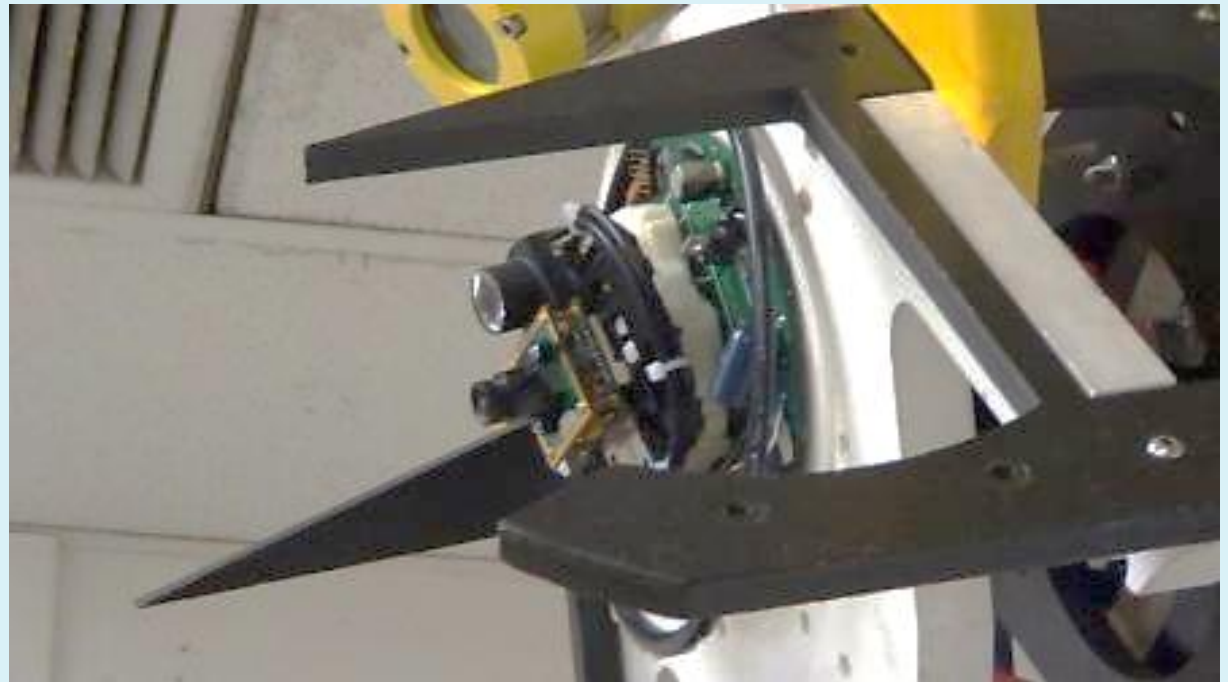

SCOUT & NAVIGATOR Class Safety Inspection Protocol

2.0 Physical

Hazardous items are identified and protection provided.

Examples:

Sharp edges on the scoop are painted red; yellow and black safety warning colors are used elsewhere. The company successfully passed their safety inspection because potentially hazardous items that are needed to complete a task are identified and protected.

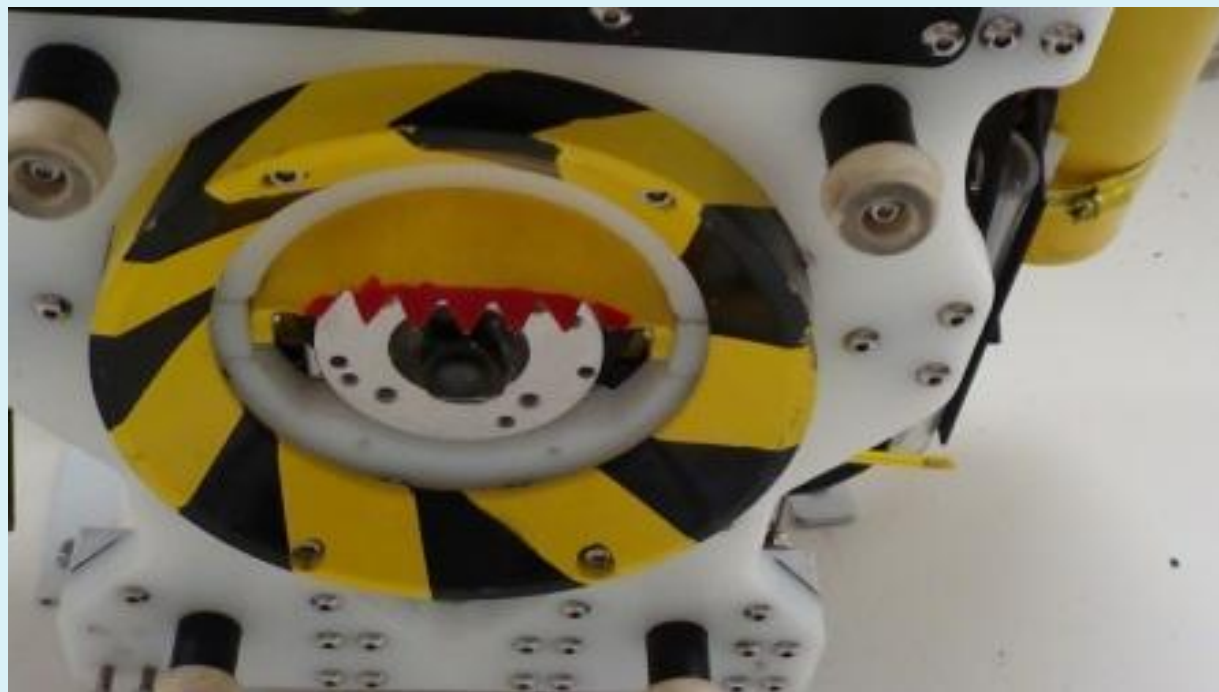

SCOUT & NAVIGATOR Class Safety Inspection Protocol

2.0 Physical

ALL Propellers must be shrouded or completely enclosed inside the frame of the ROV

If your ROV bumps up against the wall of the pool, turning propellers should not impact the side of the pool or other objects.

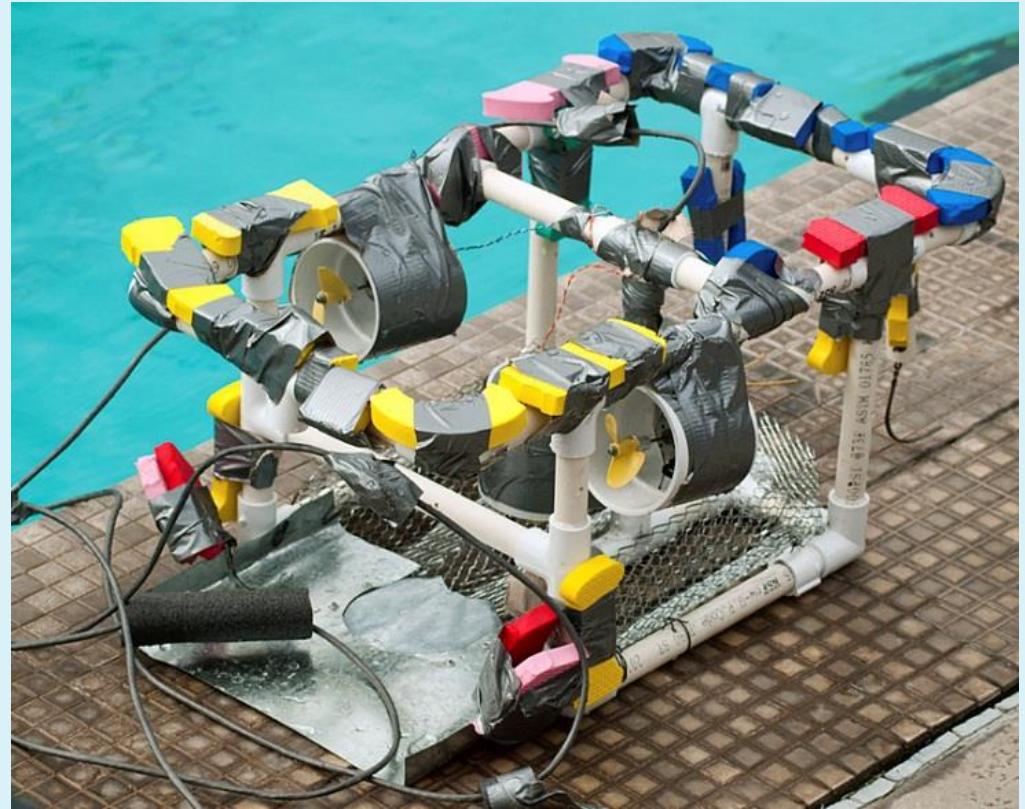

Insufficient shrouding

SCOUT & NAVIGATOR Class Safety Inspection Protocol

3.0 Electrical

Single attachment point to power source.

Anderson powerpole connectors are required to connect to the MATE power source.

A single inline fuse (not shown) must be within 30cm of attachment point (power connectors). Fuses in each line are acceptable.

NAVIGATOR and SCOUT class utilize the RED & BLACK powerpole connectors. Looking at the end of the connectors, you will see a small A on the end of each. With the tip of the A pointing up, **black** should be on the left and **red** on the right



SCOUT & NAVIGATOR Class Safety Inspection Protocol

3.0 Electrical

Problems with the Anderson powerpoles have developed when teams do NOT use the proper crimper for these connectors.

Standard Electricians Crimpers will NOT work!

The crimp must be a roll crimp not a “squish” crimp.

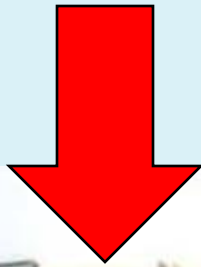

SCOUT & NAVIGATOR Class Safety Inspection Sheet Tutorial

3.0 Electrical System Interconnection Diagram (SID)

- System Interconnection Diagram (SID)** A SID is a system-level, connection diagram that includes electrical and, if applicable, fluid power wiring information. Board-level and component-level schematics should not be included; however, these may be brought to the engineering evaluation for reference purposes. The intent is to provide the competition judges with a one-line diagram showing how the various systems are interconnected without the detail of each and every wire.

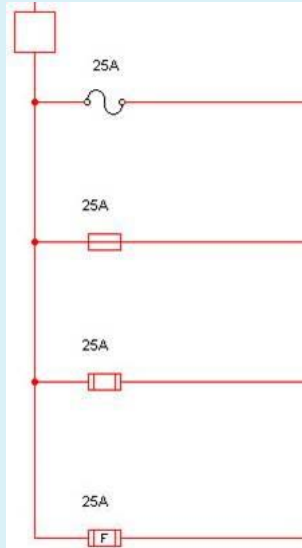

These are the only acceptable fuse symbols.
A fuse is not a box, a line with an letter S over it, or any other non-standard symbol

See the Competition Manual or the next two slides for examples of a SID. However, you must create your own SID for your vehicle. Do not directly copy the SID from a MATE resource, even if it is a proper SID for your vehicle.

Example SID 1

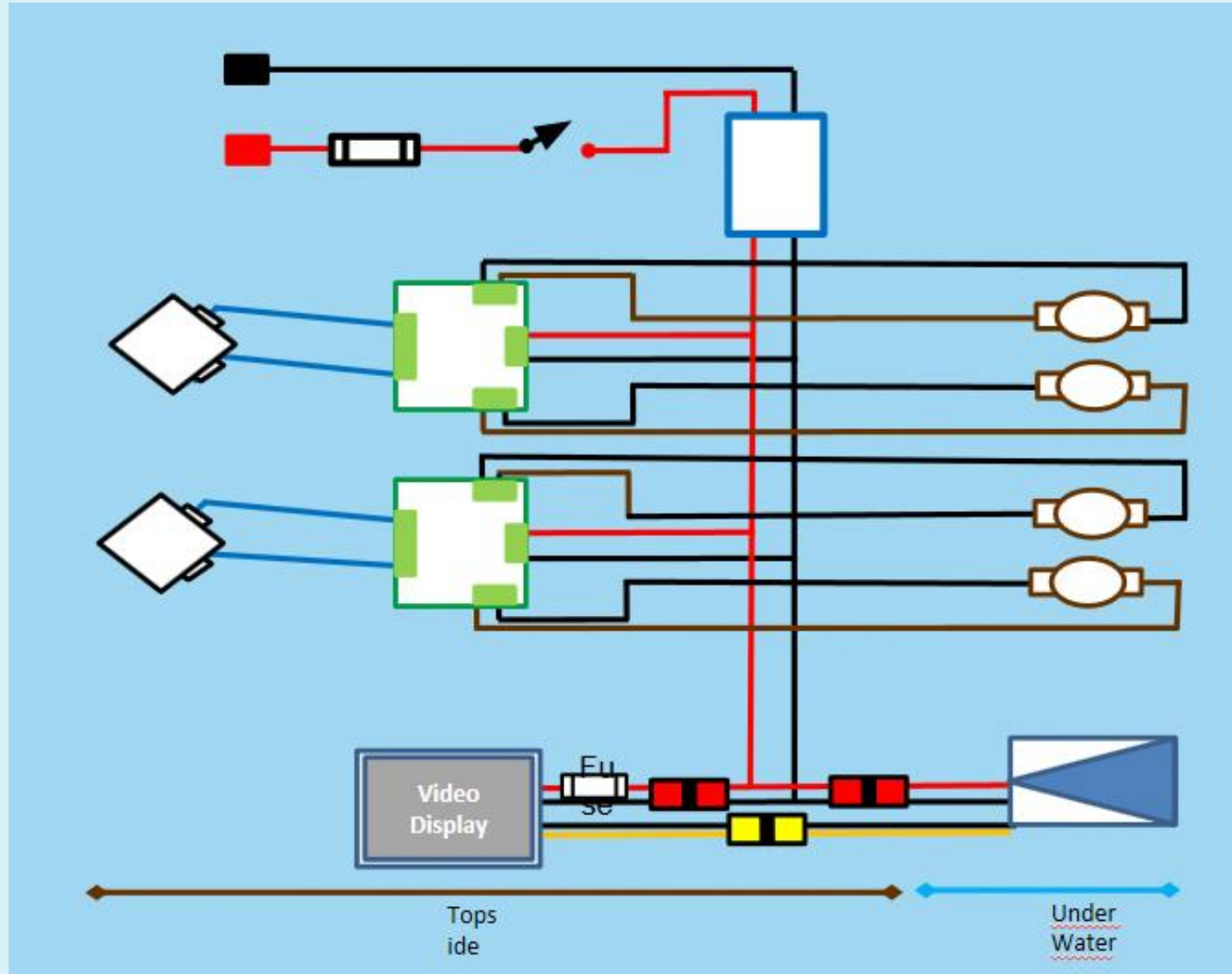

Example SID 2

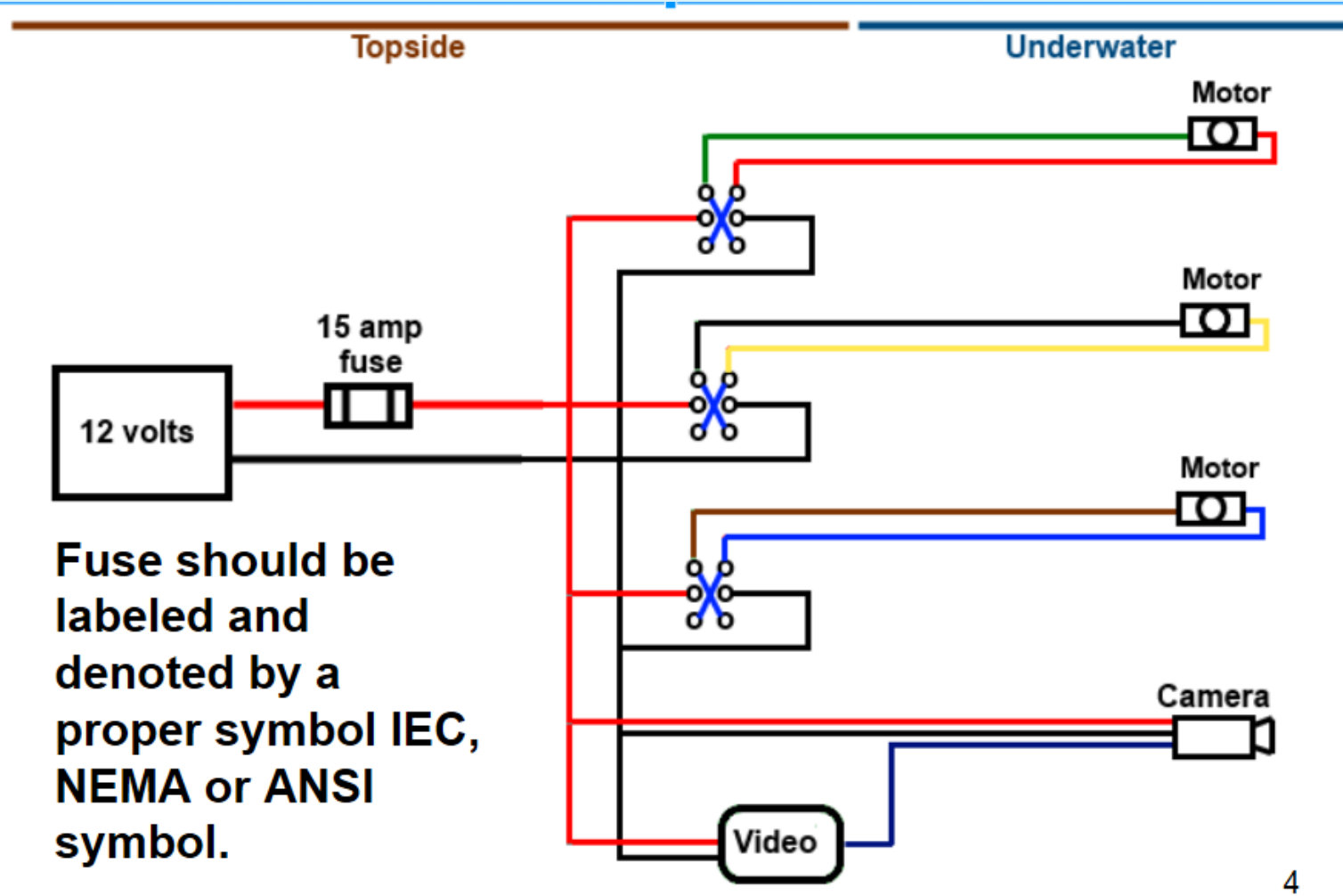

Fuse should be labeled and denoted by a proper symbol IEC, NEMA or ANSI symbol.

SCOUT & NAVIGATOR Class Safety Inspection Sheet Tutorial

3.0 Electrical

Single inline fuse within 30cm of attachment point.

Examples:

This is an example of multiple attachments ahead of the fuse that **WILL NOT PASS**. In addition, MATE no longer uses banana plugs for power attachment.

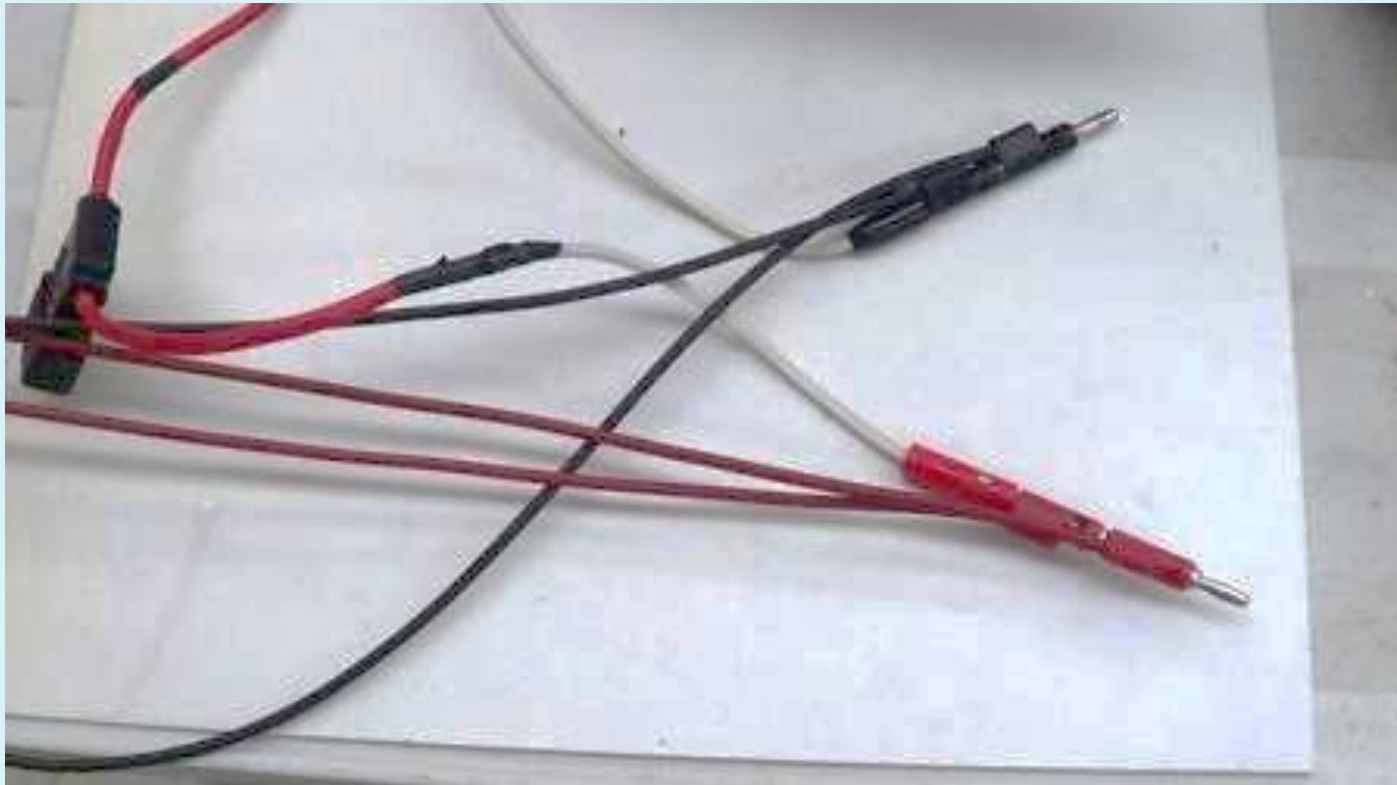

SCOUT & NAVIGATOR Class Safety Inspection Sheet Tutorial

3.0 Electrical

No exposed copper or bare wire. No exposed motors.

Examples:

These **WILL NOT** PASS. The motor on the left is both exposed and has bare wire. The motor on the right is exposed and not sealed.

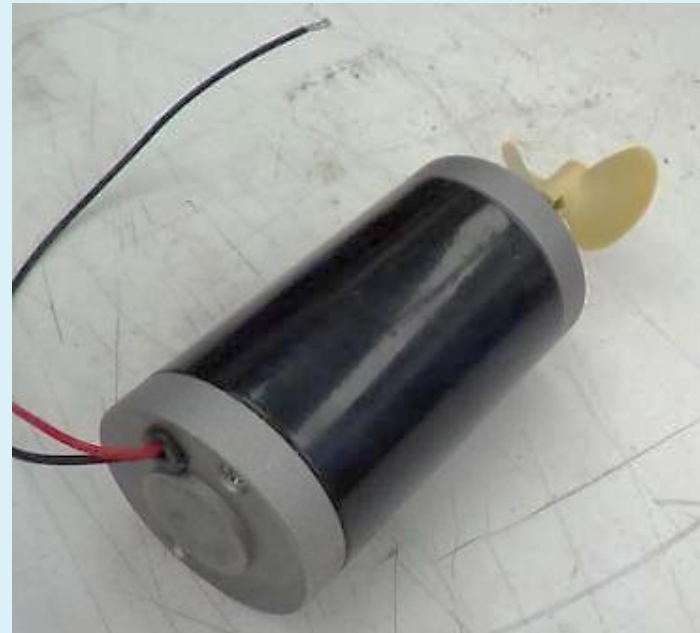

SCOUT & NAVIGATOR Class Safety Inspection Sheet Tutorial

3.0 Electrical

No exposed copper or bare wire.

Examples:

This **WILL NOT** PASS. Using banana plugs at both ends of the wire to route power from one section to another violates MATE's safety rules. It is possible for the hot end of the wire to become unplugged and create a safety hazard.



SCOUT & NAVIGATOR Class Safety Inspection Sheet Tutorial

3.0 Electrical

Tether is properly secured at surface control point and at ROV.

Example:

The wires on the ROV are loose or could get caught in a propeller when moving around the pool. Use tape, cable ties, or other methods to secure the wires away from any moving or potentially dangerous parts.



Wires entering into the control box should also be secured. If you accidentally walk the controller away from the ROV, you want any strain to be contained. You do not want to pull wires inside the control box.

SCOUT & NAVIGATOR Class Safety Inspection Sheet Tutorial

3.0 Electrical

Surface controls: All wiring and devices properly secured.

Examples:

The two pictures below are examples of loose wiring. There is no strain relief and the wires can easily pull loose from their connections. Hot melt glue and tape are not acceptable strain relief items.



SCOUT & NAVIGATOR Class Safety Inspection Sheet Tutorial

3.0 Electrical

Surface controls: All wiring and devices properly secured.

Example: both the red/black power wires and the tether wires going into the control box are properly secured by tight strain relief.



SCOUT & NAVIGATOR Class Safety Inspection Sheet Tutorial

3.0 Electrical

Surface controls: All control elements are mounted with wiring inside an enclosure.

There are multiple FAILS in the picture below!



Exposed wiring

Multiple fuses instead of single point fuse for power.

Loose wires.

Alligator clips used for connections.

No strain relief provided for wires coming from power or going to ROV.

SCOUT & NAVIGATOR Class Safety Inspection Sheet Tutorial

Fluid Power

SCOUT class or NAVIGATOR class using manual pumps only

4.0 Pneumatic / Hydraulic Checklist

- Pneumatic or hydraulic diagrams present?
- **Hand or Foot pump only?**
- Uses water or air only?
- No Pressure Accumulators?
- Any container that air is being pumped into is vented to the pool with vent holes at least $\frac{1}{4}$ " (6.35mm) in diameter?

SCOUT & NAVIGATOR Class Safety Inspection Sheet Tutorial

Fluid Power

NAVIGATOR class (only) if using pressurized fluid power.

4.0 Pneumatic / Hydraulic Checklist

- ◆ Did you PASS the pneumatics/hydraulics test?
- ◆ Do you have your pneumatic or hydraulic SID(s) present?
- ◆ Are pneumatic and/or hydraulic component specifications provided?
- ◆ Are you using pressure rated lines and fittings?
- ◆ Is your attachment to pressure source is secure?
- ◆ Is your pressure regulated to 40psi max for pneumatics and 150 psi max for hydraulics? **COMPANIES MUST PROVIDE THE REGULATOR.**
- ◆ Do your pressure vessels have a stamped pressure rating or verification by specification and do the pressure vessels have current inspection sticker?
- ◆ Are your pressure vessels secured on pool deck and not rolling around?
- ◆ If a company fabricated pressure accumulator is used, are pressure test results provided?
- ◆ Are hydraulic fluids leaking?
- ◆ Do your pneumatics utilize compressed air or inert gas?

SCOUT & NAVIGATOR Class Safety Inspection Sheet Tutorial

Fluid Power
NAVIGATOR class (only) if using pressurized fluid power.

4.0 Pneumatic / Hydraulic

Examples of Tank Certifications and Inspection Stickers

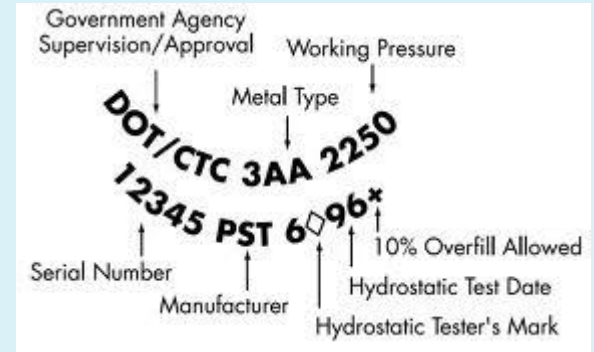
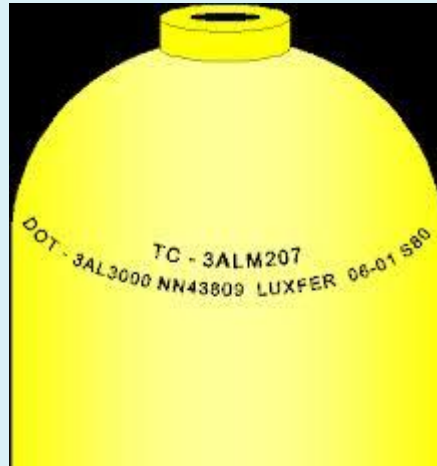

The tank must have a current visual inspection certificate (above) AND current hydrostatic test stamp (on the right).



SCOUT & NAVIGATOR Class Safety Inspection Sheet Tutorial

5.0 Laser Checklist (NAVIGATOR only)

- ◆ Did the team send the laser specs to the competition coordinator two weeks prior to the regional?
- ◆ Does your SID show the laser driver?
- ◆ Does your laser have an on/off switch on the surface controller?
- ◆ Is the laser powered through the MATE surface power supply?
- ◆ Are batteries used to power the laser? (**this is not allowed**)
- ◆ Are your lasers the proper type? Visible Laser in 630-680 nm (red) or near 532 nm (green) Class I, Class II, or Class IIIa Category; Red Laser: 5mW or less Green Laser: 1 mW or less. **Be sure and bring your laser specs to the safety inspection.**
- ◆ Is the laser voltage at or below laser rated voltage & current?
- ◆ Was a specification sheet showing laser and laser glasses sent to, **and approved by**, MATE ROV Competition officials prior to event?
- ◆ Does your ROV have a Laser shield or beam stop attachment within 30 cm of laser when out of water?
- ◆ Do the team members have laser safety glasses, regardless of the laser output power?

SCOUT & NAVIGATOR Class Safety Inspection Sheet Tutorial

SAFETY FIRST!

Our goal is not to fail teams and keep them from competing, but rather to run a fair and **SAFE** competition for all.

If you have a question or concern, You can ask your question on the MATE forum boards at: <https://forums.marinetech2.org/> or contact that MATE ROV Competition Technical Manager at mgardner@marinetech.org. In this case it is better to ask for permission, not forgiveness. Remember, it is better to be **SAFE** than sorry!