



**DIVING IN**



**2023**

**EXPLORER  
CLASS**



**BECAUSE  
TOGETHER**



**OPPORTUNITY  
RUNS DEEP!**



**COMPETITION MANUAL**

Release: December 2022

## 2023 MATE ROV COMPETITION:

### *UN DECADE OF THE OCEAN: DIVING IN TO INSPIRE SOLUTIONS BECAUSE TOGETHER OPPORTUNITY RUNS DEEP*

## EXPLORER CLASS COMPETITION MANUAL

For general competition information, including a description of the different competition classes and eligibility requirements, visit [Compete](#).

Note that this manual is intended for teams attending an in-person competition. A telepresence-specific manual will be posted at a later date.

### CONTENTS

OVERVIEW.....	2
EXPLORER CLASS DEMONSTRATION .....	4
PART 1: PRODUCT DEMONSTRATION.....	7
OVERVIEW .....	7
SCORING OVERVIEW.....	8
TIME .....	9
CONTEXT & NEED.....	10
REQUEST FOR PROPOSALS (RFP).....	10
WEIGHT RESTRICTIONS .....	18
PRODUCT DEMONSTRATION .....	19
TASK 1: Marine Renewable Energy .....	19
TASK 2: Healthy Environments from the Mountains to the Sea.....	23
TASK 3: <i>MATE Floats! 2023</i> .....	32
PRODUCT DEMONSTRATION RESOURCES .....	35
PRODUCT DEMONSTRATION RESPONSIBILITIES .....	35
PART 2: PRODUCT DEMONSTRATION PROP BUILDING INSTRUCTIONS & PHOTOS.....	35
PART 3: VEHICLE DESIGN & BUILDING SPECIFICATIONS.....	36
1.0 GENERAL.....	36
2.0 SAFETY .....	36
2.1 Job Site Safety Analysis.....	37
2.2 Safety Pre-Inspection.....	38
2.3 Onsite Safety Inspection .....	42
2.4 Safety inspection protocol .....	43
2.5 Safety Inspection Points .....	43
3.0 SPECIFICATIONS.....	43
3.1 Operational.....	43
3.2 Mechanical/Physical .....	45
3.3 Electrical .....	46

3.4 Onboard Electrical Power.....	53
3.5 Power Shutdown .....	53
3.6 Fluid Power .....	53
3.7 Control Systems .....	57
3.8 Command, Control, & Communications (C3).....	58
3.9 MATE Provided Equipment .....	59
3.10 Laser Safety Rules .....	59
PART 4: COMPETITION RULES.....	61
4.1 GENERAL.....	61
4.2 PROCEDURAL .....	62
4.3 DESIGN & SAFETY CONSIDERATIONS.....	65
PART 5: ENGINEERING & COMMUNICATION.....	66
5.1 COMPANY SPEC SHEET .....	67
5.2 TECHNICAL DOCUMENTATION .....	68
5.3 ENGINEERING PRESENTATION .....	69
5.4 MARKETING DISPLAY .....	70
5.5 CORPORATE RESPONSIBILITY .....	72
TIPS FOR EFFECTIVE WRITTEN AND ORAL COMMUNICATION.....	73
PART 6: SUBMISSION GUIDELINES AND KEY DEADLINES.....	74
6.1 Documentation .....	74
6.2 KEY DEADLINES .....	77



This work is licensed under a [Creative Commons Attribution-NonCommercial-NoDerivatives 4.0 International License](https://creativecommons.org/licenses/by-nc-nd/4.0/). Under this license you may download this document. Please give credit to MATE II. You may not use these materials for commercial purposes without written permission from MATE II. Please click on the Creative Commons link above for license details.

[www.materovcompetition.org](http://www.materovcompetition.org)  
[www.mateii.org](http://www.mateii.org)

Edits are highlighted in yellow.

January 13, 2023. Pg. 30 – 31. The pipe of the heavy container was increased from 3-inch pipe to 4-inch pipe.

## OVERVIEW

### From Technical to Teamwork, Problem-Solving, Creativity, and Critical Thinking: MATE Develops Skills for Success in the Workforce

As you prepare to harness the energy of offshore wind and solar, ensure healthy ecosystems from the mountains to the sea, and deploy technologies to monitor ocean conditions, make sure to find a

moment to reflect on the skills that you are developing to allow you to tackle these tasks. These are the skills that you will take with you along your educational journey and pathway into the workplace.

They also happen to be the skills that are in high demand by employers around the globe. Machine learning, data analytics, AI, video marketing, critical thinking, creativity, collaboration, time management, and leadership – articles published by [LinkedIn](#) and [Forbes Magazine](#) highlight these technical and employability (aka “soft”) skills as the most “in-demand for the next 10 years” and, likely, beyond.

A number of these skills could be described as “entrepreneurial,” part of a skill set that also includes the ability to understand the breadth of business operations (from using data analytics to make informed financial decisions to researching and critiquing potential design solutions and producing content for media outreach); acknowledge your strengths (and weaknesses!); work as an integral part of a team; and apply technical knowledge and skills in new and creative ways. By developing a business acumen, a mindset for innovation and collaboration, and an understanding of how to take environmental, social, and governance (ESG) factors into consideration when making business decisions, you will be well prepared for the global workplace and ready to tackle today’s (and tomorrow’s!) challenges.

As you read through this manual you will see the following icons:\*



These icons correspond to the employability (orange) and ROV-specific (green) knowledge and skills that you gain as you build your ROV and prepare for the competition and which of the various competition requirements – from the Product Demonstration to Engineering and Communication – help to develop each of these skills.

*\* These icons are from [Evaluate-Compete](#), which is designed to help give you a competitive edge in preparing for the competition and the workforce! High school and college teams are invited to participate in the project's pilot testing phase. Visit [Evaluate-Compete](#) for more information."*

## THINK OF YOURSELVES AS ENTREPRENEURS

In this way, the MATE ROV Competition not only encourages you to reflect on the skills that you develop, but, for more than a decade, has also challenged you to think of yourself as an entrepreneur, embrace the skills that being one requires, and transform and organize your team into a start-up company. Use the following questions as a guide to assist you with this process:

- What is your company name?
- Who are its leaders, including the:
  - CEO (chief executive officer – the leader)
  - CFO (chief financial officer who oversees the budget and spending)
- Who manages Government and Regulatory Affairs (i.e. who’s in charge of reviewing the competition rules and making sure that they are understood and followed by everyone)?
- Who is responsible for research and development (aka R&D)?
- Who is responsible for system(s) engineering? Design integration? Testing? Operations?
- Who is responsible for fund-raising, marketing, and media outreach?
- Who is the company’s ESG research and engagement analyst?
- What other positions might you need? (Depending on your personnel resources, more than one person may fill more than one role.)
- What products and services do you provide?
- Beyond MATE, who are your potential clients?

**“DELIVER, TOGETHER, THE OCEAN WE NEED FOR THE FUTURE WE WANT!”**

In short, the [MATE ROV Competition’s philosophy](#) is about student learning. It is about the knowledge and skills gained through participating in the competition and how that knowledge and those skills prepare you for your future career in the ocean STEM workforce – and [beyond](#).

As you contemplate your future education and career plans, the challenge presented to you today is how to apply your knowledge and skills to addressing the competition mission tasks so that we can “deliver, together, the ocean we need for the future we want!”

Again this year the MATE ROV Competition is highlighting the [United Nations Decade of Ocean Science for Sustainable Development](#) and aligning its mission tasks with one or more of the [17 UN Sustainable Development Goals](#). This 2023 MATE ROV Competition also continues to inspire ESG principles in order to do “good for good” for our ocean planet and global community. These “clients” once again present you with request for proposals (RFP), the specifics of which are included below.

**EXPLORER CLASS DEMONSTRATION**

**All EXPLORER class companies are required to submit a video that:**

- Demonstrates the ability of their vehicle to perform specific tasks;
- Shows compliance with MATE’s design, build, and safety specifications.

**Video specifications:**

Video specifications: The video MUST show the following ROV features for the specified amount of time. Companies can choose to narrate the video to help explain how their vehicle meets these required specifications. Alternatively, a MATE official may schedule a Zoom, Skype, Google Hangout, GoToMeeting, Webex or other type of video conferencing session with the company. During the session, companies must visually show, and answer questions about, the following ROV features.

The video MUST show in this order:

1. 15 seconds (or more) of the 48-volt power supply **(ELEC-002E)**.
2. 15 seconds (or more) showing a properly sized Littelfuse. The company MUST use a ruler to show that this fuse is within 30 cm of Anderson Powerpole connectors. **(ELEC-008E, ELEC-010E)**.
3. 30 seconds (or more) of the inside of the control box showing the wiring and components. If the company uses a control box, 30 seconds showing the inside of the control box including the wiring and components. MATE will be looking for:
  - No exposed wiring **(ELEC-017E)**.
  - That the control box is neatly laid out with attention to workmanship. **(ELEC-022E)**.
  - Separation and identification of 120VAC wiring from DC and control voltages. **(ELEC-023E)**. If 120VAC is not used in the control box, you should video a slide stating that AC power is not used in the control box.If the company does not use a control box, 15 seconds (or more) showing the entire control system (controller, laptop/computer, etc.).
4. 15 seconds (or more) in the control system showing that there is no conversion of the 48V until it reaches the ROV. Power supplies, ESCs, H-Bridges or other voltage conversion devices are not allowed on the surface. **(ELEC-003E & ELEC 004E)**.
5. 30 seconds (or more) showing any hydraulic / pneumatic systems including a pressure release valve and regulator in the system **(FLUID-007, FLUID-011)**, and that any pressurized cylinder, pressure storage device meets the MATE specifications of **(FLUID-012, FLUID-013)**. **New in 2023**, 15 seconds (or more) showing the specifications for pneumatic components, including the pressure rating of any tubing used. In addition, the type of fluid should be clearly stated in the video **(FLUID-002, FLUID-003, FLUID-004)** If the vehicle does not use fluid power, **you should video a slide stating that Fluid Power is not used on this ROV for 10 seconds.**
6. 15 seconds (or more) showing the top-side strain relief. The video must show the tether and wires, with strain relief, entering the control station or topside controller **(ELEC-024E)**.
7. 15 seconds (or more) showing the bottom-side strain relief. The video must show the tether entering the ROV and strain relief for the tether **(ELEC-024E)**.
8. 60 seconds (or more) total, 10 seconds (or more) per side of the ROV (4 sides plus top and bottom) showing that all motors are waterproofed, and propellers are shrouded and protected with guards. There are no sharp edges or elements of the ROV that could cause damage **(MECH-006, ELEC-017E)**.

Video demonstrating specific tasks: Following those requirements, the video must demonstrate that the ROV can complete the following product demonstration tasks. The ROV must complete all the tasks within 15 minutes.

The UNCUT video must show the vehicle:

1. Launching safely from the side of the pool and maneuvering to tasks.

- a. See specifications **(MECH-004 & MECH-005)**.
- 2. Completing the required tasks. This includes:
  - a. **Task 1:** Marine Renewable Energy
    - i. Install a floating solar panel array
      - 1. Tow the solar panel array from the side of the pool to a point at least 1.5 meters away from the side of the pool.
      - 2. Moor the panel array to ONE anchor point

NOTE: Companies do not need to simulate the three floating wind turbines; they only need to tow the floating solar panel array 1.5 meters away from the side of the pool and moor the panel array to one (not three) anchor point.

- b. **Task 2:** Healthy Environments from the Mountains to the Sea
  - #2A: Coral Reefs and Blue Carbon
    - i. Administer Rx to diseased corals – Probiotics
      - 1. Place a tent over the diseased area of coral
      - 2. Insert a syringe into the port

NOTE: After inserting a syringe the port, companies do not need to inject fluid into the tent.

- #2B: Inland Lakes and Waterways
  - ii. Reintroduce endangered native Northern Redbelly Dace
    - 1. Transport the fry to a safe release area
    - 2. Allow the fry to acclimate to local conditions
    - 3. Release the fry

NOTE: The safe area can be simulated by a square up to 50 cm x 50 cm in length. Companies do not need to construct the potential sites as described in the Prop Building document, nor do they need to simulate invasive predatory fish.

The camera angle must demonstrate that the ROV is under its own power and not assisted by humans when in the water. The MATE ROV Competition requires that the camera show the complete ROV in the field of view at all times. A video that cuts between camera angles will not pass the demonstration requirement of “uncut” footage. The video is permitted to show a split screen or may incorporate a separate window showing the ROV camera or other footage. However, the video **MUST** show an uncut view of the vehicle from launch to completion of the tasks. The tasks must be completed within 15 minutes.

Companies may complete the tasks in any order they wish.

\* Companies that advance from an EXPLORER class regional with 5 teams or more are not required to submit qualification videos.

See [Documentation Submissions Guidelines](#) for submission information. Additional submission information can be found in **PART 6: SUBMISSION GUIDELINES AND KEY DEADLINES**.

Companies are allowed to make minor changes to their ROV after their video demonstration, but the overall systems must be the same. Minor changes include adding/removing buoyancy, adding tools/sensors that were not used for the demonstration, etc. The frame, motor configuration, and the control system must be the same for the video demonstration and the World Championship competition. Safety inspectors will refer to images of the ROV and control system taken from the demonstration video. Vehicles with different systems will not pass the safety inspection.

### **NOTE for 2023!!!**

Due to the continued impact of the pandemic, EXPLORER class teams may or may NOT be encouraged to attend RANGER/NAVIGATOR/SCOUT regional events this competition season to showcase their vehicle. [Contact your regional coordinator](#) to determine whether or not you will be encouraged to attend the regional event.

Regional competitions benefit from the participation of EXPLORER class companies by:

- Showcasing EXPLORER ROVs to RANGER, NAVIGATOR and SCOUT class companies to help them to learn about advanced systems and get ideas for “next year”
- Inspiring RANGER, NAVIGATOR, and SCOUT students to see what’s possible if they continue to progress through the competition classes
- Providing examples of educational pathways and potential post-secondary institutions and programs to continue to pursue STEM learning
- Having access to additional volunteers and judges

Companies benefit from attending the regional by:

- Having access to the product demonstration props and the opportunity to conduct a “wet” run
- Receiving feedback from safety inspectors, including identification of potential safety violations and what can be done to enhance their vehicle from a safety standpoint
- Receiving technical help from engineers and technicians as well as from other companies
- Gaining insight and sharing ideas with other companies
- Earning points for the corporate responsibility portion of the competition

## **PART 1: PRODUCT DEMONSTRATION**



### **OVERVIEW**

**EXPLORER** class companies will take part in ONE product demonstration that consists of three distinct tasks:



**TASK #1: Marine Renewable Energies**

**TASK #2: Healthy Environments from the Mountains to the Sea**

**TASK #3: MATE Floats!**

**NOTE:** For EXPLORER class companies participating in regionals, your regional competitions may not include all 3 tasks of the product demonstration; regional competitions may also give companies more than one attempt at the product demonstration. Contact [your regional coordinator or visit your regional contest's website](#) to determine what will take place at your regional competition. Regardless, the product demonstration score will be added to your [ENGINEERING & COMMUNICATION](#) and [SAFETY](#) scores to determine your total, overall score for the competition.

## **SCORING OVERVIEW**

The competition consists of product demonstrations, engineering and communication, and safety with the following scoring breakdown:

- **Product demonstrations**
  - 300 points (max), plus a time bonus
  - Weight restrictions
    - 10 points (max)
  - Product demonstration organizational effectiveness
    - 10 points (max)
- **Engineering & Communication**
  - Technical documentation
    - 100 points (max)
  - Engineering presentations
    - 100 points (max)
  - Marketing displays
    - 50 points (max)
  - Company Spec Sheet
    - 20 points (max)
  - Corporate Responsibility
    - 20 points (max)
- **Safety**
  - Initial Safety and Documentation Review
    - 20 points (max)
  - Safety Inspection
    - 30 points (max)
  - Job Safety Analysis (JSAs)
    - 10 points (max)

**TOTAL POINTS = 670**

**NOTE: For EXPLORER class companies attending regional competitions, your regional may not require all of the Engineering & Communications components or offer the opportunity to earn points for Corporate Responsibility. Contact [your regional coordinator or visit your regional contest's website](#) for more information.**

## **TIME**

Each product demonstration includes:

- 5 minutes to set up at the product demonstration station
- 15 minutes to attempt the tasks
- 5 minutes to break down and exit the product demonstration station

Your company will have 5 minutes to set up your system, 15 minutes to complete the tasks, and 5 minutes to demobilize your equipment and exit the product demonstration station. During the 5-minute set-up, you may reassemble your vehicle after the weigh-in and place it in the water for testing and/or trimming purposes. The 15-minute demonstration period will begin after the full 5 minutes of set up time expires, regardless of whether the company is ready to start the product demonstration. It may begin sooner if your CEO notifies the product demonstration station judges that your company is ready to begin.

At any time during the demonstration, you may pilot your ROV to the surface and remove the vehicle from the water for such things as buoyancy adjustments, payload changes, and troubleshooting, but the 15-minute product demonstration clock will only stop if a judge determines it is necessary for reasons beyond your control. Otherwise, the clock will only stop after all of the tasks are successfully completed, the ROV has been piloted into the “resident ROV” docking station under its own power. Your ROV is not required to return to the surface between tasks.

Your 5-minute demobilization will begin as soon as the 15-minute demonstration time ends, regardless of where your ROV is located (i.e., still at depth, in the docking station, on the surface, etc.).

Regional competitions may alter the set-up, product demonstration time, or demobilization time. Contact [your regional coordinator or visit your regional contest's website](#) to verify the timing of your product demonstrations.

## **TIME BONUS**

Companies will receive a time bonus for each product demonstration if you:

- 1) successfully complete all the tasks,
- 2) successfully pilot your ROV into the “resident ROV” docking station

Companies will receive 1 point for every minute and 0.01 point for every second under 15 minutes remaining.

## CONTEXT & NEED

This competition season the MATE ROV Competition is celebrating! MATE Inspiration for Innovation and the Marine Technology Society are joining forces to expand our reach, leverage our collective partnerships and resources, and grow our missions. For MATE, it's a homecoming; the competition was created in 2001 in partnership with the MTS ROV Committee as a workforce development platform for the offshore maritime industry. We have evolved and expanded over the years, but the mission to inspire and develop the next generation of ocean professionals remains at our core.

In addition to the celebration, join us as we continue to highlight the [United Nations Decade of Ocean Science for Sustainable Development](#), embrace and inspire ESG, and challenge our global community of learners to come together to imagine, innovate, and create solutions to the problems that impact us all.

As we shared last year, the United Nations proclaimed a *Decade of Ocean Science for Sustainable Development* (2021-2030) to support efforts to reverse the cycle of decline in ocean health and to gather the global community behind a common goal: creating improved conditions for sustainable use and development of our world ocean.

Like last year, the three 2023 competition mission tasks focus on SOLUTIONS – from marine renewable energies to Blue Carbon, “prescriptions” for diseased coral, conservation programs for endangered species, and GO-BGC floats to monitor ocean health. We embark on this season with optimism that together we can inspire, innovate, and create technology solutions to mitigate the impacts of climate change and pave the way to a sustainable future. And with the ocean observations and scientific research to support us, we are also optimistic that we can influence mindsets and guide communities to embrace and adapt practices for the good of us all.

And again this MATE ROV Competition season the “client” is us – our global community – and each task area included within the request for proposals (RFP) aligns with one or more the [17 UN Sustainable Development Goals](#). While not specific to the Decade of the Ocean, these goals offer a blueprint to achieve a better and more sustainable future for all. And like last year, each task also embraces [ESG](#) – the environmental, social, and governance factors that more and more companies and organizations are taking into consideration when making business and management decisions.

The MATE ROV Competition is challenging its community to design and build a remotely operated vehicle and the necessary sensors, tooling, and complementary technologies to combat climate change, provide clean energy, monitor ocean health, and heal and protect our aquatic habitats from the mountains to the sea so that we can “[deliver, together, the ocean we need for the future we want!](#)”

## REQUEST FOR PROPOSALS (RFP)

### 1. General

#### a. *Marine Renewable Energy*

*UN Sustainable Development Goals:*

*#7 Affordable and Clean Energy*

*#12 Responsible Consumption and Production*

This appeared in last year’s competition manual and it’s worth repeating – marine renewable energies (MREs), such as offshore wind farms, tidal turbines, wave energy converters, and floating solar panels, play a key role in mitigating the effects of climate change and paving the pathway to a sustainable future. MREs provide a significant contribution to the production of low-carbon renewable energy around the world and are an important ally in the fight against climate change.

Innovative minds employed at organizations that embrace ESG are exploring the idea of installing floating solar “parks” amongst existing offshore wind farms. This would allow the solar arrays to leverage the existing infrastructure (including resident ROVs for cleaning and maintenance), tie into the grid transporting power to shore, and minimize the increase to the overall footprint of the combined assets. The last feature in that list will be particularly advantageous for overall management and safety, especially when it comes to ocean-going vessels and charismatic megafauna traversing the area.

That said, the offshore wind farm serviced in last year’s mission challenge is preparing to welcome a new “crop” – floating solar arrays. Installing these amongst established floating turbines has never been done before and certainly presents a variety of challenges, but that will not prevent us from tasking MATE competitors to – borrowing a line from long-time partner [Oceaneering International](#) – “solve the unsolvable” advance solutions that help to reduce CO2 emissions.



*SolarDuck floating panel solar arrays ([SolarDuck and Partners to Build and Test Offshore Floating Solar Platform ‘Merganser’ | Energy | News \(oceannews.com\)](#))*

- b. Healthy Environments from the Mountains to the Sea*
- Coral Reefs and Blue Carbon*
- Inland Lakes and Waterways*
- UN Sustainable Development Goals:*
  - #13 Climate Action*
  - #14 Life Below Water*

A drop of water that begins its journey in an inland pond high in the Rocky Mountains – or even higher up in Lake Titicaca in the Peruvian Andes – will eventually make its way to the sea, where it could end up flowing over a coral reef and becoming a genetic “fingerprint” of the organisms that make their home there. Or where it once flowed through the gills of Redbelly Dace hiding in grasses of an emergent wetland, it could now flow over the gills of seahorses anchoring themselves on blades of seagrasses or the chain links of an [Eco-Mooring System](#).

Students at the [St. Vrain Valley Innovation Center](#) in Longmont, CO appreciate this first-hand. Partnering with [Boulder County Parks and Open Space](#), [Colorado Parks and Wildlife](#), and the [Ocean First Institute](#), among other state and regional organizations, students played a significant role in a real-world conservation project to reintroduce a native fish species, the Northern Redbelly Dace. After rearing dace fry in laboratory aquaria, students monitored water quality both in-house and in the field and released the fry in a restored wetland habitat in an area safe from predators.

Innovation Center students have also helped to ensure the integrity and safety of another habitat – the Dillon Reservoir Recreation Area. Starting with an OpenROV, students have inspected ropes that hold the buoys that mark the dam water intakes – and may one day use a [BlueROV2](#) to help to uncover a mystery. In the late 1950s, the Denver Water Board voted to build a dam to secure water for the Front Range; the Old Town of Dillon was flooded. More than 70 years later it sits as a western “ghost town” at the bottom of the lake, with many buildings and homes – and their contents – still intact.

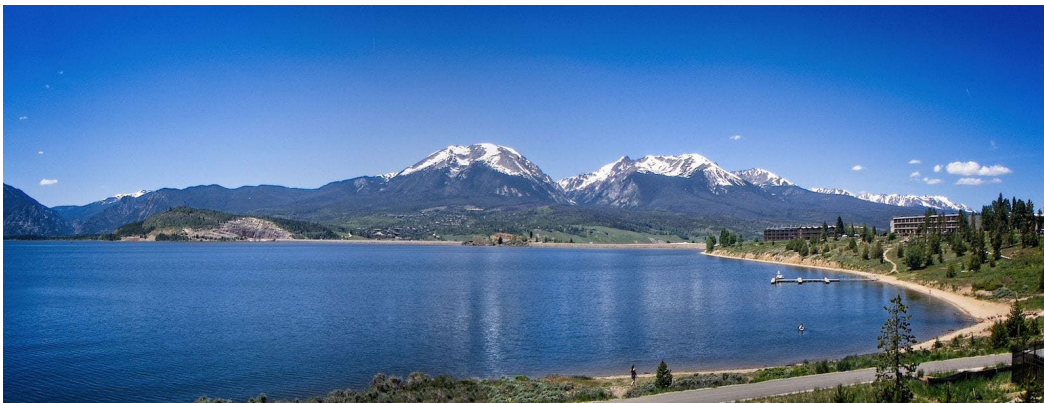

*Dillon Reservoir Recreation Area*

*([Dillon Reservoir Recreation Area – Dillon and Frisco, CO | Biking, Boating, Camping, Fishing, Hiking on Lake Dillon in Summit County \(uncovercolorado.com\)](#))*

Another project that Innovation Center partners have been involved with takes place more than 7,200 kilometers away from Dillon Reservoir and the restored habitat of the Redbelly Dace. Lake Titicaca is home to [the world’s largest entirely aquatic frog](#); its classification as endangered by international conservation authorities means that not just the frogs, but also the lake is under significant threat. The Denver Zoo is working to understand and mitigate these threats through research, conservation breeding, community engagement, capacity building, and more. Like the Northern Redbelly Dace, the conservation of the Lake Titicaca giant frog is critical for both the species and the environments that

they support.



*The Lake Titicaca giant frog ([Peru – Denver Zoo](#))*

Not quite so far away from the Rockies, scientists at the [Smithsonian Marine Station](#) in Fort Pierce, FL, are evaluating various treatments to heal diseased areas of coral reefs. While still unclear if the culprits are bacterial, viral, or fungal, the detrimental effect they have is exacerbated by the warming waters of climate change. The “prescriptions” these researchers are studying include probiotics to enable the corals to heal themselves and UV light to irradiate and kill diseased coral tissue. Unlike antibiotics that do not provide lasting protection and may encourage the selection of antibiotic resistant pathogens, probiotics could colonize a host and provide lasting protection to diseased corals. And while UV irradiation may also damage healthy coral tissue, their studies have shown that healthy coral tissue can more readily heal.

Smithsonian Institution scientists are also using [environmental DNA](#) (aka “eDNA”) as genetic fingerprints to determine the species that inhabit these reefs. This information allows them to better understand the diversity of species (without having to capture them) and make better informed decisions about their management and conservation.



*A plastic bag with weighted line along the bottom is used to “tent” an area of diseased coral that will soon receive a dose of probiotic treatment.  
(Hunter Noren, Nova Southeastern University)*

Photogrammetry is another “tool” that scientists are using to study and “fingerprint” coral reefs. [Photogrammetry](#) is a method of approximating a 3D structure using two dimensional images where photographs are stitched together using photogrammetry software to make the 3D model. The Smithsonian Institution has used photogrammetry to create a beautiful collection of corals from their archives.



[Corals | 3D Digitization \(si.edu\)](#)

Like coral reefs, seagrass meadows are also important habitat for a variety of species – from seahorses to sea turtles. And as was shared last year, seagrasses are extremely effective at absorbing and storing CO<sub>2</sub>, which makes them key allies in combating climate change and important environments to protect and conserve.

The water cycle is a process that most of us memorized to pass our middle school grade science test. However, if we allow it, it can also serve as a reminder of the interconnectivity of our Blue Planet and how changes thousands of miles away from a coastline, or thousands of miles away from the open seas, can impact each other in either positive or negative ways. The UN Decade of the Ocean, as well as the location of the 2023 World Championship, provides the opportunity to challenge competitors around the globe to recognize that climate change isn’t limited to oceans and coastal communities; it impacts inland lakes and remote mountain villages.

*c. MATE Floats!*  
*UN Sustainable Development Goal:*  
*#13 Climate Action*

The goal of the [National Science Foundation \(NSF\)-funded GO-BGC Project](#) is to build a global network of chemical and biological sensors that will monitor ocean health. Scientists, engineers, and technicians from multiple organizations are using NSF grant funds to build and deploy 500 robotic ocean-monitoring floats around the globe. The temperature, depth, and bio-geochemical information that these floats

collect will add significantly to the repository of data needed to better understand ocean processes and predict the consequences of climate change.

The primary focus of the competition is, obviously, on engineering ROVs. However, the opportunity to present competitors with the challenge of designing and building another type of underwater technology, one that contributes to observations and research critical to understanding the impact of climate change, could not be missed.

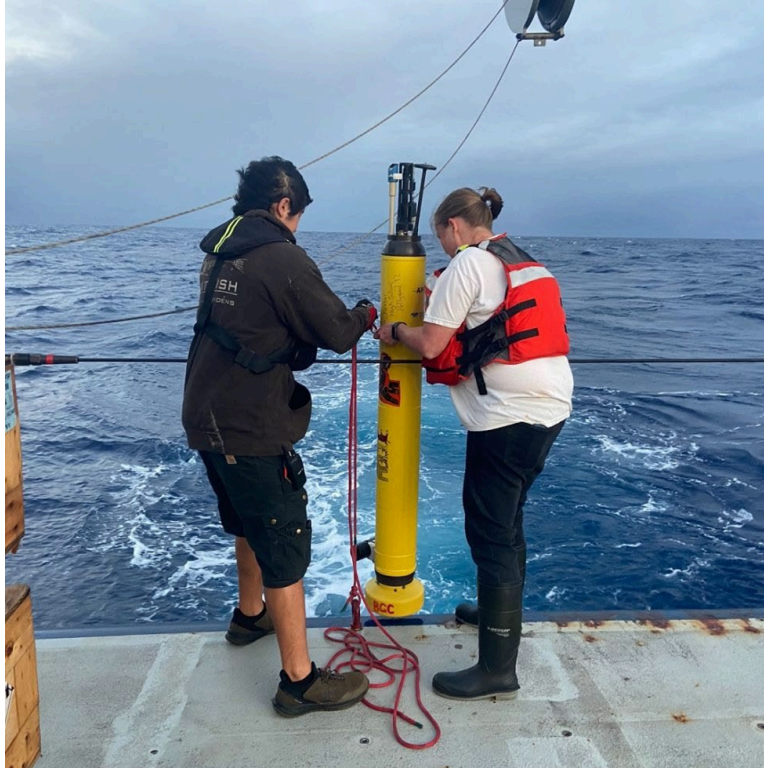

*Deploying a GO-BGC float in the middle of the Pacific Ocean ([\(20+\) Global Ocean Biogeochemistry Array / Facebook](#))*

## **THIS IS WHERE YOUR MISSION BEGINS.**

### ***a. Mission Scope and Purpose***

This and the following sections contain the technical specifications and requirements for ROV services needed to support the *UN DECADE OF THE OCEAN: DIVING IN TO INSPIRE SOLUTIONS BECAUSE TOGETHER OPPORTUNITY RUNS DEEP*. In 2023, ROV services include:

#### **1) TASK 1: Marine Renewable Energy**

##### **UN Sustainable Development Goals:**

##### **#7 Affordable and Clean Energy**

##### **#12 Responsible Consumption and Production**

- Position a solar panel array amongst floating wind turbines
- Moor the panel array to three anchor points



- Connect the floating solar panel array to grid
- Remove biofouling from the floating wind turbines
- Pilot into a “resident ROV” docking station

## 2) **TASK 2: Healing Corals and Preserving Blue Carbon**

### **UN Sustainable Development Goals:**

#### **#13 Climate Action**

#### **#14 Life Below Water**

#### **Coral Reefs and Blue Carbon**

- Measure the dimensions of the diseased coral head and create a 3D model of the coral head labeled with the proper dimensions
- Collect a water sample from above the coral head
- Use the eDNA data to identify coral reef species
- Position a simulated UV light source over the diseased area of coral
- Irradiate the diseased area of coral
- Place a tent over diseased coral and inject a “probiotic” fluid into the tent
- Compare photos to determine the recovery of seagrass from an anchor scar
- Install an Eco-Mooring to protect seagrass and seahorse habitat

#### **Inland Lakes and Waterways**

- Search two potential sites for invasive predatory fish species to determine which one is safe for release
- Transport the fry to safe release area
- Allow the fry to acclimate to local conditions
- Release the fry
- Inspect buoy ropes for damage
- Determine the lift capability of your ROV
- Lift the container and return it to the surface, side of the pool
- Fly a transect and count the number of frogs in the transect
- Install a long-term camera into the designated area on the bottom of the lake

## 3) **TASK 3: *MATE Floats!***

### **UN Sustainable Development Goal:**

#### **#13 Climate Action**

- Prior to the competition, design and construct an operational vertical profiling float
- Float communicates with the mission station prior to descending
- Float completes two vertical profiles communicating the time to the mission station after each profile

## 2. **Specifications**

See the specific tasks described below as well as the [VEHICLE DESIGN & BUILDING SPECIFICATIONS](#) and [PART 4: COMPETITION RULES](#) sections.

### 3. Maintenance and Technical Support

The company shall warrant the ROV and associated systems and equipment for at least the duration of the product demonstrations. Repair or replacement shall be at the company's expense, including the cost of shipping the ROV to and from the competition facility.

During regional events, the company shall provide at least one day of technical support to resolve hardware, software, and operational issues. They shall provide at least three days of the same for the World Championship event.

### 4. Shipping and Storage

Refer to [Shipping Information](#) for specifics on shipping to the MATE World Championship site.

Delivery of the ROV and associated systems and equipment shall be no later than the date of the geographically closest regional contest or by the first day of the MATE World Championship (June 22, 2023).

### 5. Evaluation Criteria

- a. Technical documentation
- b. Engineering presentation
- c. Marketing display
- d. Company spec sheet
- e. Product demonstration
- f. Safety

### 6. References

#### a. GENERAL

- [United Nations Decade of Ocean Science for Sustainable Development](#)
- [17 UN Sustainable Development Goals](#)
- [A Hotter Future Is Certain, Climate Panel Warns. But How Hot Is Up to Us](#)
- [ESG \(environmental, social and governance\)](#)
- [Ocean energy: An important ally in the fight against climate change](#)
- [Marine Renewable Energy](#)
- [The Blue Carbon Initiative](#)

#### b. TASK 1: Marine Renewable Energy

- [The Technology of Offshore Wind Power and the Morro Bay Wind Farm](#)
- [RWE and SolarDuck to Explore and Develop Offshore Floating Solar Parks Globally](#)
- [Floating Solar Anchoring and Mooring](#)
- [SolarDuck – Offshore Solar Energy](#)

c. **TASK 2: Healthy Environments from the Mountains to the Sea**

- [Photogrammetry Unlocks the Potential of Deep Sea Corals](#)
- [Scientific breakthrough could save Florida's threatened coral reefs](#)
- [Underwater 3D Imaging Helps Seafood Producers Better Understand the Seabed](#)
- [Environmental DNA \(eDNA\) | Center for Ocean Solutions](#)
- [Stony coral tissue loss disease \(SCTLD\)](#)
- [New Mapping Tools Helping to Protect Seagrass](#)
- [Studland Bay 'eco-moorings' set up to protect seahorses](#)
- [Northern redbelly dace recovery](#)
- [Northern Redbelly Dace release video](#)
- [Summit County Water Rescue Team deploys new, state-of-the-art underwater drone to help with rescues](#)
- [Peru - Denver Zoo](#)
- [Lake Titicaca giant frog: Scientists join forces to save species](#)

d. **TASK 3: MATE Floats!**

- [GO-BGC | Global Ocean Biogeochemistry Array](#)
- [2021 MATE Floats!](#)
- [Adopt-a-Float Newsletters](#)

**IMPORTANT NOTE: Questions about production demonstrations and design and building specifications should be sent to the [Competition Technical Manager](#). Question, answers, and official rulings will be posted on the [MATE ROV Competition Q&A and Official Ruling Document](#). This allows all companies to see the questions and answers and helps to avoid duplicate questions. That said, please make sure that your question(s) has not already been asked – and answered – before emailing. It is up to the companies to read, comprehend, and comply with ALL rulings posted on the site.**

## **WEIGHT RESTRICTIONS**

In light of some of the environments in which the ROVs will be operating, an ROV weight requirement has been included in the request for proposals (RFP). Lighter vehicles will be given special consideration and vehicles above a certain weight will not be considered. Size of the ROV will be limited by an 85-centimeter cube docking station that the ROV must pilot into.

### ***New for 2023!!!***

All weight measurements will include the vehicle and all tools and components. The weight measurement will NOT include the tether. The following will NOT be included in the weight measurement:

- The topside control system and the tether
- The vertical profiling float
- Any independent sensors if removable from the ROV

Vehicles will be weighed in the on-deck circle 15 to 20 minutes prior to the company's product demonstration run. Note that the vehicle will be weighed before EACH product demonstration run. The weight bonus, if any, will be added to each product demonstration score.

Weight measurements will be conducted using a digital scale. In addition, companies must be able to personally transport the vehicle and associated equipment to the product demonstration station and to the engineering presentation room. ROV systems must be capable of being safely hand launched.

Competition officials will use the following chart to award points for weight:

<b>Weight (in air)</b>	
<b>&lt; 18 kg</b>	<b>+10 points</b>
<b>18.01 kg to 25 kg</b>	<b>+5 points</b>
<b>25.01 kg to 35 kg</b>	<b>+0 points</b>

Vehicles greater than 35 kg in weight will not be allowed to compete in the product demonstration.

### **Weight Protocol**

Only the six designated product demonstration company members will be allowed into the on-deck circle during and after the weigh in. Once a company's vehicle has been weighed, it must remain there until the company moves to its product demonstration station. Companies that detach equipment from the vehicle may not re-install that equipment until the 5-minute set up period. At that time, companies may replace any items that were detached for the measurement, but no new equipment (i.e., equipment that was not included in the weight measurements) may be added to the vehicle. If it is discovered that a company added equipment that was not included in the measurements, the company will not be permitted to compete in that product demonstration run.

Videos showing simulated weight measurements are posted [here](#).

## **PRODUCT DEMONSTRATION**

Companies must launch through a 1-meter square area on the surface, side of the pool. This square will simulate a ship's moon pool/internal launch bay. The vehicles tether MUST travel from the launch station through this 1-meter square at all times. Companies are not required to return any of the items retrieved to the surface, side of the pool through this 1-meter square, but the ROV must launch and its tether travel through this square at all times.

### **TASK 1: Marine Renewable Energy**

#### **UN Sustainable Development Goals:**

**#7 Affordable and Clean Energy**

**#12 Responsible Consumption and Production**

**This task involves the following steps:**

**1.1 Install a floating solar panel array**

- **Position a solar panel array amongst floating wind turbines – 10 points**
- **Moor the panel array to three anchor points – 5 points each, 15 points total**
- **Connect the floating solar panel array to the power grid**
  - **Remove the power port cover – 5 points**
  - **Install the power line connector into the power port – 10 points**

**1.2 Remove biofouling from the foundation and mooring lines of floating wind turbines**

- **Remove 1 to 2 biofouling from turbines – 5 points**
- **Remove 3 to 5 biofouling from turbines – 10 points**
- **Remove 6 biofouling from turbines – 15 points**

**1.3 Pilot into “resident ROV” docking station**

- **Autonomously – 15 points**
- **Manually – 10 points**

**Total points = 70 points**

**Product Demonstration Notes:**

Companies must complete the steps of Task 1.1: Install a floating solar panel array in order. Companies may not skip any steps of this task and continue with further steps of Task 1.1. Companies must complete Task 1.3 Pilot into “resident ROV” docking station as the final task. Once companies have completed Task 1.3, the production demonstration time ends, and no other points may be scored.

**Task 1.1 Install a floating solar panel array**

The steps of this task must be done in order. Companies cannot proceed to the next step until they have successfully completed the previous step. Companies must first position the solar panel array amongst three floating wind turbines. The solar panel array will be floating on the surface, side of the pool at the start of the product demonstration. The solar panel array will be constructed from a triangular piece of corrugated plastic sheeting with PVC extending down into the water from the center and from each corner of the triangle. Flotation will keep the array on the surface of the pool. A small ½-inch end cap will mark the center of the solar panel array.

Three floating wind turbines will be positioned in a triangle in the product demonstration area, with 1.5 meters between each of the three turbines. Two of the turbines will be located parallel to the side of the pool the company launches from, while the third will be located further out from the edge of the pool. The surface side of the three floating wind turbines will be constructed from ½-inch PVC pipe with flotation attached. Propeller blades for the floating wind turbine will be simulated by three 30 cm lengths of corrugated plastic sheeting. All three turbines will be connected by a rope to a ½-inch framework on the bottom. The rope will be just long enough to reach from the floating turbine to the PVC framework on the bottom.

Companies will receive 10 points when they position the solar panel array amongst the three wind turbines. Successfully positioning the solar panel is defined as the end cap in the center of the bucket lid completely within the triangle formed by the three floating wind turbines.

Once the solar panel array has been positioned, companies must moor the panel array to three anchor points located on the bottom of the pool and attached to the PVC framework that holds the floating wind turbines. The anchor points will be #310 U-bolts. The three mooring connectors will be attached to the three ½-inch PVC pipes extending down from each corner of the triangular solar panel array. Each mooring connector will be constructed from ½-inch PVC pipe with a carabineer attached to it. A ¾-inch adapter with Velcro loops inside will hold the connectors in place over the ½-inch pipe. The three mooring connectors will be secured to the solar panel array by ropes. The ropes will be 1.25 times the depth of the pool in length. Companies must remove the three mooring connectors from the array and attach them to the three anchor points on the bottom. Any mooring connector can be attached to any anchor point.

Companies will receive 5 points for each mooring connector successfully attached to the anchor point, 15 points total. Successfully attaching the mooring connection to the anchor point is defined as the carabineer of the mooring connectors clipped to the anchor point U-bolts. Although companies can attach any mooring connector to any anchor point, each mooring connectors must be attached to a different anchor point.

After all three mooring connectors have been attached to the anchor points, companies must connect the floating solar panel array to the power grid. The power connector, also attached to the underside of the solar panel array, must be installed over a power port, located on the bottom of the pool. Companies must first remove the power port cover from the power port. The power port will be constructed from 2-inch PVC pipe and protected with a cover constructed from a 3-inch pipe with a knockout cap inserted into one end. A rope will act as a grab point for the cover.

Companies will receive 5 points for successfully removing the power port cover. Successfully removing the power port cover is defined as the cover no longer in contact with any part of the power connector. The power port cover is considered debris. If it is left on the bottom, not under control of the ROV when mission time ends, companies will be penalized for leaving debris in the pool. Companies may return the cover to the surface, side of the pool or companies may keep the cover on their vehicle. Companies will not be penalized if the power port cover is under control of the vehicle when mission time ends and/or the vehicle is piloted into the docking station.

After removing the power port cover, companies must install the power connector over the power port. Like the mooring connectors, the power connector will be attached to a length of ½-inch PVC pipe sticking down from the center of the array. The power connector will be constructed from 3-inch pipe with ½-inch PVC pipe as a handle and grab point. The receiver side of a 12-volt [inductive coupling power connector](#) will be placed in the center of the 3-inch connector. The power connector will be secured to the floating solar panel array by a wire. Two LEDs will also be incorporated into the power connector.

The power port will be constructed from 2-inch PVC pipe connected to a ½-inch PVC pipe framework. The transmitter side of a 12-volt [inductive coupling power connector](#) will be located at the top of the 2-inch pipe, in a 2-inch knockout cap, and covered with less than 2 mm of epoxy for waterproofing. Wires will connect the inductive coupling transmitter side to a 12-volt power supply on the surface.

**NOTE:** In the real world, the solar panel array would be providing electrical power to the “shore;” however, for safety purposes, the MATE ROV Competition did not design this task with a battery or power supply on the water. The power supply will be located on shore instead of on the solar panel array.

Companies will receive 10 points for successfully installing the power connector over the power port. Successfully installing the power connector over the power port is defined as the power port no longer in contact with the vehicle and the LEDs on the power connector being illuminated by the inductive coupling power connection. The station judge must be able to see the illuminated LEDs.

Additional information on the inductive coupling power connector will be provided in the [Prop Building Instructions](#).

### **Task 1.2 Remove biofouling from the floating wind turbines**

Companies must remove biofouling from the floating wind turbines. There will be two types of biofouling on the floating wind turbines: encrusting marine growth and algal marine growth. Encrusting marine growth will be simulated by a ½-inch PVC cross painted red. A 2 cm x 2 cm square of Velcro loops will be attached to the ½-inch cross. The floating wind turbine will have a 1.0 cm x 0.8 cm square of Velcro hooks attached to it. The Velcro loops on the cross will be attached to the Velcro hooks on the floating wind turbine. The algal marine growth will be simulated with pipe cleaners. The pipe cleaners will have a loop at one end to act as a grab point. The other end of the pipe cleaners will be inserted into holes drilled into the ½-inch PVC pipe of the floating wind turbines. The biofouling, both encrusting and algal, will be found either on the PVC pipe of the floating turbine or on the ropes holding the turbines in place. The biofouling attached to the PVC pipe of the wind turbines will be at least 20 cm below the surface of the water.

Six biofouling will be located on the three floating wind turbines. Companies that successfully remove all six biofouling will receive 15 points. Companies that successfully remove 3 to 5 biofouling will receive 10 points. Companies that remove 1 or 2 biofouling will receive 5 points. Successfully removing a biofouling is defined as the ½-inch PVC cross or pipe cleaners no longer in contact with the PVC pipe or rope of the floating wind turbine. Biofouling is not considered debris and may be left in the pool at the end of the product demonstration time.

### **Task 1.3 Piloting into “resident ROV” docking station**

At the end of the product demonstration run, instead of returning to the surface, side of the pool companies must pilot their ROV into a “resident ROV” docking station. The docking station will be 85 cm meter cubed and constructed from ½-inch PVC pipe with corrugated plastic sheeting for side walls and a roof. As their final product demonstration task, companies must maneuver their vehicle into this docking station and push a button at the back of the station. The button will be constructed from a ½-inch PVC end cap painted red. After entering the docking station, the product demonstration time ends, and companies can no longer attempt tasks or receive points. Companies that need to return items to the surface, side of the pool should do so before docking.

Companies may choose to pilot into the “resident ROV” docking station autonomously or manually.

Companies that choose to pilot into the station autonomously are tasked with creating software that will allow their vehicle to autonomously enter the docking station. Companies will receive 15 points when they successfully pilot autonomously into the docking station. Successfully piloting autonomously into the docking station is defined as the ROV positioned completely outside of the docking station, the company going hands free from the controls, and the ROV moving on its own so that the ROV pushes a button located on the back of the docking station. The station judge must be able to see the ROV push the button to receive points.

Companies may choose to pilot into the docking station manually. Companies will receive 10 points when they successfully dock manually in the station. Successfully docking manually in the station is defined as the ROV under control of the pilot moving so that the ROV pushes a button located on the back of the docking station. The station judge must be able to see the ROV push the button to receive points.

## **TASK 2: Healthy Environments from the Mountains to the Sea**

### **UN Sustainable Development Goals:**

**#13 Climate Action**

**#14 Life Below Water**

**This task involves the following steps:**

#### **Task 2A: Coral Reefs and Blue Carbon**

##### **2.1 Create a 3D model of a diseased coral head**

- **Autonomously**
  - **Create a 3D model of the coral head – up to 30 points**
    - **3D model of the coral head is created – 15 points**
    - **Diameter measurement displayed on the model and within 2 cm – 5 points**
    - **Height measurement is displayed on the model is within 2 cm – 5 points**
    - **Total area of diseased coral is displayed on the model is within 2 square cm – 5 points**
- **Manually**
  - **Measure the dimensions of the coral head – up to 15 points**
    - **Measure the diameter of the coral head within 2 cm – 5 points**
    - **Measure the height of the coral head within 2 cm – 5 points**
    - **Calculate the total area of diseased coral within 2 square cm – 5 points**
  - **Use the dimensions to create a 3D model of the coral head – 5 points**

##### **2.2 Identify reef organisms using eDNA**

- **Collect a water sample from above the coral head – 10 points**
- **Use the eDNA data to identify coral reef fish species – 5 points**

##### **2.3 Administer Rx to diseased corals**

- **Light**
  - **Position the simulated UV light source over the diseased area of coral – 5 points**



- Irradiate the diseased area of coral with simulated UV light – 5 points
- **Probiotics**
  - Place a tent over the diseased area of coral – 10 points
  - Insert a syringe filled with “probiotic” into a port – 5 points
  - Inject a “probiotic” fluid into the tent – 5 points

**2.4 Monitor and protect seagrass habitat**

- Compare images to determine the recovery of a seagrass bed from an anchor scar – 5 points
- Install an Eco-Mooring system to protect seagrass and seahorse habitat – 10 points

**Task 2B: Inland Lakes and Waterways**

**2.5 Reintroduce endangered native Northern Redbelly Dace fry**

- Search two potential sites for invasive predatory fish species to determine which one is safe for release – 5 points each, 10 points total
- Transport the fry to safe release area – 5 points
- Allow the fry to acclimate to local conditions – 5 points
- Release the fry – 10 points

**2.6 Ensure the health and safety of Dillon Reservoir**

- Inspect the buoy ropes for damage – 10 points
- Recover a container from the bottom of the reservoir
  - Determine the lift capability of your ROV – 5 points
  - Lift the container – 10 points
  - Return the container to the surface, side of the pool – 5 points

**2.7 Monitor endangered Lake Titicaca giant frogs**

- Count the number of frogs in a transect
  - Fly a transect – 10 points
  - Count the number of frogs – 5 points
- Install a long-term camera into a designated area on the bottom of the lake – 5 points

**Total points = 170 points**

**Product Demonstration Notes:**

**Task 2.1 Create a 3D Model of a coral head**

Companies must measure the dimensions of the coral and create a 3D model of the coral head. The coral head will be simulated by a colored plastic bowl sitting upside down on a PVC framework at the bottom of pool. Three squares of diseased tissue, simulated by squares of white tape, will be attached to the plastic bowl. These areas of tape will be 36 square cm (6 cm x 6 cm), 16 square centimeters (4 cm x 4 cm), and/or 4 square centimeters (2 cm x 2 cm). Companies choosing to do this task autonomously must use photogrammetry to create a 3D model of the coral head in a CAD program and display the proper diameter and height of the coral head, as well as the total area of the diseased tissue.

Companies may maneuver around the coral head to take photos. Companies may transfer any images from the ROV to a computer or device at the mission station. This transfer does not have to be done autonomously; it can be accomplished "by hand." Companies are allowed to place an object of known

dimensions (ruler) on or near the coral head to assist in the measurements. Note that this object of known dimensions would count as debris if it is not under control of the ROV or removed from the pool by the end of product demonstration time.

Companies will receive up to 30 points for modeling the 3D coral head autonomously. Companies that successfully model the coral head as a 3D design will receive 15 points. Successfully modeling the coral head autonomously is defined as the coral head displayed as a 3D design on a screen at the product demonstration station. All three diseased tissue areas must be included on the image. The image should be able to be rotated so that the station judge can view it from any angle.

Companies must display the following three dimensions of the coral head on their 3D design: the diameter of the coral head, the height of the coral head, and the total area of the diseased tissue. Companies will receive 5 points for successfully displaying each of these three dimensions, 15 points total. Successfully displaying the diameter and height of the coral head is defined as the diameter and height measurement included on the model and being within 2 cm of the true length. Note that the height should be from the bottom of the pool to the topmost point of the coral head. Successfully displaying the total area of the diseased coral tissue is defined as the total area included on the model and being within 2 square cm of the actual area of the diseased coral.

Alternatively, companies may choose to measure and model the coral head manually. Companies that manually measure and model the coral head must first measure the dimensions of the coral head.

Companies must measure the diameter and height of the coral head, as well as measure the diseased tissue area. Companies will receive 5 points for successfully measuring the diameter and height and the area of diseased coral, 15 points total. Successfully measuring the diameter and height is defined as the company measurement being within 2 cm of the true length. Successfully measuring the diseased area of the coral is defined as the company's measurements and calculation of the diseased tissue area being within 2 square cm of the actual area of the diseased coral. Companies must show the station judge their measurement or explain how they are estimating the measurement. Companies may not guess at the measurements.

Companies should then create a 3D model of the coral head in a CAD or other program. Companies may input their measurements manually into a CAD or other program and create their 3D model. The diameter, height, and total area of diseased coral should be included, even if those measurements were incorrect. Companies will not receive the points for properly measuring the dimensions of the coral head but can still receive points for modeling the coral head with the measurements taken. All three diseased tissue areas must be included on the model.

Companies will receive 5 points for successfully modeling the 3D coral head manually. Successfully modeling the coral head is defined as the image of the coral head displayed as a CAD model on a screen at the station and the three dimensions (diameter, height, and total area of diseased coral), included on the model. The 3D model should be able to be rotated and viewed from any angle. All three dimensions must be included and displayed on the image, even if those dimension measurements were incorrect.

### **Task 2.2 Identify reef organisms using eDNA**

Companies must first collect a water sample from inside a container. A 1 liter [soft water bottle](#) will be suspended inside a 2-gallon bucket. A ¾-inch male adapter will be glued to the mouth of the water bottle and penetrate through a hole in a 2-gallon bucket lid. A ¾-inch coupling will be screwed onto the adapter to secure it to the bucket lid and into the 2-gallon bucket. The soft water bottle will be filled with salty water. [Plastic cling wrap](#) will cover the top of the coupling to prevent the salty water from mixing with the pool water. Companies must penetrate through this plastic wrap and collect 50 milliliters of water from inside the soft water bottle.

Companies will receive 10 points for successfully collecting a water sample. Successfully collecting a water sample is defined as 50 milliliters of salty water being returned to the surface, side of the pool. Companies may pump the water inside the soft water bottle all the way to the surface and collect it there, or companies may pump the water inside the soft water bottle into a container on their vehicle and return that container to the surface, side of the pool. The station judge will verify the salinity of the water obtained with a hydrometer.

Note that companies are not actually processing the water sample to extract eDNA; that process would be done in a shipboard or shore-based laboratory but would result in eDNA code sequences described below.

Once the water sample has been successfully collected, companies will receive a laminated sheet with three eDNA code sequences representing DNA base pairs on the Cytochrome Enzyme 1 gene, or CO1 gene. Companies must compare the eDNA code sequences received to those of known coral reef fish species. The Coral Reef Fish Species Handbook will have a list of ten known coral reef fish species and their CO1 gene DNA code sequences. Companies that successfully identify the three coral reef fish species from their eDNA code sequences will receive 5 points. Successfully identifying the coral reef fish species is defined as one company member identifying, by common name and genus/species, all three of the unknown eDNA samples. Companies must correctly identify all three unknowns to receive points. A link to the Coral Reef Fish Species Handbook can be found under the [PRODUCT DEMONSTRATION RESOURCES](#) section of this manual.

### **Task 2.3 Administer Rx to diseased corals**

Companies must irradiate a diseased area of the coral with simulated UV light. A photoresistor and 1-inch coupling and end cap will simulate the diseased area. The 1-inch end cap with a coupling attached will be located next to the coral head. A 5 mm photoresistor will be positioned at the bottom of the end cap; the leads of the photoresistor will be soldered to a set of wires that run to a multimeter at the mission station. The photoresistor and wires will be fully waterproofed. The MATE ROV Competition will supply the multimeter at the surface.

Companies must first position their UV light source over the diseased area, then irradiate the diseased area of coral with a simulated UV light. Companies will receive 5 points for successfully positioning the simulated UV light source over the diseased area of coral. Successfully positioning the simulated UV light source over the diseased area of coral is defined as covering the end of 1-inch coupling and

blocking external light from entering the coupling and illuminating the photoresistor. With minimal light entering the coupling, the resistance reading on the surface should increase. The station judge should be able to see a change in resistance on the surface multimeter.

While their simulated light source is still covering the 1-inch coupling, companies must illuminate the photoresistor. Companies will receive 5 points when they successfully irradiate the diseased area of coral. Successfully irradiating the diseased area is defined as the company's light illuminating the photoresistor at the bottom of the 1-inch coupling and end cap. With light illuminating the photoresistor, the resistance displayed on the multimeter on the surface should decrease. The station judge should be able to see a decrease in resistance on the surface multimeter.

Companies are responsible for building a light source (non-UV) that can both cover the 1-inch coupling so that little to no light enters the coupling and provide its own source of light to illuminate the photoresistor. Companies should not use actual UV light; the spectral peak for these photoresistors is 540 nm. Also note that this light source is NOT a non-ROV device and therefore may not use onboard batteries. Companies must power this light source from ROV power.

Companies must also place a tent over the coral head, insert a syringe into a port, and inject a "probiotic" fluid into the tent. The tent will be constructed from a framework of ½-inch PVC pipe with corrugated plastic sheeting as walls. 1 ½-inch pipe at the top of the tent will serve as a port to insert a syringe and tubing and inject the probiotic fluid.

Companies must first place a tent over the diseased area of coral. The tent will be located on the surface, side of the pool at the start of the product demonstration. Companies will receive 10 points when they successfully place the tent over the diseased area of coral. Successfully placing the tent is defined as the base of the tent against the bottom of the pool, completely covering the plastic bowl of the coral head. No part of the tent should be propped on top of the coral head.

Once the tent has been successfully placed, companies must insert a syringe into the port at the top of the tent. A syringe will be secured inside a length of pipe with couplings and located at the surface, side of the pool at the start of the product demonstration. Colored tape will be wrapped around the bottom end of the syringe. Companies may not place the syringe inside of the port prior to placing the tent. Companies must successfully place the tent, then insert the syringe into the port. Companies will receive 5 points for successfully inserting the syringe into the port. Successfully inserting the syringe into the port is defined as the colored tape wrapped around the bottom end of the syringe completely within the PVC pipe of the port. The plunger of the syringe must be fully extended, it must not be pushed in.

Once the syringe has been successfully inserted into the port, companies must inject a "probiotic" fluid into the tent. The "probiotic" fluid will be simulated by pool water. Companies will receive 5 points when they successfully inject the fluid into the tent. Successfully injecting the fluid into the tent is defined as pushing the plunger of the syringe while the syringe is still in the port at the top of the tent. Prior to injecting the fluid, the station judge must see that the plunger is fully extended. To receive

points for injecting the fluid, the judge must see that the plunger is fully pushed in. The syringe must remain inserted into the port during the entire time that the fluid is being injected.

#### **Task 2.4 Monitor and protect seagrass habitat**

Companies must compare two images to determine the recovery of a seagrass bed from an anchor scar. The images of an actual seagrass bed will be simulated by an 8x8 grid with green boxes (seagrass is present) and white boxes (no seagrass is present). An image of the seagrass bed from 3 months prior will be located at the mission station. The image simulating the current seagrass bed will be located on a laminated sheet on the bottom of the pool. Companies must determine the recovery of the seagrass bed by comparing how many squares on the 8x8 grid have changed from white to green (seagrass recovery) or green to white (seagrass decrease).

Companies will receive 5 points for successfully determining the recovery of the seagrass bed from an anchor scar. Successfully determining recovery is defined as informing the station judge of how many squares have recovered (turned from white to green) between the prior image and the current image in the water, or how many squares have decreased (turned from green to white) between the prior image and the current image in the water. If there has been no change, companies should inform the judge that zero squares have changed.

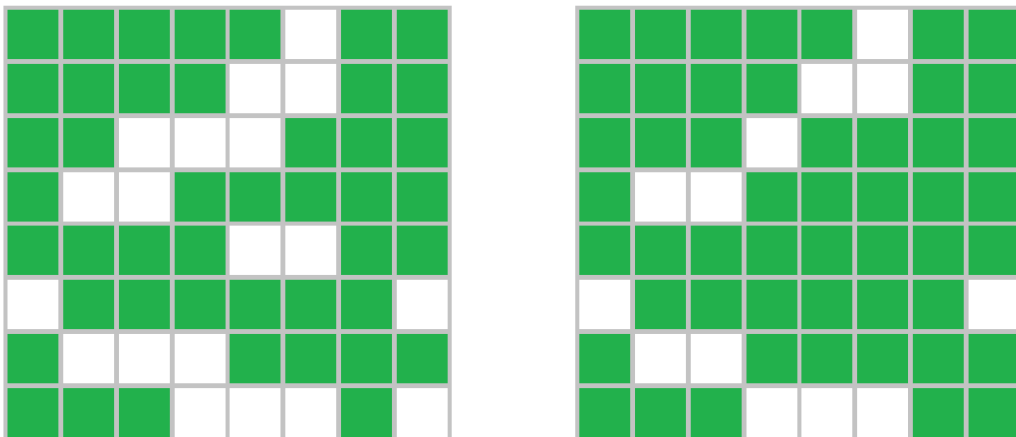

The image on the left is the image from 3 months prior. The image on the right is the current image from the bottom of the pool. Companies would report to the station judge that six squares of seagrass have recovered from the image taken 3 months prior.

Images will either show only recovery (white squares that are now green), no change (no difference in any squares), or decrease in seagrass (green squares turned to white). Images will not have some squares that have changed from green to white and some squares that have changed from white to green.

Companies must install an Eco-Mooring system to protect the seagrass and seahorse habitat. The base of the Eco-Mooring will be “installed” on the bottom of the pool. The base will be constructed from 2-inch PVC pipe attached to a ½-inch PVC pipe base. The Eco-Mooring will be on the surface, side of the pool at the start of the product demonstration. The Eco-Mooring will be constructed from ½-inch PVC pipe. Companies must install the Eco-Mooring into the base and once installed, rotate the Eco-

Mooring 720° to simulate securing it into the sediment. Companies will receive 10 points for successfully installing the Eco-Mooring. Successfully installing the Eco-Mooring is defined as the mooring inserted into the base, turned 720° while in the base, and then released, no longer in contact, with the vehicle. Companies may turn the Eco-mooring either 720° clockwise or 720° counterclockwise.

### **Task 2.5 Reintroduce endangered native Northern Redbelly Dace fry**

Companies must first search two potential sites for invasive predatory fish species to determine which site is safe for release. The two potential sites will be constructed from ½-inch PVC pipe and will be spaced 1 meter apart. Green foam sheeting and vertical lengths of PVC pipe will be added to the potential sites to simulate a natural habitat. Also included in each potential site will be two fish. One site will have predatory fish; one site will have fish harmless to the Northern Redbelly Dace. Fish will be simulated by laminated images of the specific fish. Companies must land in the 1-meter section between the two potential release sites and examine each potential site. Companies must compare the fish seen at each site to those in the Northern Redbelly Dace release handbook and determine whether they are or are not predators of the Northern Redbelly Dace. Both potential release sites must be examined, and both the safe and unsafe sites identified. Companies will receive 10 points for successfully searching the two sites for invasive predatory fish species, 5 points each for each site. Successfully searching the two sites is defined as the vehicle positioned on the bottom in the 1-meter area between the potential sites and showing the station judge that one site contains predatory fish and is not safe for release, and the other site does not contain predatory fish and is therefore safe for releasing. Companies must show the judge the fish in each site. Companies cannot show the station judge fish from one site only and infer that the other site has different fish. The vehicle qualifies as being positioned between the potential sites if any part of the vehicle is touching bottom within the area between the potential release sites.

Companies must transport the fry to the safe release area. Companies are required to create a container to transport the fry; companies may not carry the fry directly in a gripper. Companies can create a container mounted to their ROV, or companies can create a container that can be carried down in a gripper and released from the ROV. Northern Redbelly Dace fry will be simulated by [rubber fishing lures](#) whose hooks have been removed. Three fry will be available at the mission station and can be placed inside the company's container during the 5-minute set up period.

Companies will receive 5 points when they successfully transport the fry to the safe release area. Successfully transporting the fry to the safe release area is defined as the container with the fry, or the ROV with the fry onboard, within the safe release area and within 50 cm from the bottom of the pool. One vertical length of PVC pipe in the safe area will be 50 cm tall. Companies may carry the fry down prior to determining which is the safe release area but will only receive points for transporting the fry after the safe area has been identified.

Companies must allow the fry time to acclimate to local conditions. The container with the fry, or the ROV with the fry onboard, must remain within the safe release area for 20 seconds. Companies will receive 5 points for successfully acclimating the fry to local conditions. Successfully acclimating the fry to local conditions is defined as any part of the container, or any part of the ROV with the fry on board, within the safe area, no more than 50 cm from the pool bottom, for 20 seconds. The entire container or

ROV does not need to be within the safe area. The container or the ROV with the container on board must be within the safe area for 20 continuous seconds. If the container or ROV drifts completely out of the safe area, the 20 second timer will restart. Companies are allowed to drop their container in the safe area and move on to other tasks.

Once the fry have acclimated to local conditions, companies must release the fry into the safe area. Companies will receive 10 points when the fry are successfully released. Successfully releasing the fry is defined as all three fry on the bottom of the pool within the safe area. Partial points will not be given if some fry land within the safe area and some land outside the safe area. The station judge must see all three fry on the bottom within the safe area to receive points.

Companies are allowed to create a powered container for releasing the fry into the designated safe area. This container may not have thruster motors or cameras but may be powered to open and release the fry into the designated safe zone after the ROV has placed it in the safe area and the fry have acclimated. This powered container would be considered a non-ROV device. A 12-volt power source will be available at the surface product demonstration station. See [3.3.1 Non-ROV Device Power Specifications](#) for additional information.

If a company chooses to transport the fish in a container that is dropped into the safe area, that container would be considered debris. The container must be removed from the pool or collected off the bottom under control of the ROV when mission time ends to avoid penalty points for leaving debris in the pool. Companies may use a line or tether to pull this container to the surface by hand. If the container is still attached to the ROV, companies may not pull it and the ROV. Pulling the ROV would constitute a penalty.

### **Task 2.6 Ensure the health and safety of Dillon Reservoir**

Companies must inspect a buoy rope for damage. A [rope](#) will run from a weight on the bottom to a float on the surface. The rope will have ten [2-inch letters](#) (A through J) adhered to corrugated plastic sheets attached to it. No letter will be within 15 cm of the surface of the pool or 15 cm from the bottom of the pool. Companies must pilot their vehicle along the rope and show the judge all ten letters. Companies that successfully inspect the rope will receive 10 points. Successfully inspecting the buoy rope is defined as the station judge able to see and identify all ten letters. Companies must be close enough for the station judge to identify the letters on one of their video cameras.

Companies must also remove a heavy container from the bottom of the pool. Prior to the competition, companies must determine the lift capability of their ROV. Companies must test their ROV and determine the amount of upward force that it generates. Companies should include all lift factors incorporated into their ROV, including thrusters, variable buoyancy systems, etc. Lift mechanisms not directly incorporated into the ROV (independent lift bags, etc.) should not be included in the determination. Companies may want to test motor thrust at variable voltages (See ELEC-002) to provide multiple lift capability values. Companies using vectored vertical thrusters must calculate for the vectored angles. Companies should compile a document detailing their lift capability, in Newtons, and include descriptions of any tests performed. This document is limited to one-page, single-sided. Companies will receive 5 points when they provide their lift capability document to the station judge.

Companies must show the station judge their lift capability document prior to lifting the container from the bottom.

Companies must lift the container from the bottom of the pool. The container will be constructed from 4-inch pipe with a U-bolt attached as a grab point. The weight, in water, of the container will be posted at the mission station. Companies are not required to lift the container only with their ROV thrust. If the weight of the container exceeds the lift capability of the ROV, companies may use lift bags to lift the container to the surface. Companies are not allowed to attach a line to the container and lift it by hand or from a shore-based or surface-based lift mechanism. The ROV must lift the container or attach a mechanism, such as a lift bag, to the container and fill it with air. Companies will receive 10 points when they have successfully lifted the container to the surface. Successfully lifting the container to the surface is defined as the ROV or lift bag breaking the surface of the pool with the container under control of the ROV or attached to the lift bag.

The container will weigh less than 120 Newtons in water.

Companies must return the container to the surface, side of the pool. Companies must use their ROV to push the container to the side of the pool. Companies may not pull the container by hand or use some other shore-based mechanism to pull the container in. Companies will receive 5 points when they successfully return the container to the surface, side of the pool. Successfully returning the container to the surface, side of the pool is defined as the container being removed from the water and placed on the pool deck.

### **Task 2.7 Monitor endangered Lake Titicaca giant frogs**

Companies must fly a transect line over an area and count the number of frogs. The area will be simulated by a ½-inch PVC pipe rectangle 3 meters long by 0.5 meters wide. The 3-meter lengths of PVC pipe that make up the “top” and “bottom” of the area will be painted blue. The 0.5-meter “ends” of the transect area will be painted black.

An additional 3-meter length of PVC pipe will be located 40 cm from the top and bottom of the search area. These additional lengths of pipe will be painted red. The 0.4-meter “ends” of these transect areas will be painted yellow. The transect area will be located on the bottom of the pool.

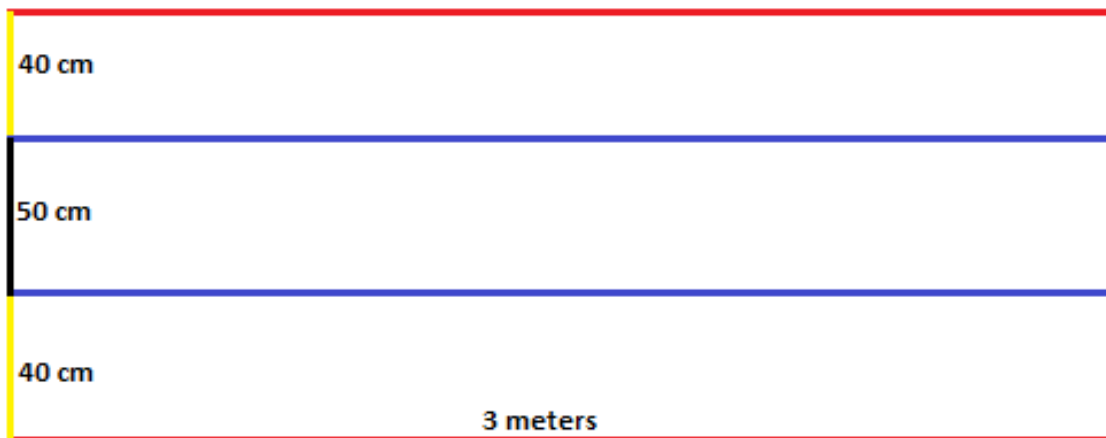



A diagram of the transect area. The blue, red, yellow, and black lines are painted ½-inch PVC pipes.

Companies must fly a transect line over the area, displaying the video image of the transect on a display screen for the station judge. Companies will receive 10 points for successfully flying a transect. Successfully flying a transect over the area is defined as starting at one end of the transect and moving to the other end of the transect. Starting at one end of the transect is defined as the ROV directly above the black length of PVC pipe on either end of the transect.

The ROV must also remain at a certain height over the transect area. While flying the transect, both blue painted PVC pipes must be in the video display at all times and neither red pipe may be visible in the video display. If any section of red pipe is seen in the video display, or both blue pipes are not seen in the video display at all times, the ROV has failed to successfully fly the transect.

A video showing successful and unsuccessful flying of the transect line can be seen [here](#).

Companies must also count the number of Lake Titicaca giant frogs in the transect area. The giant frogs will be simulated with [plastic frogs](#). All the frogs will be within the 3-meter x 50 cm rectangle created by the PVC pipe painted blue and black. No frogs will be outside of this area. Companies will receive 5 points for successfully counting the number of giant frogs in the transect area. Successfully counting the number of giant frogs in the transect area is defined as informing the station judge of how many frogs are counted, and that number matching exactly with the actual number of frogs in the transect area.

Companies must install a long-term camera to monitor the giant frogs into a designated area. The camera will be simulated by 1-inch PVC pipe attached to a 1/2-inch PVC pipe framework. The designated area will be a 40 cm square constructed from orange colored ½-inch PVC pipe. The camera will be located on the surface, side of the pool at the start of the product demonstration. Companies will receive 5 points when the camera is successfully installed into the designated area. Successfully installing the camera into the designated area is defined as the base of the camera framework completely within the pipe of the designated area. The base of the camera may not be on top of any portion of the ½-inch PVC pipe of the designated area.

### **TASK 3: *MATE Floats! 2023***

#### **UN Sustainable Development Goal:**

#### **#13 Climate Action**

**This task involves the following steps:**

#### **3.1 Design and construct an operational vertical profiling float**

- **Prior to the competition, design and construct an operational vertical profiling float – 5 points**
- **Float communicates with the mission station prior to descending – 10 points**
- **Float completes up to two vertical profiles –**
  - **Vertical profile 1**
    - **Float completes first vertical profile – 10 points**

- Float communicates time to mission station – 10 points
  - Vertical profile 2
    - Float completes a second vertical profile – 10 points
    - Float communicates time to mission station – 15 points

**Total points = 60 points**

**Product Demonstration Notes:**

**Task 3.1 Design and construct an operational vertical profiling float**

Prior to the competition, companies must build a float capable of completing a vertical profile (i.e., traveling from the surface to the bottom and back to the surface) and communicating data to the mission station. Companies must design their float with a buoyancy engine. A [buoyancy engine](#) moves fluid from inside the float to outside the float, displacing seawater and changing the density of the float. The float must also be capable of communicating data to a receiving device (i.e., the receiver) located at the surface at the mission station. The company is responsible for designing and constructing both the transmitter on the float and the receiver that displays the data at the mission station.

Companies will receive 5 points for designing and building a float. Companies must submit a one-page Non-ROV device document outlining their float design, detailing its operation, including the design of its buoyancy engine, and demonstrating that it does not violate any safety rules. This document must also detail how the float communicates with the company’s receiver at the mission station. This Non-ROV device document must be submitted in advance of the competition.

Companies competing at a regional may or not be required to submit this document. [Contact your regional coordinator or visit your regional contest’s website](#) to determine if you must submit your float design document prior to the competition. See DOC-004 for more information. IF REQUIRED BY THE REGIONAL COMPETITION, COMPANIES MUST SUBMIT THEIR FLOAT DOCUMENTATION OR THEY WILL NOT BE RECEIVE POINTS FOR BUILDING THE FLOAT. Companies MUST present a copy of the float documentation to the station judges.

Companies will deploy their float in a designated location. Once the float has been deployed, it must communicate to the receiver located on the surface at the mission station. Companies are responsible for constructing both the transmitter on the float and the receiver at the mission station. Companies should design their float so that the transmitter can be maintained high enough above the surface of the water to communicate with the mission station.

The float must communicate (i.e., transmit) the following data to the mission station:

- company number (provided by MATE a few weeks prior to the World Championships)
- the current [Coordinated Universal Time](#) (UTC)

NOTE: MATE is requiring WHAT data is transmitted (i.e., company number and UTC). Companies must determine HOW to transmit that data and should consider that there will be other companies transmitting data at same time.

The float must transmit the UTC data to the receiver; the receiver should not access the Internet, nor should it receive transmissions from any source other than the float. The transmission should refresh and advance the time displayed every second.

Companies will receive 10 points when their float successfully transmits their company number and the UTC to the receiver at the mission station upon deployment. Successfully transmitting the information is defined as the station judge seeing the company number and UTC (displayed in hours, minutes, and seconds) on the receiver after the float has been deployed. The data can be displayed at any time after deployment, but prior to the float completing its first vertical profile. The data should be transmitted constantly provided the float is on the surface of the water.

The float should attempt to complete two vertical profiles. A vertical profile is defined as any part of the float on or above the surface, descending in the water column until any part of the float touches the bottom, then ascending to and breaking the surface once again. Companies must use a buoyancy engine to move their float through the water. A buoyancy engine is defined as moving air or liquid from inside the float to outside the float, changing the volume and thus the density of the float. Companies will receive 10 points for completing their first vertical profile.

After the first vertical profile has been completed and the float is still at the surface, the float must communicate the company number and the UTC. Companies will receive 10 points when the float successfully communicates to the mission station. The float MUST have completed one vertical profile to receive points for transmitting data to the receiver. Successfully transmitting data to the receiver is defined as the station judge seeing the company number and UTC (displayed in hours, minutes, and seconds) on the receiver at the mission station. If the float descends before the station judge verifies the data, companies will not receive points for transmitting data, but will receive points for a successful vertical profile. The data should be transmitted constantly provided the float is on the surface of the water.

The float should then attempt to complete a second vertical profile. Companies will receive 10 points for completing their second vertical profile.

After the second vertical profile has been completed, the float must communicate the company number and the UTC. Companies will receive 15 points when the float successfully communicates to the mission station. The float MUST have completed a second vertical profile to receive points for transmitting data to the receiver. Successfully transmitting data to the receiver is defined as the station judge seeing the company number and UTC (displayed in hours, minutes and seconds) on the receiver at the mission station. If the float descends before the station judge verifies the data, companies will not receive points for transmitting data, but will receive points for a successful vertical profile. The data should be transmitted constantly provided the float is on the surface of the water.

If the float fails to communicate to the mission station after its first or second vertical profile, it can continue to complete vertical profiles until it is successful. For example, if the float completes its first vertical profile but fails to communicate to the mission station before descending for its second vertical profile, companies would receive points for a vertical profile, but would not receive points for

communication. After completing a second vertical profile, if the float communicates successfully with the surface station, companies would receive points for their second vertical profile and would receive points for their first communication. If the float then completes a third vertical profile and successfully communicates to the mission station, companies would not receive any additional points for the third vertical profile, but they would receive points for their second communication attempt.

The float must be less than 1 meter in overall height. The float may not have a diameter/length/width greater than 18 cm.

The float must move independently from the ROV. The float must operate independently; it may not be connected to the shore by a tether nor can the ROV interact with the float after deployment. The float will operate as a non-ROV device (see 3.3.1 Non-ROV Device Power Specifications in the competition manual) for additional rules on powering a non-ROV device.

## PRODUCT DEMONSTRATION RESOURCES

[Coral Reef Fish Species Handbook](#)

[Northern Redbelly Dace Release Handbook](#)

**NOTE for 2023!!!**

## PRODUCT DEMONSTRATION RESPONSIBILITIES

Companies are responsible for designing, building, and bringing their own operational vertical profiling float. Companies must also design and bring any tools or devices to complete the required MATE product demonstration tasks.

Companies are permitted to create a basket to collect multiple product demonstration items. Any collection basket **MUST** be included in size and weight measurements. A collection basket is considered debris if still in the pool and not under control of the ROV when product demonstration time ends. Any collection basket must be deployed and returned by the ROV; it may not be pulled to the surface by hand or a surface device.

The MATE ROV Competition will provide all of the remaining product demonstration items.

## PART 2: PRODUCT DEMONSTRATION PROP BUILDING INSTRUCTIONS & PHOTOS



Obstacles



Creativity



Critical Thinking  
Problem Solving



Intellectual  
Development



System Design



Vehicle Design,  
Buoyancy, Propulsion



Sensors, Payload,  
Tools

The [Product Demonstration Prop Building Instructions & Photos](#) will be released with, but separate from, this competition manual.

## PART 3: VEHICLE DESIGN & BUILDING SPECIFICATIONS



### 1.0 GENERAL

Questions about production demonstrations and design and building specifications should be sent to the [Competition Technical Manager](#). Question, answers, and official rulings will be posted on the MATE ROV Competition [Q&A and Official Ruling Document](#). This ensures that all companies can view the questions and answers and helps to avoid duplicate questions. That said, please make sure that your question(s) has not already been asked – and answered – before emailing. When emailing their question, companies should reference

- Any specific specification or rule (e.g. ELEC-002E)
- Competition class

Conventions: All values contained in this document are threshold values unless specifically stated otherwise. All water depths are given in meters (m). All dimensions and measurements utilize SI units.

EXPLORER class companies participating in a regional competition should contact their [regional coordinator or visit their regional contest's website](#) to find out any specific requirements for your regional.

### 2.0 SAFETY

Safety is the competition's primary concern and guiding principle. Any system that is deemed unsafe by competition officials will not be allowed to compete. If a safety concern is identified during the initial inspection, companies are permitted to modify their system and have it re-inspected. Companies are permitted to have their vehicle re-inspected twice. If a company fails to pass its third and final safety inspection, it is disqualified from the underwater competition portion of the event. There are NO APPEALS once an ROV has been disqualified.

#### **NOTE for 2023!!!**

MATE ROV Competition safety inspectors will be reinforcing the competition's emphasis on safety. Wiring discipline/workmanship (ELEC-023E) and strain relief at both ends of the tether (ELEC-024E) will be areas of particular emphasis. **Companies that do not meet these safety standards will not be permitted to compete in the in-water events.** Additional examples of wiring workmanship will be included in the [MATE ROV Competition Safety Inspection Tutorial](#).

Examples of safety violations from previous ROV competitions include:

- Companies used equipment that did not participate in and/or pass safety inspection
- The electrical SID included in the technical documentation did not show a main fuse.
- The ROV used pneumatics, but the technical documentation did not include a pneumatics diagram or pneumatic specifications.
- The ROV used pneumatics, but the company had not passed the fluid power quiz.

## 2.1 Job Site Safety Analysis

Each member of the company is encouraged to read [Oceaneering Americas Region HSE Employee Handbook](#), with emphasis placed on the following chapters.

Chapter 1 - Housekeeping

Chapter 9 - Hand Safety

Chapter 11 - Lifting and back safety

Chapter 12 - PPE

Chapter 17 - Tool Safety

Chapter 24 Electrical Safety

Chapter 29 - Employee Observation Program

Chapter 33 - JSEA

Chapter 37 - Working at Other sights

### Job Site Safety Analysis (JSAs)

For companies advancing to the World Championship, 10 points can be earned by creating a JSA and submitting it along with (but as a separate document from) the [Technical Documentation](#).

A **JSA** describes job tasks in step-by-step fashion, identifies associated hazards at each step, and outlines proper hazard controls that minimize the risk of injury or illness to the individual(s) performing that task. JSAs are used extensively by the offshore industry.

For more information and examples, companies can visit the following web sites:

- <http://ehs.berkeley.edu/how-do-i-write-and-update-job-safety-analysis-isa>
- [www.safetyworksmaine.com/safe\\_workplace/safety\\_management/hazard\\_analysis.html](http://www.safetyworksmaine.com/safe_workplace/safety_management/hazard_analysis.html)

**POTENTIAL HAZARDS**

DESCRIBE JOB STEP <small>(List the natural steps of the job. Do not make the steps too broad or too fine)</small>	POTENTIAL HAZARDS <small>(What are the potential hazards identified at this part of the job steps)</small>	RECOMMEND RISK CONTROL MEASURES <small>(describe how the identified hazards can be eliminated or reduced)</small>	RESPONSIBLE PERSON (S) <small>(Implementing control)</small>	INITIAL <small>(Of the responsible person/s)</small>
Toolbox Talk	Miscommunication	<p><b>ANYONE can call ALL STOP at any point if an unsafe condition /act is perceived/observed.</b></p> <p><b>Cell phone use is PROHIBITED in test area while testing!</b></p> <p>Ensure all participants are aware of procedures and roles within the procedure and sign JSEA acknowledging this.</p> <p>Ensure that all participants are wearing correct PPE (safety glasses, safety shoes, gloves, and hard hats if crane ops are being performed)</p> <p>Ensure participants/witnesses are wearing adequate clothing for weather conditions and to take breaks whenever necessary.</p>		
Hydraulic Function Testing	<p>Stored/Trapped Energy: Up to <b>12,000 PSI</b></p> <p>Environmental Discharge</p> <p>Tubing/Hose Failure</p> <p>Line of Fire</p>	<p>Ensure all functions have pressure/flow reduced to 0 PSI when not being actively function tested.</p> <p>Ensure each circuit is setup correctly before increasing pressure.</p> <p>Ensure Vent hoses are properly connected to fluid containment reservoir.</p> <p>Ensure all hoses are whip checked before coming up on pressure.</p> <p>Ensure valves and actuators are in proper configuration before testing.</p> <p>Ensure relief valves are set to relieve at the proper setting.</p>		

Example JSA task items courtesy of Oceaneering International

**NOTE for 2023!!!**

Companies should focus their JSA on their deck/dive operations only. **Shop safety and tool safety for building the ROV is extremely important but does not belong in this JSA.** The submitted JSA should focus information on potential hazards and recommended risk control measures of a company’s pool side operations. This JSA should cover topics such as:

Deck Ops/Launch and Recovery:

- Entering/exiting the pool deck area
- System set up
- Power up checks
- Pool side operations
- System breakdown

**2.2 Safety Pre-Inspection**

A safety pre-inspection will be completed before competition day. Companies will submit the following documentation to the MATE ROV Competition. EXPLORER teams attending regionals should submit their required documentation to their regional coordinator. Regionals may not require all of these documents. Contact [your regional coordinator or visit your regional contest’s website](#) to determine the required documents as well as the date and proper format for submission. Safety pre-inspection document submissions will include the following:

- Technical documentation
- Company spec sheet
- SID [Electrical, Pneumatic & Hydraulic as utilized]
- Non-ROV device design document (if used)
- Non-ROV device SIDs (if used)
- Company safety review

See 2.2.1 Safety documentation requirements below for more information.

Once received, safety inspectors will conduct an **initial safety and documentation review** to identify potential safety violations. This review will be worth 20 points. Companies with violations will be notified via e-mail. Once notified, companies must:

- a. Respond acknowledging receipt.
- b. Layout a plan to address the violation.
- c. Submit new documentation if required.

Safety inspectors will also compile a list of the safety violations and publish them to the competition website. This is not done to “call out” or embarrass companies in any way. It is to emphasize the fact that EVERYONE is responsible and accountable for ensuring a safe, successful event. It also allows the company to correct the safety violations before arriving at the World Championship.

### **2.2.1 Safety documentation requirements**

Unless stated otherwise, each document **MUST** be submitted separately. In addition to the SID included in the technical documentation, an individual SID must be submitted for the initial safety inspection. The company safety review should **NOT** refer to systems shown in a submission video or detailed in the technical documentation.

DOC-001: SID Electrical: This must be an electrical diagram for all ROV systems. One section should focus on the systems above the waterline, and one section should focus on systems on the ROV (below the waterline). The SID:

- Should not exceed one 8.5” x 11” page in length (both above and below water sections, as well as any other information, should be on one page). Printed documents must be sized to fit on one side of the printed paper.
- Must be drawn with a CAD (computer assisted drawing) program. Hand drawn figures are not permitted.
- All symbols used should be standard symbols as specified by ANSI, NEMA or IEC.
- The SID must include a FUSE SYMBOL using an ANSI, NEMA or IEC symbol.
- The SID must not be component level schematics, but a higher-level interconnection block type diagram. Do not include individual pins on a board; the SID is a higher-level diagram.



- Fuse calculations must be included on the SID.

The following ANSI and IEC fuse symbols are all acceptable for MATE documentation.

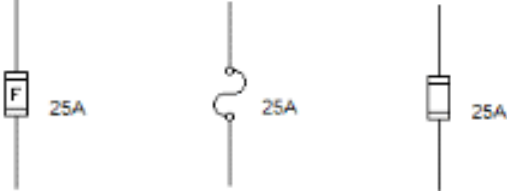
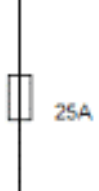
Item	ANSI	IEC
FUSE		

An example of an acceptable SID can be found here:

- EXPLORER example: [2018 Eastern Edge SID](#)

DOC-002: SID Fluid Power: Companies using fluid power **MUST** include a fluid power diagram using industry standard symbols, showing all items, regulators, and control valves. The diagram must document the components on the surface and the components located onboard the ROV. Fluid power diagrams must use ANSI, NEMA or IEC symbols. The fluid power diagram must also be drawn with a CAD program and should be a one 8.5" x 11" page diagram. The fluid power diagram may be included on the main electrical SID or as a separate one-page document.

DOC-003: SID Non-ROV Device: Companies utilizing an independent sensor or other electrically powered, non-ROV device to complete a product demonstration task must submit a SID for this device. The *MATE Floats!* vertical profiling float, if designed and used at the competition, is considered a non-ROV device. A powered Northern Redbelly Dace release container is also considered a non-ROV device. This diagram must be completed to the specifications listed in DOC-001. The non-ROV device SID may be included on the main electrical SID or as a separate one 8.5" x 11" page document. Two separate pages may be used for two different non-ROV devices. Companies must include fuse calculations on their non-ROV device SID. Companies not designing and building a vertical profiling float or powered release container should state so in their Company Safety Review.

DOC-004: Non-ROV device design: Companies will be required to submit a one page written and photographic description of their non-ROV device. This document must contain a photo or diagram of your non-ROV device. This document **MUST** include the type of battery used.

**NOTE for 2023!!!**

Any electrical or fluid powered device on the ROV **MUST** be documented on a SID. Depending on the type of device, it may be on the main ROV SID, an independent sensor SID, a Non-ROV device SID, or a Fluid SID. Any such device not represented on a SID cannot be used in the competition.

DOC-005: Company safety review: EXPLORER companies submitting a company safety review MUST show compliance with the following specifications:

- SBS50 Anderson Powerpole connectors are the main point of connection to the MATE supply (ELEC-010E).
- A properly sized Littelfuse is within 30 cm of the main point of connection to 48-volt power. The company must use a ruler to show this distance (ELEC-001E).
- Fuse calculations (ELEC-008E).
- The inside of the control box does not have exposed wiring (ELEC-017E), the control box is neatly laid out with attention to workmanship (ELEC-022E), a separation and identification of 120VAC wiring from DC and control voltages (ELEC-023E). If AC wiring is not used in the control box, include a statement saying no AC is used. Note: Companies using a computer or laptop should state that they are using a laptop and include the type of controller used (Joystick, Xbox controller, etc.).
- The tether leading to the control system has adequate strain relief (ELEC-024E).
- The tether leading to the ROV has proper strain relief (ELEC-024E).
- If hydraulics / pneumatics are used that the company has passed the Fluid Power Quiz (FLUID-014). **If fluid power is not used on the vehicle, include a statement saying no fluid power is used.**
- If used, hydraulic / pneumatic systems include a pressure release valve and regulator in the system (FLUID-007, FLUID-011), and that any pressurized cylinder, pressure storage device meets the MATE specifications (FLUID-012, FLUID-013).
- **New in 2023!!!** If used, the specifications and details of the hydraulic / pneumatic components used, including pressure ratings of hoses and components.
- Any watertight housing on the vehicle can withstand pressure at 5 meters (MECH-001).
- All propellers are shrouded and have propeller guards (MECH-006).
- The ROV has no sharp edges or elements of the ROV that could cause damage (MECH-006, ELEC-017E).

The following photographs **MUST** be included within the company safety review:

- Anderson Powerpole connector within 30 cm of Littelfuse (show fuse, ruler and connectors)
- Inside of the control box with wires labeled or control system (and controller) for those using a computer or laptop
- Strain relief where the tether connects to the control system
- Strain relief where the tether connects to ROV
- Compressor or pump (if pneumatics/hydraulics are used) including release valve and regulator
- Propeller shrouds (front and back of one propeller)

The company safety review should include an explanation of how each system meets the safety specifications and include photographs of the relevant systems for review by the MATE ROV Competition officials.

### Initial Safety and Documentation Review points

Penalty points will be deducted from the initial safety and documentation review if:

- Companies do NOT submit ALL the required documentation by the given date. See 6.2 KEY DEADLINES.
- The SID does not show a fuse, or the fuse does not use an ANSI, NEMA or IEC symbol.
- Fuse calculations are not shown on the SID.
- The vehicle uses fluid power, but a fluid power diagram is not included.
- A non-ROV device is used but is not shown on any SID.
- Companies not using fluid power, or not attempting a task requiring a non-ROV device, do not state this fact in the company safety review.
- The technical documentation is over 8MB in size.
- Other documents are over 2MB in size.
- The company safety review does not show compliance with all of the specifications.

The initial safety and documentation review rubric can be found [here](#).

### 2.3 Onsite Safety Inspection

Companies must complete their onsite safety inspection before their vehicle enters the water.

Companies advancing to the World Championship must complete their initial on-site safety inspection immediately after checking in. A sign-up form with specific dates and time frames will be circulated in advance of the World Championship. Companies should review this form carefully and select the date and time frame that aligns with their travel plans. Companies that ship their ROV should also consider the expected delivery date and time when making their selection; without a vehicle present, the company will fail their initial safety inspection. Accommodations will be made for companies that experience travel delays beyond their control (i.e., a cancelled flight or flight delay), but these will be the exceptions and not the norm.

Companies are required to check in and undergo their first safety inspection prior to the opening ceremonies.

At the World Championship, companies MUST pass their safety inspection by the end of the first day of the competition. Companies that do not pass their safety inspection by the end of the first day will be disqualified from the underwater product demonstration component.

**NOTE for 2023!!!** A power supply will be available; companies will power up their control system and vehicle during the safety inspection. The inspector(s) will reference the list of violations as he/she conducts the safety inspection of the vehicle using the safety inspection rubric.

What follows is the safety inspection protocol used at the World Championship. For EXPLORER class teams attending a regional, consult [your regional coordinator or visit your regional contest's website](#) for more information about the safety inspection process used at your regional.

## 2.4 Safety inspection protocol

1. Before entering the water for practice or a product demonstration run, the ROV system must go through a safety inspection. Once a company successfully passes inspection, they will turn in their safety inspection sheet to the safety inspector and receive a Blue PASSED Card with their company number on it. Companies must present the Blue PASSED Card to the pool practice/product demonstration coordinator before their vehicles are permitted to enter the water.
2. Competition staff will conduct a safety inspection of the vehicle using the [safety inspection rubric](#).
3. If the safety inspector(s) identify a safety violation, companies will have the opportunity to address it. The pool practice or product demonstration run schedule will NOT change to allow companies more time.
4. If during the second safety review the
  - a. violation has not been properly addressed or
  - b. another violation is revealedcompanies will have ONE additional opportunity to address the issue.
5. If during the third safety inspection a violation still exists, safety inspectors will request that the Chief Judge(s) review the violation. If the Chief Judge(s) confirms the violation, companies will not be permitted to participate in the underwater product demonstration component of the competition. However, companies can still participate in the engineering and communication (technical documentation, engineering presentation, and marketing display) component.
6. Reminder: All companies must present the Blue PASSED Card to the pool practice or product demonstration judge before placing their vehicles in the water. In addition, product demonstration station judges and competition officials can pause or stop a product demonstration run at any time if they feel that there is a potential safety concern.

### **NOTE for 2023!!!**

All items used on the ROV MUST participate in and pass safety inspection. Companies that use a device that did not participate in and pass the safety inspection will be disqualified.

## 2.5 Safety Inspection Points

The safety inspection is worth 30 points. Each time a company fails its safety inspection it loses 10 points. After a company fails its second inspection, it must meet with the chief safety inspector to discuss a plan of action prior to returning to its workstation. THREE STRIKES and a company

- a. Receives 0 points for the safety inspections and
- b. Is disqualified from the underwater product demonstration component

## 3.0 SPECIFICATIONS

The ROV system (or “system”) must meet the following requirements:

### 3.1 Operational

### 3.1.1 Multiple Vehicles

OPER-001: EXPLORER class companies are required to design and build ONE ROV that can complete the necessary product demonstration tasks. “Floating eyeballs” or other vehicles that are not hard connected to the frame of the main vehicle are NOT permitted. Cameras designed to provide a “birds-eye view” are permitted provided that these cameras are hard connected to the frame of the main vehicle. “Hard connection” does not include the wiring between the camera and the ROV.

### 3.1.2 Environmental

OPER-002: The ROV system must be able to function in fresh, chlorinated water with temperatures between 15°C and 30°C. The water should be considered conductive of electrical currents.

OPER-003: The pool will not be covered or purposefully darkened in any way, although the specific product demonstration tasks may require that your ROV operates in low-light.

OPER-004: Depending on the venue, pressurized pool filtration system outlets may cause unexpected currents.

OPER-005: The pool venue at the World Championship has a smooth bottom.

**Note:** EXPLORER companies attending regional competitions should note that regionals may be held in pool venues with different environmental conditions than those listed here. If you are unfamiliar with the regional pool, contact [the regional coordinator or visit your regional contest’s website](#) for additional information.

### 3.1.3 Service Requirement

OPER-006: Companies shall provide a crew of at least 3 but not more than 6 people on the pool deck to operate the ROV System. Companies can send a larger crew complement, but no more than six can be on the deck at any time. More information about this “product demonstration team” is provided in the [COMPETITION RULES](#).

### 3.1.4 Maintenance and Calibration Requirement

OPER-007: All measurement devices shall be calibrated according to manufacturer recommended calibration procedure and performed by company members only. Company mentors or advisors are not permitted to perform calibration procedures. More information about mentor restrictions is provided in the [COMPETITION RULES](#).

OPER-008: System maintenance during field operations shall be conducted by ROV personnel at their workstations. Work of any kind must not be done by company mentors or advisors. All maintenance parts and equipment necessary to meet the operation requirements shall be provided by the company. More information about these regulations is provided in the [COMPETITION RULES](#).

## 3.2 Mechanical/Physical

This section of the document provides specifications for the mechanical properties of the ROV system.

### 3.2.1 Materials

MECH-001: At the World Championship, any electronics housings on the ROV shall be capable of operating to depths of 4 meters.

### 3.2.2 Size and weight

MECH-002: ROVs are limited to a maximum weight, in air, of 35 kg. Vehicles over this weight will not be allowed to compete. Product demonstration tasks will limit the size of the vehicle. Companies must be able to personally transport the vehicle and associated equipment to the product demonstration station and to the engineering presentation room. ROV systems must be capable of being safely hand launched. Additional points will be given to lighter vehicles (see [weight restrictions](#)).

### 3.2.3 Tether Length

#### **NOTE for 2023!!!**

MECH-003E: At the World Championship, ROVs must be capable of operating in a maximum pool depth of 4 meters (12 feet, 2 inches). All underwater product demonstrations will take place within 10 meters from the side of the pool. The product demonstration station will be no more than 3 meters from the side of the pool. Tether length should be calculated accordingly. EXPLORER companies attending regional competitions should note that regionals may be held in pool venues with different maximum depths than those listed here. If you are unfamiliar with the regional pool, contact [your regional coordinator or visit your regional contest's website](#).

### 3.2.4 Vehicle Deployment and Recovery

MECH-004: The ROV system must be launched and recovered manually; no powered winches or portable cranes can be used. Hand-powered lifts and levers may be used to launch and recover the vehicle. The vehicle and any associated equipment must not damage any part of the pool or pool deck.

MECH-005: Any hand-powered lift or levers that are used as a LARS must be detailed in the technical documentation and must be part of the safety inspection procedure. Any LARS equipment that is deemed as unsafe at the safety inspection will not be allowed. Ladders, tripods, or other bracing equipment are not permitted as part of a LARS.

### 3.2.5 Propellers

MECH-006: Propellers must be shrouded and have thruster guards. ROVs that have propellers exposed without thruster guards will not pass the safety inspection and will not be allowed to compete. A shroud must completely encircle the propeller and extend at least 2 mm in front of and behind the propeller. Thruster guards must completely cover any openings on the thruster and should have a mesh size that

meets [IP-20 standards](#) (solid particulate protection level 2). This IP code equates to a mesh size >12.5 mm. To pass safety inspection, the shroud and propeller guard should meet this standard. If your finger can touch the propeller, then it is not properly guarded.

Teams may construct thruster guards, 3D print thruster guards, or may purchase commercially available thruster guards. All motors on the ROV must be protected with shrouds and thruster guards on all sides.

See <https://www.thingiverse.com/thing:1498338> for an example of an acceptable thruster guard.

### 3.3 Electrical

ELEC-001: All power provided to the ROV system through an external connection for any purpose during the competition must be obtained from the MATE competition power supply. This includes dedicated lines for cameras, manipulators, and any other devices. This is a singular point of connection; all power to the ROV must pass through the MATE-provided fuse AND the single in-line fuse as specified in this section.

#### **NOTE for 2023!!!**

Companies **MUST** use one of the following inline fuse(s) that are rated for the voltages used on EXPLORER class ROVs. Circuit breakers will not be allowed on the ROV system.

[30-amp fuse](#)

[25-amp fuse](#)

[20-amp fuse](#)

[Fuse holder](#)

#### **NOTE for 2023!!!**

**COMPANIES ARE REQUIRED TO USE ONE OF THE LITTELFUSES AND THE LITTEL FUSE HOLDER LINKED TO ABOVE.**

These specific components are required. Companies without these components will not pass any of the following:

- video qualification
- initial safety inspection
- onsite safety inspection

If companies cannot purchase these components from the above sources, companies may purchase fuses and fuse holders from the [SeaMATE store](#).

ELEC-002E: The ROV system must be capable of operating off the power provided by a MATE supply with a nominal voltage of 48 VDC. Power supplies will be a fixed output voltage and will not be “turned down” to accommodate other than the specified voltage for the class. All references to 48 VDC in this document are the nominal voltage of 48 VDC.

ELEC-003E: The ROV system must deliver the supply voltage to the ROV as provided and without modification. No conversion of this voltage is allowed prior to it arriving at the ROV system bus. Methods on the surface such as DC/DC converters, voltage drop resistors, and Pulse Width Modulation (PWM) are not allowed to be used between the ROV and the power source. ESCs and H-bridges are not allowed on the surface. Power supplies and conversion devices are not allowed on the surface if they operate the ROV.

MATE strongly urges companies to refrain from sending reduced voltage signals from the ROV back up the tether to power devices on the surface. This is not done by ROVs in industry and therefore discouraged by the MATE ROV Competition.

ELEC-004E: ROV systems may use any voltage desired up to 48 Volts, but any conversion to a lower voltage must be made on board the ROV. Companies will not be permitted to operate an ROV that reduces the voltage on the shore-side/top-side end of the ROV tether.

ELEC-005E: Voltage may not be increased above the nominal 48 volts anywhere in the ROV system.

ELEC-006E: Sonar or other systems that may have DC/DC conversion resulting in voltages above 48V nominal are not permitted.

ELEC-007E: Voltages in excess of the class parameters set forth in this specification are not allowed on the ROV system at any time other than any inductive spikes that are caused by the switching on/off of motors, solenoids and other inductive devices. Companies should design their systems to handle these voltage spikes but will not be penalized for the presence of these in a system. For additional information on this, companies can research back electromotive forces (back EMF), collapsing magnetic motor fields, and transient suppression.

### 3.3.1 Non-ROV Device Power Specifications

#### **NOTE for 2023!!!**

Systems that qualify as a non-ROV device in 2023:

- Vertical profiling float
- Northern Redbelly Dace fry release container

No other devices qualify as non-ROV devices.

ELEC-NRD-001: The vertical profiling float cannot be powered from the surface. If the float is powered, it must use onboard batteries. The fry release container may be powered from the surface or from batteries on board the container. Voltage is limited to 12 VDC maximum; amperage is limited to 6 amps maximum.

At the World Championship, MATE will provide a 12-volt [Powerwerx power supply](#) at each station. The company built non-ROV device fry release container may use this power supply. No other devices may be plugged into this supply. The connection to the MATE provided supply will be red/black [Anderson](#)



[powerpole connectors. https://www.andersonpower.com/shop/powerpoler-15-45-one-row-1x2-assembly-bonded-kr.html](https://www.andersonpower.com/shop/powerpoler-15-45-one-row-1x2-assembly-bonded-kr.html)

[Note: The Powerwerx power supply typically operates at 14.1 volts.](#)

ELEC-NRD-002: The vertical profiling float non-ROV device may not utilize thrusters nor include any cameras. The fry release container may not include cameras or thrusters to move container; it must be deployed by the ROV. The fry release container may include motors to open, close and release the fry.

ELEC-NRD-003: Companies may not power the vertical profiling float non-ROV device from the surface.

ELEC-NRD-004: Onboard power is allowed for non-ROV devices. If onboard batteries are being used, the following specifications must be met:

- Batteries must be primary (non-rechargeable).
- AAA, AA, A, A23, C, D or 9V alkaline batteries are allowed. No other size or chemical composition is allowed. 12-volt, outdoor, rechargeable batteries are **NOT** allowed. High discharge LiPo batteries are **NOT** allowed.
- Batteries are mounted in a manner that they are not loose inside the container.
- A fuse (7.5 amps max) must be installed within 5 cm of the battery positive terminal.
- The enclosure housing must be designed so that it will open if the pressure inside the housing is greater than the outside pressure.
- Any pressure relief plug **MUST** be at least 2.5 cm in diameter. Smaller plugs will not pass safety inspection.
- The enclosure housing must be designed so that it will release pressure if pressure inside the housing is greater than the outside pressure. Under no condition should the housing be built with fasteners to hold the device together if there is no pressure release valve. At least one opening must serve as a pressure release. This can be achieved by:
  - The battery holder must be mounted in a manner that will allow the end cap to freely open if pressure develops inside the housing.
  - Battery containers utilize a pressure release valve AND a Schrader valve. **New in 2023!!!**  
The pressure release valve must be rated no more than 12 psi.

Companies using a pressure release valve for their onboard battery container provide specifications and factory cut sheets of the valve used to the [Competition Technical Manager](#) no later than May 15<sup>th</sup>, 2023 for review by the MATE safety committee.

Examples of acceptable methods for housing batteries include:

- A PVC pipe with wires penetrating one end and the opposite end plugged with a pressure release plug (rubber stopper, etc.). Note: Any pressure release plug **MUST** be at least 2.5 cm in diameter. Smaller plugs will not pass safety inspection.
- Cylinder with batteries mounted inside. One end of the cylinder sealed with caps and O-rings, but no fastening devices holding the end cap on.
- Cylinder with both a properly rated pressure release valve and a Schrader valve.

ELEC-NRD-005: A SID must be submitted for any non-ROV device that uses electrical power.

### 3.3.2 Independent Sensors

Certain product demonstration tasks may require a sensor that is independent of the vehicle. These electrically powered sensors will operate under the following independent sensor rules.

ELEC-IS-001: Independent sensors must be powered from the surface; no onboard batteries are allowed.

ELEC-IS-002: Companies may use USB to connect their sensor to a computer. Companies may also use surface battery packs (limited to 12 volts maximum) or the MATE supply to provide power for their independent sensor.

ELEC-IS-003: The independent sensor may only contain the intended sensor; thrusters, cameras, or other systems MAY NOT be attached.

ELEC-IS-004: Companies that use an independent sensor must provide a 3 amp (or less) fast blow fuse on the positive side of their connection. If companies are using the 48-volt MATE supply to power their sensor, both the ROV and the sensor must run through the single fuse before splitting off to the 3-amp sensor fuse. Companies using USB only to power an independent sensor may utilize the built-in current limiting of USB and do not need to add an additional fuse.

ELEC-IS-005: A SID must be submitted for an independent sensor that uses electrical power.

### 3.3.3 Current

ELEC-008E: ROVs will be limited to 30 amps.

The ROV system must have a fuse that is calculated based upon the maximum current draw of the ROV. This overcurrent protection must be calculated as follows:  $\text{ROV Overcurrent Protection} = \text{ROV Full Load Current} * 150\%$ . The overcurrent protection value may be rounded up to the next standard fuse. The ROV Overcurrent Protection value may exceed 30 amps, but companies are limited to a 30-amp fuse. Companies must use the fuse that is rated for overcurrent protection. Companies that use a fuse larger than their calculated value will not pass safety inspection. Companies may use a fuse smaller than their calculated value without penalty. The fuse must be installed in the positive power supply line within 30 cm of the power supply attachment point. The fuse may be a slow blow type. The SID and other electrical diagrams must show the fuse and include the amperage of the overcurrent protection. In addition, the SID must show the calculations used in determining the overcurrent protection value. SIDs without these calculations shown will have points deducted from the initial safety inspection sheet. Also, SIDs without fuse calculations will not pass safety inspection. The motor current used must be full load current while in water, not while operating in air. Overcurrent calculations using the lower current values will be rejected.

ROV overcurrent protection example 1:

- Eight motors, 2.7 amps each = 21.6 amps
- Two cameras = 0.25 amps
- Two servo motors = 0.8 amps
- One laser = 0.002 amps
- Total Amps: **22.87 amps** X 150% = **33.98 amps**
- ROV uses a **30-amp** fuse

ROV overcurrent protection example 2:

- Four motors, 2.7 amps each = 10.8 amps
- Two cameras = 0.25 amps
- Two servo motors = 0.8 amps
- One laser = 0.02 amps
- Total Amps: **11.87 amps** X 150% = **17.8 amps**
- ROV uses a **20-amp** fuse

All information on overcurrent protection should be included on the SID. Show your work.

The MATE power supply will be protected by a 30-amp fuse; however, the ROV system must also have its own calculated fuse.

ELEC-009E: ROV systems are allowed one replacement fuse during the product demonstration. In the event that the ROV system blows the second fuse during the demonstration, the demonstration will be over, and no additional points will be earned. Companies should have adequate replacement fuses on hand, MATE will not provide replacements. Standard sizes for fuses are 15, 20, 25 and 30 amps. Additional standard fuse sizes are 1, 3, 7.5, and 10 amps.

**Note for 2023!!!**

The required Littelfuse **MUST** be within 30 cm of the connection to the MATE 48-volt power supply. There should be no other components between the SBS50 Anderson Powerpole connection that connects to the MATE 48-volt power supply and the fuse. Companies choosing to use E-stops or control boxes must locate their fuse before any of these components.

No substitute fuses or fuse holders are allowed. Companies **MUST** use on the required fuse holders and fuses.

**3.3.4 Power Connections**

ELEC-010E: Power supply connections will be Anderson Power Connectors. Companies' ROV system power wires must have proper connectors to obtain power. The Anderson Power Connectors must be connected to the ROV power wires securely; use of proper (hydraulic) tooling is required. Hand crimp tools do not have the force necessary to ensure proper and safe connections. MATE will not provide companies with connectors or adapters at the 2023 World Championship.

**NOTE for 2023!!!**

**COMPANIES ARE REQUIRED TO USE THE ANDERSON SBS50 LINKED TO BELOW.**

This specific component is required. Companies without an Anderson SBS50 connector will not pass their video qualification, will not pass their initial safety inspection, nor will they pass their onsite safety inspection.

Housing: Anderson SBS50BLU-BK

DigiKey: [SBS50BLU Anderson Power Products, Inc. | Connectors, Interconnects | DigiKey](#)

Mouser: [SBS50BLU Anderson Power Products | Mouser](#)

Allied Electronics: [SBS50BLU Anderson Power Products | Allied](#)

Additional online sources for the Anderson SBS50BLU connector:

<https://www.andersonpower.com/shop/blue-sbsr50-standard-housings-up-to-110-amps.html>

Pins: The proper pin for your tether conductors

12 or 10 AWG: [Anderson 1339G3-BK](#)

8 AWG: [Anderson 1339G5-BK](#)



<http://leeselectronic.com>

MATE strongly discourages the use of Anderson Powerpole “knock-offs.” These connectors do not meet electrical specifications and have the potential to melt under load.

**NOTE for 2023!!!**

If companies cannot purchase an Anderson SBS50BLU from the above online sources, companies may purchase a kit with these connectors (and the proper Littelfuses/fuse holder) from the [SeaMATE store](#).

ELEC-011E: The power supply may be located up to 1 meter from the station table and may be located on either side of the table. MATE recommends a power cable long enough to reach the power supply up to 3 meters from your control system.

### 3.3.5 Tether Voltages

The signals in the tether must meet the following specifications:

ELEC-012E: Low voltage, low current AC or DC control or sensor signals. Low voltage is defined as a voltage equal to or less than the maximum supply voltage per class specification. Low current is defined as being less than 500mA. Examples include video signals, control signals for electrically powered manipulators, sensor signals, etc.

ELEC-013E: DC main-supply at a nominal voltage of 48VDC as provided by the MATE power supply.

ELEC-014E: Ethernet, USB, or other ANSI or IEC accepted serial protocol signals.

#### **NOTE for 2023!!!**

All cameras, including USB cameras, must be powered by the MATE supply. Powering a USB camera from the MATE supply can be accomplished by using a USB repeater / extender that has a separate power input at the far (ROV) end. The ROV must convert the 48V to 12V or 5V as needed to power the device from the MATE 48-volt supply. This conversion must be done on the ROV. USB cameras plugged directly into laptops are not allowed. Be sure to denote camera power on your SID.

ELEC-015E: NTSC or PAL Video signals

ELEC-016E: Fiber optic cabling of any type may be used.

### 3.3.6 Exposed connections and disposable motors

ELEC-017E: ROVs with electrical connections that are exposed to water and not sealed are not permitted to enter the water. Taping a connection with electrical tape only does not constitute a sealed connection. The process of sealing electrical connections must include methodologies such as, but not limited to, Silicone RTV, hot melt glue, epoxy, self-vulcanizing tape, and enclosure of the connections in a housing.

ELEC-018E: “Disposable motors” are not permitted; these are exposed motors with no waterproofing.

Brushless motors must be properly waterproofed. Companies must show manufacturer documentation showing their brushless motors are waterproof, or companies must properly waterproof their motor and provide documentation showing their methodology. Non-sealed brushless motors will not pass safety inspection.

See the [MATE Technical Bulletin](#) for proper methods to waterproof a brushless motor.

### 3.4 Onboard Electrical Power

ELEC-019E: Onboard electrical power (i.e., power not provided by the tether): Onboard battery power is not allowed on the primary ROV. See [3.3.1 Non-ROV Device Power Specifications](#) regarding onboard power.

NOTE: Water leaking into a closed battery container can result in the generation of hydrogen gas. This gas can build up inside a pressure housing and create an unsafe situation. Any battery housing must be designed to open if the pressure inside the housing is greater than the outside pressure to meet the MATE safety standards. See the non-ROV device onboard battery rules (ELEC- NRD-004) for more information.

### 3.5 Power Shutdown

ELEC-020E: For safety purposes, any ROV system that is disconnected from the surface supply must stop functioning in less than 5 seconds. This applies to electrical, pneumatic, and hydraulic power sources. Any filters, capacitors or accumulators must be sized accordingly to meet this specification.

### 3.6 Fluid Power

Any vehicle using fluid power must provide a fluid power diagram. Fluid power is defined as hydraulic pumps (water) or pneumatic pumps (air) on the vehicle or on the surface.

#### 3.6.1 Hydraulic Power

FLUID-002: Hydraulic fluid: Water or biodegradable food-grade fluid, only.

FLUID-003: If a biodegradable food-grade fluid is used, a Material Safety Data Sheet (MSDS) must be provided at the safety inspection. The MSDS must show the type of fluid used and its compatibility with the Biodegradable Food-Grade specification. Companies using water do not need to provide an MSDS.

FLUID-003: If a biodegradable food-grade fluid is used, a Material Safety Data Sheet (MSDS) must be provided at the safety inspection. The MSDS must show the type of fluid used and its compatibility with the Biodegradable Food-Grade specification. Companies using water do not need to provide an MSDS.

FLUID-004: The following fluids are approved for use in hydraulic systems:

- a. Water
- b. Biodegradable Food-Grade Hydraulic Oil ISO Grade 32/46, SAE Grade 20, McMaster-Carr part# 3499K22

All other bio-degradable food-grade fluids must be approved by the [Competition Technical Manager](#) by May 15, 2023. Companies with regional competitions prior to May 15, 2023, must have their bio-degradable food-grade fluids approved two weeks prior to their regional event.

FLUID-005: Maximum Hydraulic pressure allowed: 10.33 bars (150 psig).

**NOTE for 2023!!!**

FLUID-006: Hydraulic system: All lines, fittings, and hydraulic devices must be rated for a minimum pressure of two (2) times the maximum supply pressure. Hydraulic component specifications must be included in the Company Safety Review.

FLUID-007: Hydraulic pumps must be part of the safety inspection.

1. They must have a pressure relief valve with a maximum setting of 300 psig or less installed before the pressure regulator.
2. The pump must have a regulator in place and set to 150 psig or less.
3. Pumps with any sign of external rust or deterioration will not be accepted.
5. All wiring must be secure.
6. All guards must be in place.
7. Hydraulic pumps may run off of the 15A 115VAC outlet provided for command and control as long as the hydraulic fluid is not used to propel the ROV. The hydraulic fluid is to be used for grippers and actuators only.

**3.6.2 Pneumatic Power**

FLUID-008: Pneumatic fluid: Compressed air or inert gas only

FLUID-009: Maximum pressure allowed: 2.75 bars (40 psig)

**NOTE for 2023!!!**

FLUID-010: Pneumatic system: All lines, fittings, and pneumatic devices must be rated for a minimum pressure of two and a half (2.5) times the maximum supply pressure. For example, if an 83 bar (1200 psig) tank is regulated to 2 bars (30 psig), then all system components must have a minimum rating of 5.17 bars (75 psig). Pneumatic component specifications must be included in the Company Safety Review. **Note: Aquarium tubing is not generally rated for the pressures associated with compressed gas systems and should not be used in a pressurized pneumatic system.**

FLUID-011: Air compressors must be part of the safety inspection.

1. They must have a pressure relief valve installed before the pressure regulator.
2. The compressor must have a regulator in place and set to 40 psig or less.
3. Compressors with any sign of external rust will not be accepted.
4. The tank drain valve must open.
5. If more than 5 ml of water exits upon opening the drain valve, the compressor will not be accepted.
6. All wiring must be secure.
7. All guards must be in place.

8. Air compressors may run off of the 15A 115VAC outlet provided for command and control as long as the air is not used for motor thrust. The air is to be used for buoyancy/ballast, grippers and actuators only.

At the World Championship, the MATE ROV Competition will provide compressed air at each station. Companies using compressed air MUST attach to the provided compressed air; companies may not use their own compressor. See [3.9 MATE Provided Equipment](#) for more information.

### **3.6.3 Pressurized Cylinders**

FLUID-012: Pressurized cylinders may be used, but must remain above the water surface and meet the following specifications:

- a. Approved by US DOT (Department of Transportation) or TC (Transport Canada). For regional competitions taking place outside of the US, check with [your regional coordinator](#) for approval.
- b. Have a current official inspection/test sticker and/or stamp.
- c. Stamped with the maximum allowable pressure.
- d. Contain a pressure relief safety device.
- e. May be filled up to the maximum allowable pressure of the cylinder.
- f. Must be regulated at its output to a maximum of 2.75 bar (40 psig).
- g. Must have an easily accessible shut-off valve that is clearly marked with instructions.
- h. May only be stationed on the surface, not on the ROV.
- i. Must be secured in a safe manner such that they will not fall or roll around. If the judges feel that a cylinder is unsafe, they have the discretion to prevent its use.
- j. SCUBA tanks are permitted. They must meet all the above specifications and have a current visual inspection sticker, or “fill permit” visible.

### **NOTE for 2023!!!**

Electronic housings and other enclosures on the ROV must operate at surface pressure. Companies may not pressurize their electronics housing.

### **3.6.4 Pressure operated devices (PSO)**

MATE will allow the use of soft-walled pressure operated devices in the competition provided they meet the following specifications:

- Device uses a pressure release valve of 12 psi maximum.
- Company provides specifications and factory cut sheets of the valve used and a description of the device to the [Competition Technical Manager](#) no later than May 15<sup>th</sup>, 2023 for review by MATE safety committee.

The intent of the exception to the pressure specifications is to allow the use of bladder type devices and flexible grippers that operate a few psi above ambient and would be destroyed if tested at full MATE



pressure specifications. This exception does not apply to cylinders, pressure vessels or other pressure containment devices. If the device is tested to the 40 psi (pneumatic) or 150 psi (hydraulic) MATE specifications, a pressure release valve is not required.

### **3.6.5 Unpressurized cylinders**

FLUID-013: Companies may fill containers on the ROV with air provided those containers never exceed ambient pressure. Any such container should have at least one ¼-inch (6.35 mm) hole drilled into the bottom of the container to allow excess air to spill out.

### **3.6.6 Pressure Storage Devices (Pressure Accumulators)**

FLUID-014: Pressure storage devices are allowed on the ROV if they do not exceed 1.25L in total storage and do not store pressure higher than the allowed pressure for air or hydraulics. It is recognized that a company may not be able to purchase a pressure accumulator that has the proper rating and fits in the space needed. In that case, the company must show that their designed accumulator is capable of withstanding the specified pressures without rupture.

### **3.6.7 Chemical Creation of Gases**

The chemical creation of gases is not allowed.

### **3.6.8 Fluid Power Quiz**

FLUID-015: EXPLORER class companies planning to use hydraulics and/or pneumatics (i.e., fluid power) are required to take and pass an online quiz with a score of 100%. Companies ONLY using manual pumps and unpressurized containers are not required to take the Fluid Power Quiz but must still submit documentation regarding their fluid power system.

NOTE: The quiz was developed by MATE ROV Competition technical support staff and competition judges and is designed to ensure that companies understand basic information on these topics and can apply that knowledge to safe practices. The intention is not to add yet another “requirement,” but rather to provide a safe and successful learning experience and competition environment.

The quiz should be completed by the STUDENT company members. Each member of the company does NOT have to take the quiz; students can work together and make it a group effort. **ONLY ONE TEST PER COMPANY.** The company’s instructor or mentor can provide guidance and advice, but the questions should be answered by the students participating on the company. The quiz will be scored, and the results provided instantaneously. A score of 100% is considered a passing grade. Companies can take the quiz as many as 5 times to achieve this score.

**The quiz must be completed with a passing grade by April 26<sup>th</sup>, 2023. NO EXCEPTIONS OR EXTENSIONS!** Companies with regional competition prior to April 26<sup>th</sup> due date should plan to take the fluid power quiz at least 2 weeks prior to their competition. If registration for your regional competition opens after the fluid power closing date, you must still take the quiz before April 26<sup>th</sup>. Companies failing

to complete this quiz within the given time frame will NOT be permitted to use fluid power during their competition event. **NO EXCEPTIONS OR EXTENSIONS!** See [6.2 KEY DEADLINES](#).

To purchase and take the fluid power quiz, click [here](#).

The following are sources of information on hydraulics and pneumatics. This is not intended to be an exhaustive list, but rather a starting point to encourage companies to seek out additional information and resources.

- [Underwater Robotics: Science, Design, and Fabrication \(Revised Edition\)](#), published by the MATE Center and MATE Inspiration for Innovation
- <https://www.nfpa.com/home/About-NFPA/What-is-Fluid-Power.htm>
- <https://www.quincycompressor.com/tips-for-working-safely-with-compressed-air/>
- Parker Hannifin Corporation – <http://www.parker.com/> (look for technical literature links)

### 3.7 Control Systems

ELEC-021E: EXPLORER class ROVs are expected to utilize computer- or electronic-based control methodologies and H-Bridge or BLDC controllers for the thrusters. Systems using surface switch box controllers are not permitted.

ELEC-022E: Surface control stations must be built in a neat and workmanship like manner. Loose components and unsecured wires will not pass safety inspection.

ELEC-023E: Surface control stations by nature may combine 120VAC and 48VDC wiring. The surface control stations must be wired in a manner such that the 120VAC wiring is physically separated from the DC wiring, the 120VAC wiring is clearly identified from the DC and control voltages, and every conductor is insulated in a manner that no conductor is exposed. Identification can be through signage and/or wire color schemes. All 120VAC wiring colors must use ANSI, NEMA or IEC standard wiring colors appropriate to each voltage. There must be a sign inside the surface control station indicating which wiring standard is being utilized. Companies that do not have adequate separation of AC wires and components and DC wires and components will NOT pass safety inspection. It is recommended that separation be designed into the control system to keep power systems separate. Wiring should be clear, neat and easy to follow by inspectors. Wiring “Rat’s nests” or “spaghetti wiring” will not pass safety inspection.

ELEC-024E: Companies must use proper strain relief and abrasion protection where wires and the tether enter the vehicle. The ROV should be capable of being lifted by the tether without damaging the tether connection to the ROV. Tape, glue, zip ties, and other quick methods of strain relief are not acceptable. The intent is to see the wires pass through a connector specifically designed to provide strain relief.

Companies must use proper strain relief at the surface where wires and the tether enter the control system. Pulling on the tether should not strain the wires entering the control system or computer/laptop.

Examples of some acceptable strain reliefs for the ROV side include:

[Hubbell Strain Relief 1](#)

[Hubbell Strain Relief 2](#)

[Strain relief grip](#)

[Kellums strain relief cord grip](#)

ELEC-025E: Any connectors utilized in the surface control station and elsewhere in the ROV system must be properly type rated for their application. AC rated connectors must not be used for DC. The connectors must also be rated at or above the voltage and current used in their application.

## 3.8 Command, Control, & Communications (C3)

### 3.8.1 Power Provided

CCC-001: Surface power: MATE will provide one GFI-protected outlet with a nominal 115 Volts AC (60 Hertz) and 15 amps maximum. This outlet is intended to provide power for pumps and other surface support equipment (e.g. video monitors & control boxes). This AC power source CANNOT be used to directly or indirectly power the vehicle.

CCC-002: If hydraulic or pneumatic power is used for vehicle thrust, the power for the pump must come from the MATE supplied DC power supply.

CCC-003: In addition to electric pumps, hydraulic, and pneumatic systems can be powered by manual pumps (e.g. bicycle tire pump) or supplied from a pre-pressurized cylinder. Companies that are only using manual pumps must still comply with all hydraulic and pneumatic specifications, including the creation of a fluid power SID.

### 3.8.2 Displays

CCC-004E: Companies are not limited to the number of display screens used for video feeds or ROV status information. Display devices may be made up of any combination of TVs, monitors, laptops, and/or computer displays.

CCC-005E: These display devices may be powered by the MATE provided GFI-protected 115-Volt AC (60-cycle) and 15-amp AC power source described in CCC-001, Surface power.

CCC-006E: A company's C3 station may include devices like video recorders. All C3 devices must be able to run on the single AC power outlet provided or on its own internal battery power. Any device plugged into this AC power outlet can only provide C3 functions and cannot provide power to the ROV.

CCC-007E: A company's C3 station should have all items stable or secured to the station. Large monitors not secured to and stable in the product demonstration station are not permitted. Monitors and other C3 devices with glass faceplates are not permitted.

### 3.9 MATE Provided Equipment

MATE will **NOT** provide video monitors at the product demonstration stations.

In 2023, the MATE ROV Competition will supply compressed air at each station during the World Championship. Companies may connect to this compressed air via a [standard ¼-inch NPT male fitting](#). For companies attending an EXPLORER regional, contact your [regional coordinator or visit your regional contest's website](#) as to whether compressed air will be provided at your regional competition.

#### 3.9.1 Companies Sharing Equipment

Companies may share the following equipment during the competition event: monitors and joysticks/controllers.

Companies may NOT share the following equipment during the competition event: control systems and payload tools (e.g. grippers, manipulators).

For companies attending an EXPLORER regional, contact [your regional coordinator or visit your regional contest's website](#) to determine if equipment can be shared at your regional event.

Companies that plan to share equipment during the World Championship event must notify the [Competition Technical Manager](#) at least 4 weeks prior to the event so that this can be considered when creating the schedule. MATE will do its best to accommodate companies sharing equipment.

### 3.10 Laser Safety Rules

LASR-001: **Companies must forward the specifications of their laser to the [Competition Technical Manager](#) by May 15<sup>th</sup>, 2023. Specifications MUST include a link to the laser being used. The link should include a photo of the laser and the laser specifications.** A notification will be sent to the company when the laser is approved. Companies must also bring a copy of their laser specifications to their safety checks. If the laser is being used at a regional event or pool practice, notification will also be sent to the regional competition coordinator.

LASR-002: All lasers must operate in the visible range at either the 630-680 nm (red) or near the 532 nm (green) wavelength. All lasers must fall into the Class I, Class II, or Class IIIa category. Red lasers must operate at 5mW or less. Green lasers must operate at 1 mW or less.

LASR-003: Companies should include detailed specifications of their laser in their technical documentation as well as have that information ready and available during their safety inspection and engineering presentations.

LASR-004: Lasers must have an on/off switch. This switch must be on the surface controller.

LASR-005: All lasers must be powered by the MATE surface power supply. Batteries, including batteries for powering lasers, are not permitted on the vehicle.

LASR-006: Companies using lasers cannot increase the voltage or the current to increase the power of their lasers. Lasers must use the voltage and current set in their specifications.

LASR-007: When out of the water, the laser should have a shield or enclosed beam stop attachment within 30 cm of the laser. This means that the laser beam should not travel more than 30 cm before reaching the shield. This is a requirement at all times when the laser is out of the water. **New in 2023!!!** The beam stop must be attached to the ROV at all times. Companies may not remove the beam stop by hand when the ROV enters the pool. The beam stop should be designed so it floats or moves out the way of the beam when the ROV is in the water. The shield must be painted with FLAT BLACK paint.

LASR-008: At no time should the laser be focused or deviate from a collimated beam.

LASR-009: When testing the laser at a workstation, companies must display a sign telling others that a laser is being operated.

LASR-010: Operators working with the laser while the ROV is out of the water should wear appropriate laser safety glasses at all times. This requirement is for all laser types. Search online to find laser safety glasses appropriate for the wavelength being used.

**Companies must forward the specifications of their laser safety glasses to the [Competition Technical Manager](#) by May 15<sup>th</sup>, 2023. Specifications MUST include a link to the laser safety glasses being used. The link should include a photo of the laser glasses and the laser glasses specifications.** A notification will be sent to the company when the laser safety glasses are approved. Companies must also bring a copy of their laser safety glasses specifications to their safety checks. If more than one brand of glasses are used, a copy of each specification sheet should be provided.

The following lasers are acceptable to use in the MATE ROV Competition, although companies may choose to use alternate lasers. NOTE: **ALL COMPANIES MUST STILL FORWARD SPECIFICATIONS TO THE COMPETITION TECHNICAL MANAGER, EVEN IF ONE OF THE FOLLOWING ACCEPTABLE LASERS IS USED.**

- [Amazon.com: HiLetgo 10pcs 5V 650nm 5mW Red Dot Laser Head Red Laser Diode Laser Tube with Leads Head Outer Diameter 6mm : Industrial & Scientific](#)
- [DaFuRui 3Pack \(Dot Laser\)650nm Focusable Focus Adjustable Lens Laser Red Dot Diode Module 3-5V with Driver Plastic Lens - - Amazon.com](#)

## PART 4: COMPETITION RULES



Teamwork/  
Collaboration



Content  
Knowledge



Safety



Vehicle Design,  
Buoyancy, Propulsion

### 4.1 GENERAL

- All members of the company and their supporters must follow the safety regulations of the ROV competition, pool facility, and event venue.
- All company members and their supporters are expected to conduct themselves in a professional and responsible manner during the competition. Disrespectful behavior towards the judges, officials, pool staff, audience, or other companies will lead to penalty points or disqualification.
- Sabotaging, stealing, or pilfering equipment of other companies will lead to disqualification. Companies found cheating will also be disqualified.
- The MATE ROV competition is, at its core, designed to be an educational and inspirational event for **STUDENTS**. It is designed to challenge them to apply the physics, math, electronics, and engineering skills they are learning in the classroom to solving practical problems from the marine workplace. (See the [MATE Competition Philosophy](#).)

It is expected that all “adults” (non-students; e.g. teachers, mentors, parents) involved in the competition limit their input to educational and inspirational roles. Actual construction of the ROV (particularly in the complex electrical and software areas) must be completed by the students. Adults should teach and advise students about design, electronics, software, and construction, but not complete the work for the students. Throughout the process adults are encouraged to focus on benefits to the students from the process and not simply winning. If it becomes apparent that adults exercised more than an advisory role, judges reserve the right to deduct points or, in extreme cases, disqualify companies from the competition.

ALL work done on the vehicle must be conducted by company members. This includes any work done at home, at school, or during the MATE ROV competition (World Championship and regional). Teachers, mentors, parents, and non-competing students are not permitted to work on the ROVs. They may provide advisory input, but they may not work on the ROV directly. This includes writing or editing software code. All mechanical, electrical, and software modifications and/or repairs to the ROV must be completed by students.

With learning at its core, the MATE competition encourages students to utilize and build upon their skill sets to find creative solutions to designing and building their ROV. Students gain valuable skills and knowledge when creating a component from “scratch,” which is apparent to judges as they

review the technical documentation and engineering presentation. However, as they move through the process of analyzing their designs and identifying building materials, students may decide to either build a component from “scratch” or purchase it from a commercial vendor.\*\*\* So, while original solutions are encouraged, the use of commercial components is acceptable, provided 1) that the components adhere to the design and building as well as safety specifications for the particular competition class and 2) more importantly, that the students can provide a reasonable, logical explanation for buying versus building.

The competition scoring rubrics are designed to reflect this; points are awarded based on students’ abilities to explain and justify how all of the components and systems work together as an integrated ROV, regardless if they purchased them, pulled them from public libraries, or made them themselves.

\*\*\*Note “commercial vendor” includes the [SeaMATE store](#) and other competition programs that sell educational robotics kits. SeaMATE kits were created to remove barriers to participation for teachers and schools unable to easily 1) find parts and materials and 2) set up accounts with multiple vendors. The kits are part of a larger educational package that includes curriculum materials, videos, and other resources to support and enhance learning. And learning is what students who use SeaMATE (or other) kits will be expected to demonstrate during and through the [ENGINEERING & COMMUNICATION](#) components.

It should be noted that purchasing and competing with complete, assembled, commercial ROVs is not permitted.

## 4.2 PROCEDURAL

- Companies must compete during their assigned time slots. Your company is **NOT** permitted to switch time slots with another company. Failure to show for your scheduled product demonstration or for your company’s engineering presentation will result in “no score” for that particular competition category. **No exceptions.** Assigned time slots will be sent out in advance so that any scheduling concerns can be addressed prior to the event.

\*Regional contests may refer to the product demonstration station as the control “station” or “shack.”

- Companies must complete their weight measurements before each product demonstration run. The weight measurements are included as part of the product demonstration score. Companies should be at the weigh in area at least 20 minutes before their scheduled product demonstration run.
- While there is no limit to the number of students who can compete as part of a company, **the product demonstration team (aka demo team) is limited to six students.** The demo team is

defined as the team of students who operate the vehicle and its associated equipment during the product demonstration. Only six students will be allowed to enter the product demonstration station, launch, pilot, and perform the tasks. Instructors, mentors, and/or non-student members cannot participate as part of the demo team. **Companies may alternate students on the demo team for the two product demonstration attempts.** (All members of the company should participate in the engineering and communication components; see [ENGINEERING & COMMUNICATION](#) for more information.)

- Only the demo team members and judges are allowed at the product demonstration station during the product demonstration, which includes the set-up and demobilization periods. Other members of the company, instructors, mentors, audience members, and observers (press or special invited guests) must remain outside the product demonstration station or in designated viewing areas.
- Instructors, mentors, parents, and “fans” are **NOT** permitted at the safety inspection stations or repair tables. Two warnings will be issued before individuals not heeding this rule will be asked to leave the venue.
- In addition, instructors, mentors, parents, and fans are **NOT** permitted to work on the ROV. Individuals who are seen working on the ROV who are not student company members will be issued a warning. Two warnings will be issued before individuals not heeding this rule will be asked to leave the venue. If companies choose to take their ROVs off the competition grounds for maintenance and repair, they are expected to observe this rule in the interests of the spirit of the competition.
- To help enforce this, teachers, mentors, parents, and non-competing students MAY have limited access to the workstation areas. Contact the [MATE ROV Competition officials](#) for more information.
- Video devices may be used to record the underwater activities for entertainment and learning purposes **only**. Video will not be used as an instant replay to review judges’ decisions or to challenge product demonstration timing.
- Product demonstration stations will be roped off and marked. Product demonstration stations will contain 2-3 chairs and one 6-foot table long table for companies to use. This table will be within 3 meters of the pool edge. Product demonstration stations will be set up to prevent the pilot(s) from looking at the ROV in or under the water except through the ROV cameras.
- Companies will compete in one product demonstration that will consist of three tasks. Companies will get TWO attempts at the one product demonstration. The higher of the two scores will be added to the engineering and communication score to determine the total, overall score for the competition.



- The product demonstration time consists of a 5-minute set-up period, a 15-minute performance period, and a 5-minute demobilization period. If the demo team and all of their equipment are not out of the product demonstration station at the end of the 5-minute demobilization period, the company will be **penalized 1 point for each additional minute**.

**Note:** Regional competitions *may not* offer two attempts at the product demonstration. Regional competitions may allow more or less time to complete the product demonstration. EXPLORER class companies participating in a regional competition should contact their [regional coordinator or visit their regional contest's website](#) for more information.

- Manipulating the tether to free it from underwater obstacles is permitted. Pulling on the tether to speed up the recovery of items or to return your vehicle more quickly to the surface is not permitted and will result in penalty points. Judges will issue one warning if tether pulling occurs. Each future infraction will result in 5 points deducted from the final product demonstration score.
- SCUBA diver assistance will be available at the World Championship. If help is required, the company CEO or pilot must ask a station judge and divers for assistance. Each diver assist will incur a 5-point penalty. The product demonstration clock will not stop if a company is receiving diver assistance.

Diver assistance may not be available at your regional competition. EXPLORER class companies participating in a regional competition should contact their [regional coordinator or visit their regional contest's website](#) to determine if diver assistance will be available at your regional competition.

- Pilots can only leave the product demonstration station and move poolside to repair, adjust, or alter a vehicle if the ROV is surfaced and at the side of the pool.
- Companies are not permitted to leave debris in the pool. Any debris must be recovered by the ROV before time has expired or the company will be penalized. Debris is defined as pieces of the ROVs, weights, floats, or other items created by the company. Task props are also not considered debris. The product demonstration notes section may cover special items that can be left in the pool after time has expired.
- No demo team member shall enter the water to complete an object recovery. Only arms and hands are allowed into the pool to retrieve an object or to retrieve the vehicle. Companies will be disqualified or penalized depending on the severity of the infraction.
- Communication between demo team members at the pool edge and demo team members piloting the vehicle will be limited. Only tether management issues (e.g. how much tether is out, how much is remaining on the pool deck) can be discussed. Those team members at the pool edge cannot give any directional or product demonstration task information to the pilot. Judges will issue one

warning regarding illegal communication. Each future infraction will result in **5** points deducted from the final product demonstration score.

- Communication using cell phones, text messaging, and online social media tools such as Zoom, Skype, Facebook, Twitter, instant messaging, etc. is NOT permitted during the product demonstration, either between the demo team members at poolside or between any demo team member and anyone outside of the product demonstration station. The ROV and/or the ROV control system is not allowed to broadcast video or other information to anyone outside of the product demonstration area. No exceptions. Companies found broadcasting any data to those outside of the product demonstration area will be disqualified.
- **Product demonstration judges and other competition officials will only communicate with students.** Judges and officials will NOT communicate with mentors, parents, or other non-student members regarding product demonstration information, challenges, or other issues except during pre- and post-competition briefing sessions.

Companies that wish to issue a challenge during the product demonstration run should immediately communicate this challenge to the product demonstration judges. The judges will discuss and attempt to resolve the issue. If a decision cannot be made, the product demonstration judges will consult with the head judges and competition technical manager to resolve the issue.

- ***NOTE for 2023!!!*** Once a chief judge rules on a challenge, that ruling is final. NO EXCEPTIONS, including appeals to other competition officials. Penalty points may be given if companies continue to pursue the challenge beyond the chief judge's final ruling.

#### **4.3 DESIGN & SAFETY CONSIDERATIONS**

- The competition coordinators and host venues stress the importance of safety practices and procedures to all companies. The score sheets and rubrics will reflect the MATE ROV Competition's efforts to encourage and reward companies that demonstrate exceptional safety practices and procedures.
- **ALL ROVS MUST PASS A SAFETY INSPECTION CONDUCTED BY COMPETITION OFFICIALS PRIOR TO ENTERING THE POOL.** These inspections will be conducted topside to ensure that ROV systems meet the design and building specifications and do not pose a risk to the integrity of the event venue. See [VEHICLE DESIGN & BUILDING SPECIFICATIONS](#) for additional information.
- Radio transmitters that operate on a separate battery are permitted. No batteries are permitted to be in or on the water. No exceptions.

Companies should be aware of all the implications of these wireless devices. There is no assurance that an adjacent company’s wireless controller will not interfere with your control systems. Adjacent wireless controllers with a battery that has a higher charge than the nearby controller have demonstrated the ability to “hijack” the nearby control signals. In addition, all wireless controllers are susceptible to external sources of electronic interference. Your system may work fine in your home environment, but not in the industrial environment of the competition. MATE will not stop the clock to resolve wireless control issues. Companies deciding to utilize wireless controllers do so at their own risk.

- Keep an eye out for tripping hazards in the product demonstration station and at your company’s workstation. Make sure power cords are not laying in pools of water on the deck.
- During your product demonstration, be sure to secure any equipment so that it does not fall off the product demonstration station table, damage the deck, or cause injury.
- Loose fitting clothing, jewelry, and long hair could all become safety issues. Consider securing long shirts or baggy pants, removing jewelry, and tying back long hair when working on or operating your ROV.
- ROVs may be constructed out of materials of your company’s choice, provided they meet the design and building specifications and safety regulations. Warning labels should be posted on potentially hazardous components of your ROV system.
- Close toed shoes are required on the pool deck. Safety glasses are required when working on the vehicle.
- Personal flotation devices (PFDs) will not be required at the World Championship. No personal flotation devices will be provided by MATE or the host venue. Regional events may require PFDs. EXPLORER class companies participating in a regional competition should contact their [regional coordinator or visit their regional contest’s website](#) to determine if PFDs will be necessary.

## PART 5: ENGINEERING & COMMUNICATION



**NOTE for 2023!!!**

MATE has created an ROV Competition [Marketing Kit](#) that includes logos and guidelines for their use.

The ability to communicate information about your vehicle and the design and building process is equally as important as how well your vehicle performs. Strong communication skills are an essential part of good business practices and one of the most in-demand skills in the constantly evolving, ever-changing workplace.

To emphasize this point, the competition requires the following five engineering and communication components:

- Company spec sheet
- Technical (written) Documentation (Examples of spec sheets and technical documentation from previous competitions can be found in the [MATE ROV Competition Archives](#).)
- Engineering (oral) Presentation (Examples of engineering presentations can be found on [MATE's Vimeo channel](#).)
- Marketing Display
- Corporate Responsibility (OPTIONAL)

**NOTE: EXPLORER class regional contests may not require all of the Engineering & Communication components.** Contact [your regional coordinator or visit your regional contest's website](#) for more information.

See the [TIPS FOR EFFECTIVE WRITTEN AND ORAL COMMUNICATION](#) for additional information.

**NOTE for 2023!!!**

Your company should refer directly to the scoring rubrics posted under [Scoring](#) for details on what is required for your technical documentation, engineering presentation, and marketing display. The judges will use the rubrics to evaluate and score these engineering and communication components.

## 5.1 COMPANY SPEC SHEET

The purpose of the company spec sheet is to provide the judges with a “snapshot” of your company. It includes basic information about your company and vehicle.

Company spec sheets will be reviewed by MATE competition coordinators. Companies will receive up to 20 points for submitting a spec sheet that is **one page** in length, follows the file size and naming specifications, and contains **all** of the following information:

### COMPANY SPECS

- **Company and school, club, or community organization name**

- **Home state and/or country**
- **Distance required to travel to the World Championship**
- **History of MATE ROV competition participation.** Be sure to specify if your company and/or the members of your company are “new” or “returning.”
- **Company photo and caption indicating members’ names and roles (e.g. CEO, CFO, Design Engineer, Pilot, etc.).** This photo should include all of the members of your company.
- **Range of grade/college levels represented by the members of your company**

#### **ROV SPECS**

- **ROV name** if applicable
- **Total cost.** You must include the approximate cost of any donated items.
- **Size and weight measurements**
- **Total student-hours to design and build.** This should include the number of hours that each and every member of the company worked on the vehicle.
- **Safety features**
- **Special features**
- **Photo of the vehicle**

**REMINDER!!!** If all of the above information is included, the specifications for length, size, and naming conventions are followed carefully, and the document is submitted on time, this is an “easy” 20 points! You can find the company spec sheet scoring rubric posted [here](#).

## **5.2 TECHNICAL DOCUMENTATION**

The purpose of the technical documentation is to challenge you to effectively and efficiently communicate information using clear and concise text along with graphics, illustrations, and data that add to and complement (and not distract from) the information. Your company must organize and present the information in a way that is logical and complete. The document should focus on the technical and safety aspects of your ROV/ROV systems, the design rationale behind your engineering decisions, and a critical analysis of testing and troubleshooting done on the vehicle. You should consider this document a reference for both judges and future team members (part of the company’s institutional knowledge).

Your company’s technical documentation will be reviewed and evaluated by a panel of working professionals – individuals who represent science, exploration, government, and industry. (Don’t assume that these same individuals will evaluate your company’s engineering presentation!)

Each judge on the panel will award a score (100 points max). Judges’ scores and comments will be returned to you shortly after the event.

**NOTE: The judges will not review and rescore revised versions of your technical documentation during the competition.**

Use the technical documentation scoring rubric posted [here](#) as the guideline for the required components for the technical documentation. This rubric will be posted by March 1, 2023. In the meantime, companies may refer to the previous year's rubrics for a general idea of the categories and points.

### 5.3 ENGINEERING PRESENTATION

The purpose of the engineering presentation is to challenge you to effectively and efficiently communicate information with words and “props” (i.e., the ROV). Your company must organize and present the information in a way that is logical and covers the development and testing of your ROVs and the formation and development of your team. The presentation should be delivered as a “technical brief,” with references to the technical documentation for additional details (companies should present judges with ONE copy of their document at the start of the presentation). The presentation is THE opportunity your company has to 1) communicate directly and in person your critical thinking, creativity, and engineering reasoning (including build vs. buy) and 2) demonstrate your individual and collaborative contributions to the creation of the vehicle.

During the competition, your company will have 15 minutes to deliver your presentation to a panel of working professionals – individuals who represent science, exploration, government, and industry. (Don't assume that these same individuals will evaluate your company's technical documentation!) After the presentation, the judges will take 10-15 minutes to ask the members of your company questions about your ROV. The judges will evaluate both your presentation and responses to their questions. Each judge on the panel will award a score (100 points max). Judges' scores and comments will be returned to you shortly after the event.

**All student members of your company must be prepared to participate in this presentation and the question and answer (Q&A) period.** You are required to have your ROV with you. For larger companies, the main presentation may be done by a subset of the overall company. During the Q&A, all members of the company should be prepared to answer. However, if one student is better suited to answer a specific question, the others may defer the question to that student to answer. For example, if a judge calls on the pilot to answer a question about the tether, the pilot can respond by informing the judge that the tether manager was the lead on that system and allow the tether manager to answer without penalty or loss of points.

**NOTE:** The engineering presentation is designed to be a face-to-face interaction where students and representatives from industry become engaged in conversation. MATE will not provide audio visual aids, such as slide projectors, computer projection screens, white boards, etc.; however, you are welcome to distribute handouts to help judges better understand the information that you are presenting. Electronic forms of presentation (e.g. PowerPoint or Keynote slides) **are NOT permitted.**

**Instructors, mentors, family members, friends, and members of other companies are permitted to**

**attend.** However, we ask that those in attendance be respectful and courteous throughout the presentation and follow-up question and answer period. Be mindful that this presentation may be a stressful time for the students. If the room becomes crowded or the spectators become distracting, it is up to the judges' discretion to request that some or all spectators leave the presentation. **While they are permitted to attend, instructors and mentors are not allowed to participate.**

**Use the engineering presentation scoring rubric posted [here](#) as the guideline for the required components for the engineering presentation. This rubric will be posted by March 1, 2023. In the meantime, companies may refer to the previous year's rubrics for a general idea of the categories and points.** Judges may ask questions regarding any of these topics not covered in the presentation as well as other questions about the vehicle, the mission theme, or the company.

### **Preparing for your engineering presentation and Q&A**

- Make sure that every member of your company has a good, general working knowledge of your vehicle, even though they may have specialized in one specific aspect of its design and construction.
- Make sure that all the members of your company are familiar with your technical documentation. Ask every member to read it over to catch any errors or omissions. This exercise will help to familiarize everyone with all aspects of the project.
- Generally, you will have more to say about your ROV than can be presented in 15 minutes. That is why it is critical to organize your material and practice communicating it. However, avoid coming across as having memorized your presentation verbatim. Judges want to see that you are prepared and understand the information, not that you can simply regurgitate a rehearsed speech from memory. Ask your instructors or mentors to give you feedback.

### **Other important items**

- If during the engineering presentation it becomes apparent that instructors, mentors, and other adults associated with your company exercised more than an advisory role, judges reserve the right to deduct points or, in extreme cases, disqualify companies.

## **5.4 MARKETING DISPLAY**

The purpose of the marketing display is to challenge you to present technical information in a way that appeals to and is understood by a non-technical audience. It is the promotional piece – you must not only present information about your ROV and your company, but you must also use graphics and design to publicize and “sell” (convince viewers of their value and excellence) your products and people.

During the competition, your company's display will be evaluated and scored by a completely different group of working professionals – individuals who will represent science, business, government, industry, and education/outreach.

While some judges will have a technical background, others will have a communications, marketing, or public relations background. In addition, there will be visitors to the competition who may not completely understand what an ROV is or how it is used. Think of these visitors as potential future clients who may authorize funding for your work but have a limited understanding of the technology (i.e., you need to explain your technology, the tasks at hand, and “sell” them on YOUR products and services). Design your display to communicate to this type of audience.

Each judge will award a score (50 points max). Judges’ scores and comments will be returned to you shortly after the event.

\*\*\*\*\*

**WORLD CHAMPIONSHIP COMPETITION ONLY!**

**NOTE:** The MATE ROV Competition will NOT supply display boards.

**You must provide your own display board. The space that the text and photographs/graphics occupy CANNOT exceed 36” tall by 48” wide. For example, company names CANNOT be mounted above the display board. NO EXCEPTIONS!**

At the World Championship, either easels or tables will be provided for the displays. EXPLORER class companies participating in a regional competition should contact their [regional coordinator or visit their regional contest’s website](#) to see if tables (easels or other) will be provided at your regional event. Companies should create their marketing displays so that they can be exhibited on either a table or an easel.

MATE will continue to provide scissors, tape, glue sticks, adhesives, and other means of attaching display items to the presentation board, although you are also welcome to bring your own.

\*\*\*\*\*

**Use the marketing display scoring rubric posted [here](#) as the guideline for the required components for the marketing display. This rubric will be posted by March 1, 2023. In the meantime, companies may refer to the previous year’s rubrics for a general idea of the categories and points.**

**Creating an effective marketing display:**

- Address the theme and make real-world connections.
- Reflect your company’s personality and mindset.
- Make key points and be concise.
- Keep the general public in mind.
- Make sure to label any and all figures, graphs, diagrams, and photographs and credit the source.
- Maximize the use of the 36” by 48” display space.
- Make sure that it is both informational and aesthetically pleasing.



**Note:** “Accessories” such as video footage, PowerPoint slide presentations running on laptop computers, video projections, etc. are permitted but should be used with discretion. Remember that the judges will have a limited amount of time to evaluate your marketing display and may find excessive use of audio or video presentations distracting.

However, if you do make a video of your ROV building or competition experience, please submit information about it to the [MATE ROV Competition officials](#) so that it can be shared via MATE’s YouTube and Vimeo channels.

## 5.5 CORPORATE RESPONSIBILITY

The MATE ROV Competition uses underwater robotics to inspire and encourage students’ interest in STEM (science, technology, engineering, and math) education and careers. Recognizing that the students who participate in MATE competitions are powerful ambassadors for the program as well as effective leaders in raising awareness of important issues and bringing about positive change, companies have the opportunity to earn up to 20 points for “corporate responsibility.”

Corporate responsibility includes, but is not limited to, the following:

- **Mentoring** consists of, for example, providing guidance to other students in your area who are designing and building an ROV for the competition or a science or other project.
- **Engaging the community** includes demonstrating your ROV and sharing information about your company at festivities and other community-wide events. Presenting to a Rotary Club or your school districts board of directors are other examples.
- **Media outreach** consists of:
  - o Developing a list local media contacts
  - o Writing a press release about your participation in the MATE ROV competition
  - o Distributing it to your media contacts
  - o Following up with your media contacts to see if they’re interested in your company and its ROV
  - o Compiling a summary of results

Here are some [general guidelines](#) for working with the media. They are specific to the World Championship but can be easily modified for regional events.

- **Raising awareness of environmental, social, and governance (ESG) issues. Just look at this year’s theme and product demonstration tasks for ideas – from installing marine renewable energy platforms to reduce carbon emissions to healing the environment and monitoring the health of the oceans.**
- Corporate responsibility efforts will be reviewed by competition coordinators and awarded 0 to 20 bonus points, depending on the number and scope of the outreach and awareness activity(s), i.e., the number of other students or members of the community engaged, the number of mentoring sessions, etc.

Make sure to include the following information in your write-up:

- Type of activity (e.g. mentoring, exhibiting at a community event, raising awareness)
- Locations, dates, and the amount of time spent on the activity
- Number of students or community members (if a large event, this can be an approximate) involved
- Description of your actions, outcomes, and other information that helps to demonstrate the quality of your time and efforts
- For media outreach, please submit a copy of your press release, a copy of your media contacts list, and a summary of news articles, TV or radio coverage, etc. that your company received. Include copies of articles and URLs, and list any television or radio coverage. Be sure to include name of outlet, date, and a summary of the coverage.

### ***Update for 2023!!!***

The MATE ROV Competition is not offering points for VR Assets.

### **TIPS FOR EFFECTIVE WRITTEN AND ORAL COMMUNICATION**

Communicating ideas about how to solve a problem and evaluating those ideas against competing alternatives is a critical skill for anyone entering the workplace. It is a skill that is directly linked to decision making about whether or not to hire (or fund) us and our ability to influence the work that we do.

The key to a successful technical documentation and engineering presentation is the way that critical thinking and engineering reasoning are communicated. You can think of the process as technical “storytelling.”

Technical storytelling includes the use of text, images, schematics, and data to effectively communicate the “story” of how your company brainstormed and evaluated ideas to come up with your solution (e.g. ROV, payload tools, and operational strategies) to the problem at hand (product demonstration tasks). It also involves organizing content to efficiently present your work and justify why you did what you did.

However, you should choose details with care. Each detail should help to answer the question "why is what you did the best solution for your company and for this competition?" Describe why a component in the system is critical and how you chose it. Include specifications or dimensions only if they help to explain the “why” and “how” you made choices. Keep in mind that a mechanical drawing with dimensions can replace a lot of text and in many cases do a better job telling details of the story than text.

That said, if something is hard to describe clearly and completely with two to three sentences, consider whether using an image may help. A good technical document balances text and images to provide lots of information concisely, which for a detailed understanding while being quick and easy to read. Remember that your reader is new to your design and needs to understand both what your design is

and the process you used to get there. Present text and images in a logical order that helps readers follow your development process and results.

Maintaining a project notebook is a good business practice that will help to capture ideas and document your company's progress – including your research, designs, trade studies, experiments, data, vehicle specifications, testing, expenditures, and donations. The notebook is also a place to keep track of your company member's contributions (time, support, etc.).

Along with your notebook, here are some items to consider as you prepare to tell your story:

- What was your company's "work breakdown structure" (tasks, time, and people)?
- What were the greatest constraints (schedule, budget, equipment, labor, logistics, etc.) on your design process?
- How did the product demonstration tasks and rules influence your design and decisions?
- What systematic process, such as a tradeoff matrix, did you use to evaluate competing design solutions?
- What were the most important design decisions you made and why?
- How did you arrive at your final power budget? What concessions, if any, did you have to make and why?
- How do you calibrate your sensors?
- If your vehicle uses software, where does the code execute? Describe the flow and format of the data.
- Did you have a noteworthy troubleshooting experience? Any problem or procedure that takes more than 20 minutes to figure out is worth understanding and writing down.

## PART 6: SUBMISSION GUIDELINES AND KEY DEADLINES



### 6.1 Documentation

Companies advancing to the World Championship are required to submit technical documentation, a company spec sheet, a SID, a fluid power diagram (if fluid power is used), a non-ROV device design document, a non-ROV device SID, and a company safety review. In addition, companies may submit a JSA and documents supporting their corporate responsibility efforts.

**Regional competitions may not require all documentation.** EXPLORER class companies participating in a regional competition should contact their [regional coordinator or visit their regional contest's website](#) to determine what documentation must be submitted for your regional and the date it is due.

**NOTE for 2023!!!**

The links provided in this section are for companies advancing to and submitting documentation for the World Championship. Regional coordinators will provide their own link for regional submissions.

**Regional submissions sent to the MATE ROV Competition management team or to World Championship officials are NOT guaranteed to be forwarded to the regional coordinator.**

DOC-006: All required documentation sent to the MATE ROV Competition officials MUST be in searchable PDF format (see <https://fd4686477cb19f983f54-68abf00cbc1a2cc111562c013cb867db.ssl.cf1.rackcdn.com/SearchablePDFs.pdf> for information about creating searchable PDFs.

DOC-007: The technical documentation may be up to 8 MB in size, the other documents are restricted to a maximum file size of 2MB.

DOC-008: All documents should use the following naming convention: School or organization name\_company name\_DOCUMENT TYPE\_2023.pdf, where DOCUMENT TYPE is technical documentation, spec sheet, SID [type – electrical or fluid], non-ROV device design, company safety review, or JSA.

See [Documentation Submissions Guidelines](#) for information on submitting your documentation. **Submit all of your final documents** in one email. Revised documents submitted at a later date will not be accepted. The MATE competition will use the date-stamp on your form to determine your initial submission.

Before submitting documentation, check to verify that all the files have been attached. Once submitted, companies should verify that all the proper documents were uploaded. If there was an error while submitting your documents, contact the [MATE ROV Competition](#) and upload **ALL** documents again.

DOC-009: For the World Championship, due date for the required documentation is 11:59 PM, Hawaii Time Zone, on May 24, 2023.

DOC-010: Companies will lose points on their initial safety and documentation review if documents:

- 1) Are submitted late
- 2) Exceed the size limit
- 3) Use improper naming conventions
- 4) Are not submitted on ONE form

*6.1.1 Video Demonstration Requirements*

DOC-011: See [Documentation Submissions Guidelines](#) for information on submitting your demonstration videos.

DOC-012: For the World Championship, due date for the video demonstration submissions is 11:59 PM, Hawaii Time Zone, on May 15, 2023.

DOC-013: Videos must be submitted as links to a YouTube or Vimeo post. Companies may submit the specification and product demonstration as two separate videos. Note that the product demonstration portion must be a complete, uncut video.

The video MUST indicate the school/organization and the team name, as well as the competition year, 2023.

MATE competition organizers will review the videos and respond by May 19<sup>th</sup>. Video submissions will NOT be accepted after May 15<sup>th</sup> – NO EXCEPTIONS. Video conferences will not be scheduled after May 15<sup>th</sup>. If the video does not clearly demonstrate that the company's vehicle meets the specifications and accomplishes the tasks, the company is not eligible to participate in the World Championship. No extensions past the due date will be given for any reason.

**MATE strongly encourages companies to submit their videos or arrange for a video conference with a MATE official well before May 15<sup>th</sup>.** That way, if an issue is found, companies will have the opportunity to address the issue and submit an updated video, or schedule another video conference, before the May 15<sup>th</sup> deadline. **Note that it may take MATE up to 5 working days to evaluate a video submission or respond to a request to schedule a video conference.**

NOTE: By submitting your video demonstration links, you are giving the MATE ROV Competition permission to publish these video links on its web site.

#### *6.1.2 Corporate Responsibility Documentation*

DOC-014: See [Documentation Submissions Guidelines](#) for information on submitting your corporate responsibility documentation.

DOC-015: The following naming convention should be used for corporate responsibility documentation: School or organization name\_company name\_Corporate Responsibility ##\_2023, where ## is the number of the document uploaded. You can upload a variety of file types (pdfs, jpegs, etc.) and multiple files, but the size of each file should not exceed 2MB. Number each file to distinguish between them.

Before submitting documentation, companies should verify that all the files have been attached. If companies experience an error when submitting documents, contact the MATE ROV Competition and upload **ALL** documents again. Revised documents submitted at a later date will not be accepted. The MATE competition will use the date-stamp on your form to determine your initial submission.

DOC-016: For the World Championship, due date for the corporate responsibility documentation is 11:59 PM, Hawaii Time Zone, on May 24, 2023.

NOTE: By submitting your documentation, you are giving the MATE ROV Competition permission to publish these documents on its web site.

## 6.2 KEY DEADLINES

Below is an updated summary of key dates and deadlines for the 2023 MATE ROV competition season. Note that EXPLORER regional competitions will have their own set of key dates and deadlines. For companies attending regionals, contact [your regional coordinator or visit your regional contest's website](#) for more information.

- December 1, 2022: Registration opens (note that registration for the World Championship and individual regional competitions will open as locations and dates are secured).
- April 26, 2023: Last day to register for the fluid power quiz.
- May 15, 2023: Last day to submit laser specifications, hydraulic fluid information, and pressure release valve specifications. Companies with regional competitions earlier than May 15 should plan to submit specifications early to allow at least 1 week for approval.
- May 15, 2023: EXPLORER class video demonstration submission deadline.
- May 24, 2023:
  - Technical documentation
  - Company spec sheet
  - SIDs (including electrical, fluid, Non-ROV Device)
  - Non-ROV device design document
  - Company safety review
  - Job site safety analysis (optional)
  - Corporate responsibility documentation (optional)