

2024 COMPETITION MANUAL

RANGER CLASS

RELEASE: DECEMBER 2023



MTS 
marine technology society



2024 MATE ROV COMPETITION:

OBSERVING OUR OCEANS: UNDERSTANDING OUR WORLD AND CREATING OUR FUTURE

RANGER CLASS COMPETITION MANUAL

For general competition information, including a description of the different competition classes and eligibility requirements, visit [Compete](#).

CONTENTS

<i>OBSERVING OUR OCEANS: UNDERSTANDING OUR WORLD AND CREATING OUR FUTURE</i>	1
OVERVIEW	3
THINK OF YOURSELVES AS ENTREPRENEURS	4
RANGER CLASS – REGIONAL PARTICIPATION/DEMONSTRATION	5
PART 1: PRODUCT DEMONSTRATION	6
OVERVIEW	6
SCORING OVERVIEW	6
TIME	7
CONTEXT & NEED	8
REQUEST FOR PROPOSALS (RFP)	9
WEIGHT RESTRICTIONS	21
PRODUCT DEMONSTRATION	22
TASK 1: <i>OOI Coastal Pioneer Array</i>	22
TASK 2: <i>SMART Cables for Ocean Observing</i>	24
TASK 3: <i>From the Red Sea to Tennessee</i>	26
TASK 4: <i>MATE Floats!</i>	36
PRODUCT DEMONSTRATION RESPONSIBILITIES	42
PART 2: PRODUCT DEMONSTRATION PROP BUILDING INSTRUCTIONS & PHOTOS	43
PART 3: VEHICLE DESIGN & BUILDING SPECIFICATIONS	43
1.0 GENERAL	43
2.0 SAFETY	43
2.1 Job Site Safety Analysis	44
2.2 Safety Pre-Inspection	46
2.3 Onsite Safety Inspection	49
2.4 Safety inspection protocol	50
2.5 Safety Inspection Points	51
3.0 SPECIFICATIONS	51
3.1 Operational	51

3.2 Mechanical/Physical	52
3.3 Electrical	53
3.4 Onboard Electrical Power	60
3.5 Power Shutdown	60
3.6 Fluid Power	60
3.7 Control Systems	63
3.8 Command, Control, & Communications (C3)	64
3.9 MATE Provided Equipment	65
3.10 Laser Safety Rules	66
PART 4: COMPETITION RULES	67
4.1 GENERAL	67
4.2 PROCEDURAL	69
4.3 DESIGN & SAFETY CONSIDERATIONS	72
PART 5: ENGINEERING & COMMUNICATION	73
5.1 COMPANY SPEC SHEET	74
5.2 TECHNICAL DOCUMENTATION	75
5.3 ENGINEERING PRESENTATION	75
5.4 MARKETING DISPLAY	77
5.5 CORPORATE RESPONSIBILITY	78
TIPS FOR EFFECTIVE WRITTEN AND ORAL COMMUNICATION	79
PART 6: SUBMISSION GUIDELINES AND KEY DEADLINES	81
6.1 Documentation	81
6.2 KEY DEADLINES	84



This work is licensed under a [Creative Commons Attribution-NonCommercial-NoDerivatives 4.0 International License](https://creativecommons.org/licenses/by-nc-nd/4.0/). Under this license you may download this document. Please give credit to the MATE ROV Competition. You may not use these materials for commercial purposes without written permission from the MATE ROV Competition. Please click on the Creative Commons link above for license details.
materovcompetition.org

Edits are highlighted in yellow.

January 5, 2024.

Pg. 74. Included links to marketing displays.

Pg. 82. Documents submitted may be published on the MATE ROV Competition website.

January 8, 2024.

Pg. 52. Removed formatting error.

January 10, 2024.

Pg 53. MECH-006: This IP code equates to a mesh size <12.5 mm.

January 16, 2024.

Pg. 18, 22, 23-24: Task 1. Due to safety concerns and the potential to damage the pool, the bullet point for manually returning the multi-function node to the surface, side of the pool has been removed. Points for that task have been added into the previous bullet point for connecting the recovery line to the bale.

OVERVIEW

From Technical to Teamwork, Problem-Solving, Creativity, and Critical Thinking: MATE Develops Skills for Success in the Workforce

As you prepare to develop and deploy technologies to monitor ocean conditions and understand ecosystems, make sure to find a moment to reflect on the skills that you are developing to allow you to tackle these tasks. These are the skills that you will take with you along your educational journey and pathway into the workplace.

They also happen to be the skills that are in high demand by employers around the globe. Machine learning, data analytics, AI, video marketing, critical thinking, creativity, collaboration, time management, and leadership – articles published by [LinkedIn](#) and [Forbes Magazine](#) highlight these technical and employability (aka “soft”) skills as the most “in-demand for the next 10 years” and, likely, beyond.

A number of these skills could be described as “entrepreneurial,” part of a skill set that also includes the ability to understand the breadth of business operations (from using data analytics to make informed financial decisions to researching and critiquing potential design solutions and producing content for media outreach); acknowledge your strengths (and weaknesses!); work as an integral part of a team; and apply technical knowledge and skills in new and creative ways. By developing a business acumen, a mindset for innovation and collaboration, and an understanding of how to take environmental, social, and governance (ESG) factors into consideration when making business decisions, you will be well prepared for the global workplace and ready to tackle today’s (and tomorrow’s!) challenges.

As you read through this manual you will see the following icons:*



These icons correspond to the employability (orange) and ROV-specific (green) knowledge and skills that

you gain as you build your ROV and prepare for the competition and which of the various competition requirements – from the Product Demonstration to Engineering and Communication – help to develop each of these skills.

** These icons are from [Evaluate-Compete](#), which is designed to help give you a competitive edge in preparing for the competition and the workforce! High school and college teams are invited to participate in the project's pilot testing phase. Visit [Evaluate-Compete](#) for more information."*

THINK OF YOURSELVES AS ENTREPRENEURS

In this way, the MATE ROV Competition not only encourages you to reflect on the skills that you develop, but, for more than a decade, has also challenged you to think of yourself as an entrepreneur, embrace the skills that being one requires, and transform and organize your team into a start-up company. Use the following questions as a guide to assist you with this process:

- What is your company name?
- Who are its leaders, including the:
 - CEO (chief executive officer – the leader)
 - CFO (chief financial officer who oversees the budget and spending)
- Who manages Government and Regulatory Affairs (i.e. who's in charge of reviewing the competition rules and making sure that they are understood and followed by everyone)?
- Who is responsible for research and development (aka R&D)?
- Who is responsible for system(s) engineering? Design integration? Testing? Operations?
- Who is responsible for fund-raising, marketing, and media outreach?
- Who is the company's ESG research and engagement analyst?
- What other positions might you need? (Depending on your personnel resources, more than one person may fill more than one role.)
- What products and services do you provide?
- Beyond MATE, who are your potential clients?

"10 CHALLENGES - 10 YEARS - ONE OCEAN"

In short, the MATE ROV Competition's philosophy is about student learning. It is about the knowledge and skills gained through participating in the competition and how that knowledge and those skills prepare you for your future career in the ocean STEM workforce – and [beyond](#).

As you contemplate your future education and career plans, the challenge presented to you today is how to apply your knowledge and skills to addressing the competition mission tasks so that we can effectively consider and respond to the question "how do we move from the ocean we have to the ocean we want?"

Again this year the MATE ROV Competition is highlighting the [United Nations Decade of Ocean Science for Sustainable Development](#) and aligning its mission tasks with the "10 Challenges for Collective Impact". This 2024 MATE ROV Competition also continues to inspire ESG principles in order to do "good

for good” for our ocean planet and global community. Again this MATE ROV Competition season the “client” is us – our global community of learners, inspired by the ocean, innovating and collaborating to address societal challenges. You are presented with a request for proposals (RFP), the specifics of which are included below.

RANGER CLASS – REGIONAL PARTICIPATION/DEMONSTRATION

All companies participating in the RANGER class are required to take part in a regional event.

Companies that win their regional event are eligible to advance to compete in the RANGER class at the MATE World Championship. The total number of RANGER winners that advance to the World Championship depends on the total number of individual SCHOOLS or ORGANIZATIONS (not teams) that participate in the RANGER class at the regional (not only register but participate on contest day).

- Regionals with fewer than 5 individual schools/organizations can advance at least one team to the World Championship provided that the team submits and passes a [video demonstration](#).
- Regionals with 5 – 10 individual schools/organizations send the top ONE team to the World Championship.
- Regionals with 11 – 20 individual schools/organizations can send the top TWO teams to the World Championship.
- Regionals with 21+ individual schools/organizations can send the top THREE teams to the World Championship.
- The regional hosting the World Championships can send one additional team above their allotment to the World Championship competition.

Companies will be assigned to the regional that is geographically closest to their location. If companies are located equidistant from two or more regionals, the MATE competition coordinator and the coordinators of those regionals will discuss with the company which regional is most appropriate.

RANGER class companies that are prohibitively far from a regional event should contact [MATE competition coordinators](#) for information about conducting a [video demonstration](#).

NO RANGER class companies will be permitted to participate in the World Championship without either 1) advancing from their regional event or 2) submitting a video demonstration that is then approved by MATE competition officials.

PART 1: PRODUCT DEMONSTRATION



OVERVIEW

RANGER class companies will take part in ONE product demonstration that consists of four distinct tasks:

TASK #1: Ocean Observing Initiative: Coastal Pioneer Array

TASK #2: SMART Cables for Ocean Observing

TASK #3: From the Red Sea to Tennessee

TASK #4: MATE Floats!

NOTE: Regional competitions may not include all 4 tasks of the product demonstration; regional competitions may also give companies more than one attempt at the product demonstration. [Contact your regional coordinator or visit your regional contest's website](#) to determine what will take place at your regional competition. Regardless, the product demonstration score will be added to your [ENGINEERING & COMMUNICATION](#) and [SAFETY](#) scores to determine your total, overall score for the competition.

SCORING OVERVIEW

The competition consists of product demonstrations, engineering and communication, and safety with the following scoring breakdown:

- **Product demonstrations**
 - 350 points (max), plus a time bonus
 - Weight restrictions
 - 10 points (max)
 - Product demonstration organizational effectiveness
 - 10 points (max)
- **Engineering & Communication**
 - Technical documentation
 - 100 points (max)
 - Engineering presentations
 - 100 points (max)
 - Marketing displays
 - 50 points (max)
 - Company Spec Sheet
 - 20 points (max)
 - Corporate Responsibility
 - 20 points (max)

- **Safety**
 - Initial Safety and Documentation Review
 - 20 points (max)
 - Safety Inspection
 - 30 points (max)
 - Job Safety Analysis (JSAs)
 - 10 points (max)

TOTAL POINTS = 720

NOTE: Regional contests may not require all of the Engineering & Communications components or offer the opportunity to earn points for Corporate Responsibility. [Contact your regional coordinator or visit your regional contest's website](#) for more information.

TIME

Each product demonstration includes:

- 5 minutes to set up at the product demonstration station
- 15 minutes to attempt the tasks
- 5 minutes to break down and exit the product demonstration station

Your company will have 5 minutes to set up your system, 15 minutes to complete the tasks, and 5 minutes to demobilize your equipment and exit the product demonstration station. During the 5-minute set-up, you may reassemble your vehicle after the weigh-in and place it in the water for testing and/or trimming purposes. The 15-minute demonstration period will begin after the full 5 minutes of set up time expires, regardless of whether the company is ready to start the product demonstration. It may begin sooner if your CEO notifies the product demonstration station judges that your company is ready to begin.

At any time during the demonstration, you may pilot your ROV to the surface and remove the vehicle from the water for such things as buoyancy adjustments, payload changes, and troubleshooting, but the 15-minute product demonstration clock will only stop if a judge determines it is necessary for reasons beyond your control. Otherwise, the clock will only stop after all of the tasks are successfully completed, the ROV has been piloted into the “resident ROV” docking station under its own power. Your ROV is not required to return to the surface between tasks.

Your 5-minute demobilization will begin as soon as the 15-minute demonstration time ends, regardless of where your ROV is located (i.e., still at depth, in the docking station, on the surface, etc.).

Regional competitions may alter the set-up, product demonstration time, or demobilization time. [Contact your regional coordinator or visit your regional contest's website](#) to verify the timing of your product demonstrations.

TIME BONUS

Companies will receive a time bonus for each product demonstration if you:

- 1) successfully complete all the tasks,
- 2) return your ROV to the surface under its own power so that it touches the side of the pool, and
- 3) physically touch your vehicle before the demonstration time ends.

Companies will receive 1 point for every minute and 0.01 point for every second under 15 minutes remaining.

CONTEXT & NEED

It's official – and we are still celebrating!

On July 1, 2023, MATE Inspiration for Innovation, along with the MATE ROV Competition, the SeaMATE Store, MATE professional development workshops, and instructional resources that support student learning, became part of the [Marine Technology Society \(MTS\)](#).

For MATE, it is a “homecoming;” while the MATE ROV Competition has evolved and expanded over the years, with its “alumni” embarking on careers in the ocean enterprise and other sectors, the mission to inspire and develop the next generation of ocean professionals remains at its core.

For MTS, it extends its reach to a much younger audience, one that is primed to connect with this international community of ocean scientists, engineers, practitioners, policy-makers, and educators – first as students then as early career ocean professionals then as society leaders.

We are also still celebrating the [United Nations Decade of Ocean Science for Sustainable Development](#). Via the MATE ROV Competition mission scenarios and tasks, we continue to highlight the Decade, embrace and inspire [ESG](#), and challenge our global community of learners to come together to inspire, innovate, and create solutions to the problems that impact us all.

By now you know that the United Nations (UN) proclaimed a [Decade of Ocean Science for Sustainable Development \(2021-2030\)](#) to support efforts to reverse the cycle of decline in ocean health and to gather the global community behind a common goal: creating improved conditions for sustainable use and development of our world ocean. More recently, the UN Decade of Ocean Science for Sustainable Development laid out “[10 Challenges for Collective Impact](#).” The four mission tasks of the 2024 MATE ROV Competition align with those challenges and, like the U.N., ask us to consider “how do we move from the ocean we have to the ocean we want?”

From expanding the Global Ocean Observing System to protecting and restoring ecosystems and biodiversity and unlocking ocean-based solutions to climate change, the 2024 competition mission tasks focus on SOLUTIONS that include ocean observing assets for data collection, reimagining the utility of telecommunications cables, administering probiotics for diseased coral, identifying healthy habitats for lake sturgeon, and deploying GO-BGC floats to monitor ocean health. Again this year we embark on the 2024 season with optimism that together we can inspire, innovate, and create technology solutions to

mitigate the impacts of climate change and pave the way to a sustainable future. And with ocean technologies and scientific data to support us, we are also optimistic that we can influence mindsets and guide communities to embrace and adapt practices for the good of us all.

If you have competed in the MATE ROV Competition over the last 3 years, it will come as no surprise that once again this MATE ROV Competition season the “client” is us – our global community of learners, inspired by the ocean, innovating and collaborating to address societal challenges. We acknowledge and embrace the UN’s “10 Challenges - 10 Years - One Ocean” and task our MATE competition community to design and build a remotely operated vehicle and the necessary sensors, tooling, and complementary technologies to monitor the health of the aquatic habitats of our Blue Planet, so that we can proactively and confidently answer the question “how do we move from the ocean we have to the ocean we want?”

REQUEST FOR PROPOSALS (RFP)

1. General

- a. *OOI: Coastal Pioneer Array – Relocating ocean observing assets to “answer pressing science questions and gather data”*

Ocean Decade Challenges for collective impact:

#7 Expand the Global Ocean Observing System

The Ocean Observatories Initiative (OOI) is an ocean observing network that operates and maintains instruments that collect and deliver data to better understand the ocean, its complexity, and how it is changing as a result of natural and anthropogenic processes. Funded by the U.S. National Science Foundation (NSF), OOI connects researchers, educators, and the general public to a wide range of ocean instrumentation through its cyberinfrastructure, all without the need to go to sea. The data collected by the more than 900 OOI instruments are freely available around the clock in near real-time.

OOI has three major observatory elements that are linked together by instruments, infrastructure, and an information management system: global ocean arrays, regional cabled arrays, and coastal arrays. The data collected and delivered by these arrays are helping to inform and advance the understanding of ocean processes as well as contribute to “products” that support commercial industries – and people’s livelihoods. For example, data collected by OOI’s Coastal Endurance Array and other ocean observing instrumentation contributed to improved forecasting of seasonal hypoxia (low oxygen) conditions in the Pacific Northwest, which enabled the Dungeness crab fishery to make informed management decisions, including the placement and harvesting of crab pots.

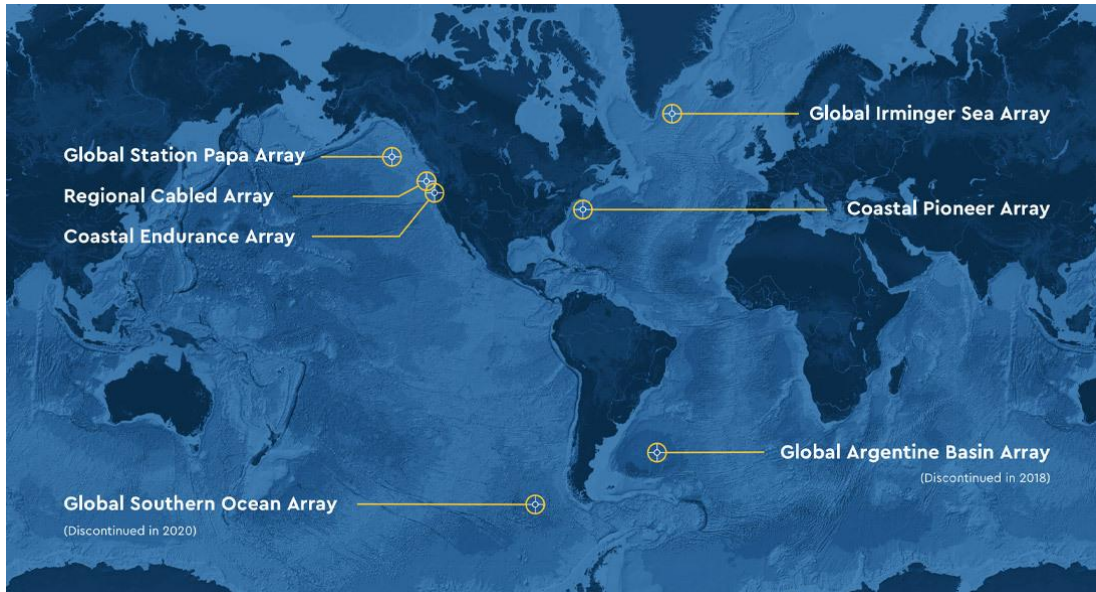

A map showing 7 of the 11 OOI arrays ([The Arrays - Ocean Observatories Initiative](#)).

One OOI element, the Coastal Pioneer Array, was designed as a re-locatable array suitable for moderate to high winds, waves, and currents on the continental shelf and upper slope. The Coastal Pioneer Array was installed in 2016 off the coast of New England, about 75 nautical miles south of Martha’s Vineyard. The array consisted of moored platforms, such as surface buoys, profiler moorings, and benthic multi-function nodes, and autonomous vehicles. It was maintained by the Woods Hole Oceanographic Institution (WHOI).

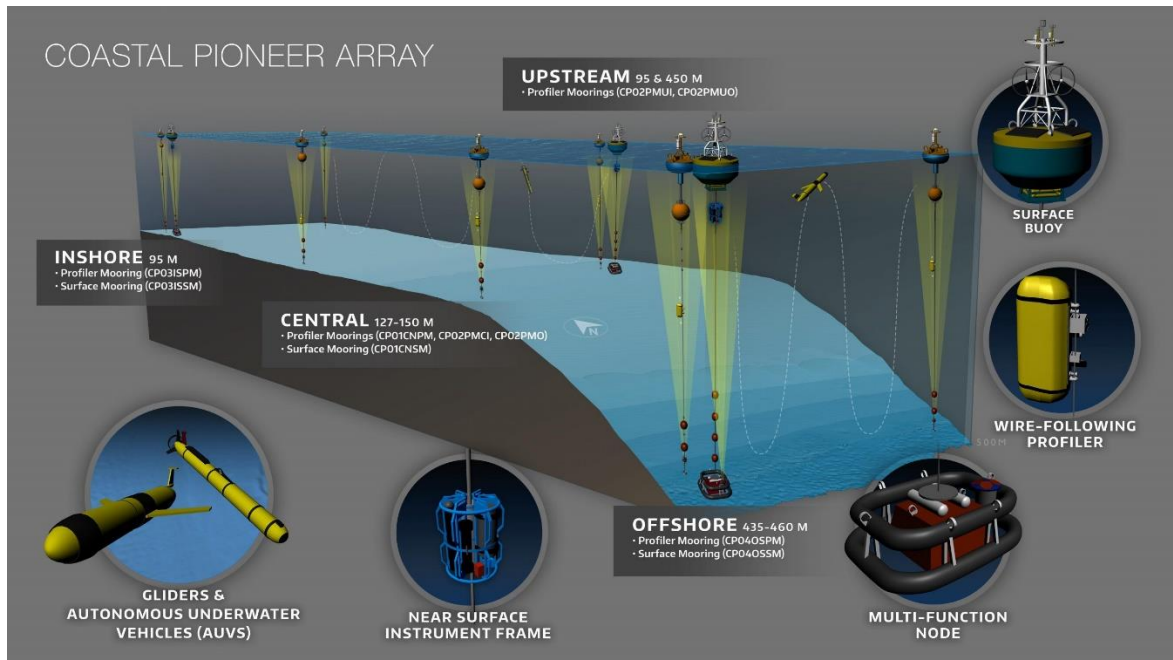

The instrumentation assets of the Coastal Pioneer Array ([Coastal Pioneer New England Shelf Array - Ocean Observatories Initiative](#)).

After discussions with OOI partners and the broader scientific community, NSF proposed the Southern Mid-Atlantic Bight between Cape Hatteras and Norfolk Canyon off the coast of North Carolina as the next location for the Coastal Pioneer Array. Led by WHOI, planning for the relocation of the array started in June 2021.

Fast forward to December 2023 – the instrumentation assets and infrastructure of the Coastal Pioneer Array have been recovered and are currently out of the water awaiting the necessary permitting so that they can be installed along the Mid-Atlantic Bight. The target date for installation is April 2024.

Operations to remove the array’s assets from the water included triggering acoustic releases to free recovery floats. Once on the surface, these floats and the lines connecting the floats to the multi-function nodes (and their anchor weights) are “hooked” by a surface support ship and the assets are brought on board.

b. SMART Cables for Ocean Observing: “Undersea cables connect the planet – what if they could help save it?”

#7: Expand the Global Ocean Observing System

Science Monitoring And Reliable Telecommunications (SMART) Cables is an initiative to equip transoceanic telecommunications cables with sensors that collect data on ocean health and monitor seismic activity. SMART Cables are just that – “smart” – in that they leverage the transoceanic cable power and communications infrastructure to collect and transmit temperature, pressure, and seismic acceleration data – all of which are critical environmental parameters of the deep ocean that are currently under-sampled. This data will not only provide valuable insights into the state of the ocean, it will also provide a significant societal benefit by improving earthquake and tsunami early warning systems.

It is estimated that there are currently 1.4 million kilometers (or just under 1 million miles) of submarine cables traversing the ocean floor. These cables have a lifespan of approximately 25 years, at which time they need to be replaced. The SMART concept is to integrate SMART Cable systems into replacement cables – or into new ones as the cable network expands, fueled by billions of dollars of investments and driven by the world’s hunger for connectivity, especially in developing nations.

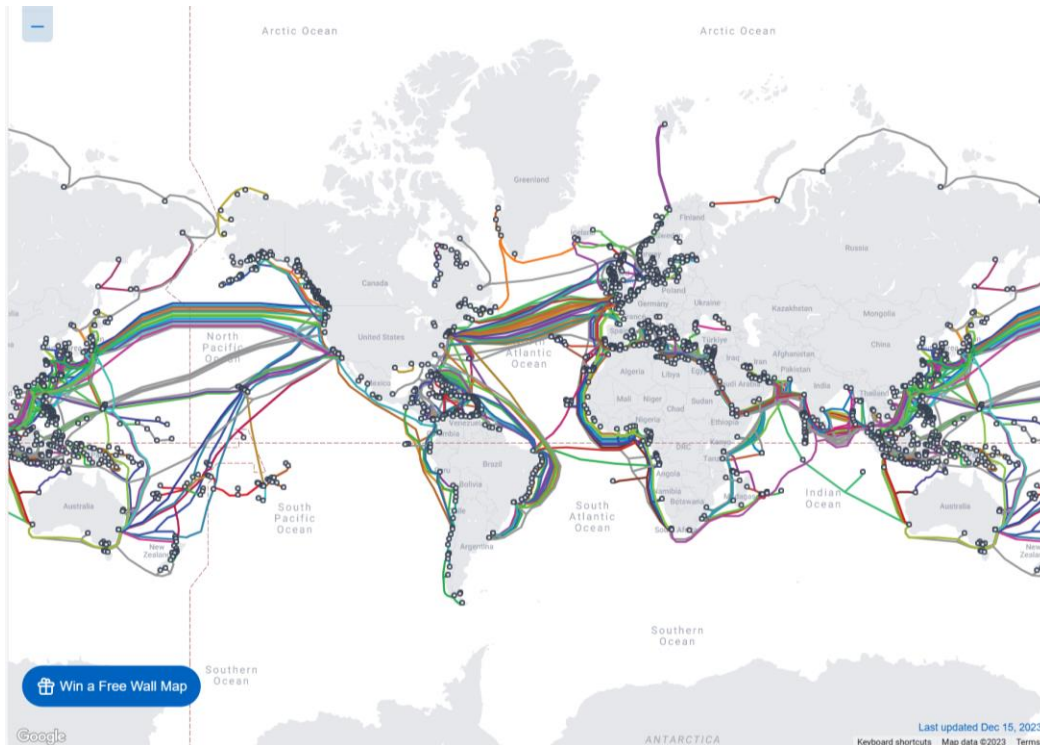

A snapshot of the current map of submarine telecommunication cables ([Submarine Cable Map](#)).

At the core of the “smart” innovation is the SMART Repeater, which houses the sensors that measure temperature, pressure, and seismic acceleration and includes a pass-through for the telecommunications cable. The telecommunications cable consists of copper wire or a copper sheath, which the sensors tap into for power, and fiber optics for data transmission, which allow the sensor data to be shared and communicated in real-time.

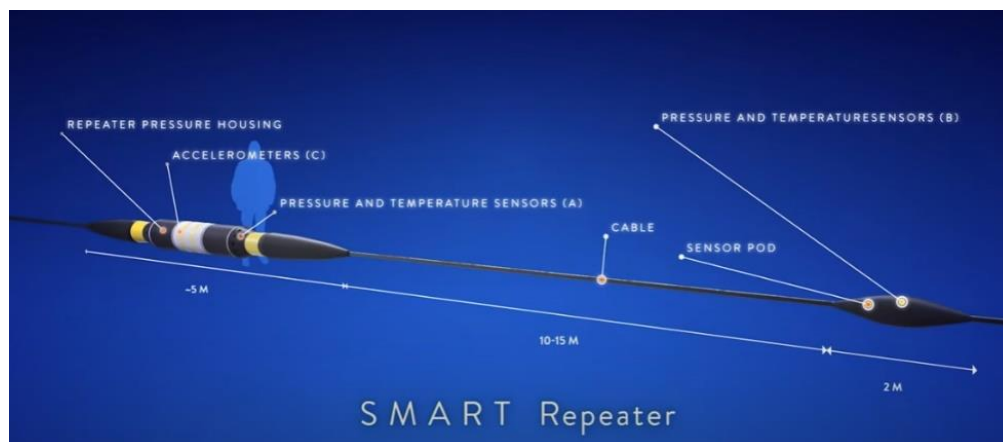

A SMART Cable Repeater ([SMART Cables for Ocean Observing](#)).

It has taken over 10 years from the initial concept to the point where a SMART Cable system is finally in development. The CAM (Continent - Azores - Madeira) cable ring off the coast of Portugal will be the first telecommunications/SMART Cable system. The existing CAM ring is up for replacement, so the plan is to take advantage of the replacement effort and incorporate a SMART Cable system, which will

involve laying 3,700 kilometers of cable that includes 50 SMART repeaters (one every 74 km or so). The cable will travel from Lisbon to the Azores to Madeira and back to Lisbon, crossing seamounts, ridges, and other benthic features, along its route.

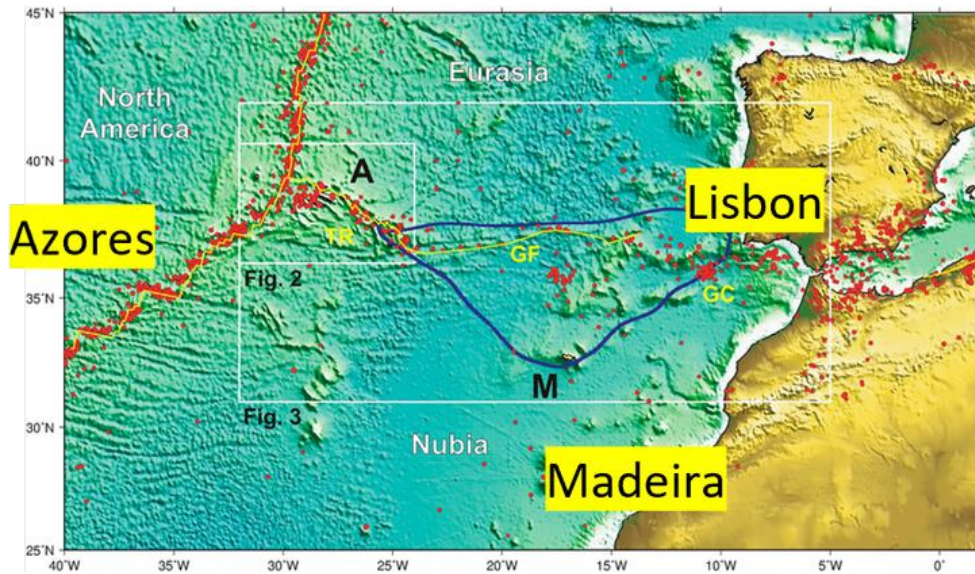

The CAM cable ring (Atlantic CAM — SMART Cables for Ocean Observing).

The Government of Portugal has approved the project and committed \$154 million Euros to fund it. The plan is to start deploying these cables in late 2025 or early 2026.

*c. From the Red Sea to Tennessee: Understanding ecosystems and saving species
Ocean Decade Challenges for collective impact:
#2 Protect and restore ecosystems and biodiversity*

A drop of water that begins its journey flowing along the Tennessee River in the mountains of the Appalachian Highlands will eventually make its way to the sea, where it could end up flowing over a coral reef in the Red Sea.

Like scientists at the [Smithsonian Marine Station \(SMS\)](#) featured in last year’s mission tasks, coral reef researchers at [King Abdullah University of Science and Technology’s Red Sea Research Center \(KAUST RSRC\)](#) are using probiotics to heal diseased coral and promote healthy coral ecosystems. These researchers focus on the premise that healthy organisms and ecosystems rely on healthy microbiomes. This “microbiome stewardship” takes advantage of the fact that microbes are key members of the holobiont (the collective term for a host organism and the variety of other species that live on, near, or within it), connect all ecosystem entities, respond rapidly to manipulation with immediate effects, and are easier to manipulate than macro-organisms.

To support their work on “rehabilitating marine microbiomes,” KAUST RSRC scientists, with help from engineers, technicians, and SCUBA divers, have established a permanent natural laboratory designed for coral reef related research. This “[Coral Probiotics Village](#)” includes underwater pathways, such as Dr.

Octopus Lane and Nemo Street, and study sites where probiotics are administered to coral via syringes as well as via an innovative, automated “probiotics irrigation system.” In addition to delivering probiotics at scheduled intervals, the irrigation system also includes a CTD (conductivity, temperature, depth) and an Acoustic Doppler Current Profiler (ADCP) to capture these essential environmental parameters.



KAUST RSRC's probiotics irrigation system ([Roboto KAUST 2023.pdf - Google Drive](#))

Photogrammetry is another “tool” that coral reef researchers are using to study coral reefs. As shared in the 2023 competition manuals, [photogrammetry](#) is a method of approximating a 3D structure using two dimensional images where photographs are stitched together using software to make the 3D model. It supports scientists by providing an efficient way to characterize coral reef ecosystems as well as monitor future changes in these environments.

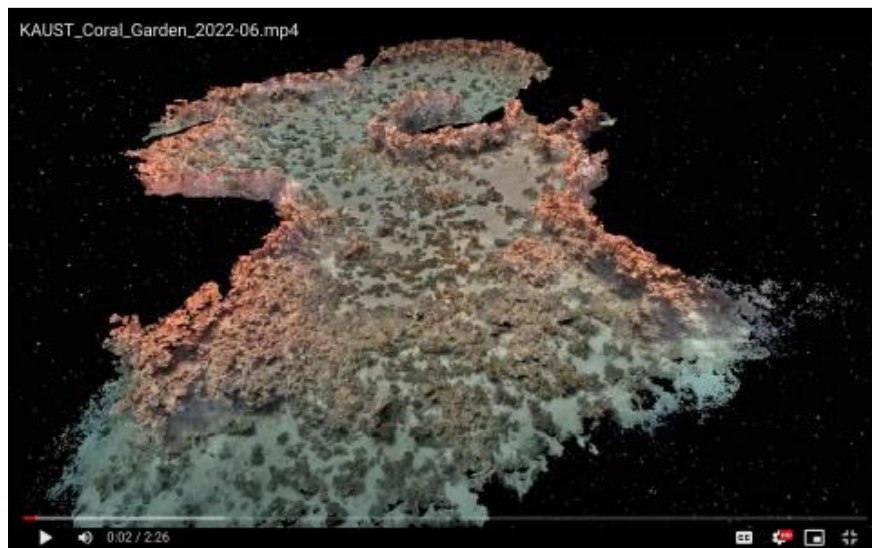

[KAUST Coral Garden photogrammetry fly-through](#)

More than 11,000 kilometers away from KAUST, researchers at the [Tennessee Aquarium](#) are using comparable technologies to save another species – Lake Sturgeon. This prehistoric-looking fish has

remained relatively unchanged since dinosaurs roamed the Earth. Once plentiful in the Tennessee River, Lake Sturgeon populations declined dramatically during the 1900s due to habitat loss caused by the construction of dams, pollution, and overfishing. Since 2000, the Tennessee Aquarium and its partners, which include state, federal, and global organizations such as the Tennessee Valley Authority, the U.S. Fish and Wildlife Service, and the World Wildlife Fund, have reintroduced nearly 250,000 Lake Sturgeon to their native waters in the Tennessee River system.

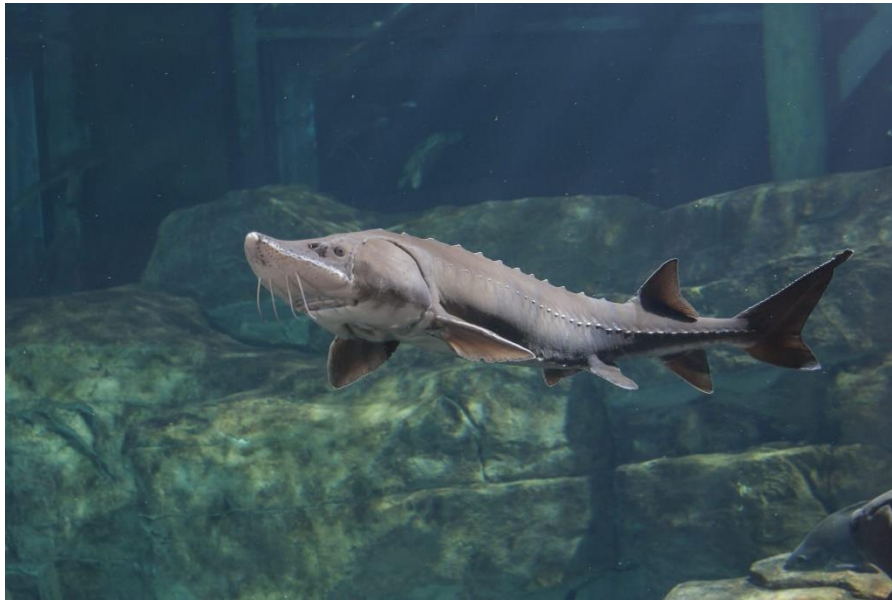

A Lake Sturgeon perusing its exhibit at the Tennessee Aquarium ([Lake Sturgeon · Tennessee Aquarium \(tnaqua.org\)](https://tnaqua.org))

Along with reintroduction, researchers are using observing technologies to learn more about Lake Sturgeon. For example, they have implanted sonic tags into Lake Sturgeon to track their movements in the Tennessee River and deployed acoustic receivers in various locations to help identify potential spawning locations.

From the Red Sea to Tennessee is another reminder of the interconnectivity of our Blue Planet, how changes thousands of miles away from a coastline or thousands of miles away from the open seas can impact each other in either positive or negative ways, and how important observing technologies like CTDs, ADCPs, and acoustic receivers are to understanding ocean and inland aquatic environments and tracking environmental impacts.

Again this year, the UN Decade of the Ocean and the location of the MATE World Championship – along with the focus on observing technologies and the data collection they enable – provide the opportunity to challenge competitors around the globe to recognize that climate change is not limited to oceans and coastal communities; it impacts inland waterways and cities of “Mountain Empire” as well.

d. MATE Floats!

Ocean Decade Challenges for collective impact:

#5 Unlock ocean-based solutions to climate change

The goal of the [National Science Foundation \(NSF\)-funded GO-BGC Project](#) is to build a global network of chemical and biological sensors that will monitor ocean health. Scientists, engineers, and technicians from multiple organizations are using NSF grant funds to build and deploy 500 robotic ocean-monitoring floats around the globe. The temperature, depth, and bio-geochemical information that these floats collect will add significantly to the repository of data needed to better understand ocean processes and predict the consequences of climate change. As of December 2023, nearly 150 GO-BGC floats have been deployed throughout the global ocean.

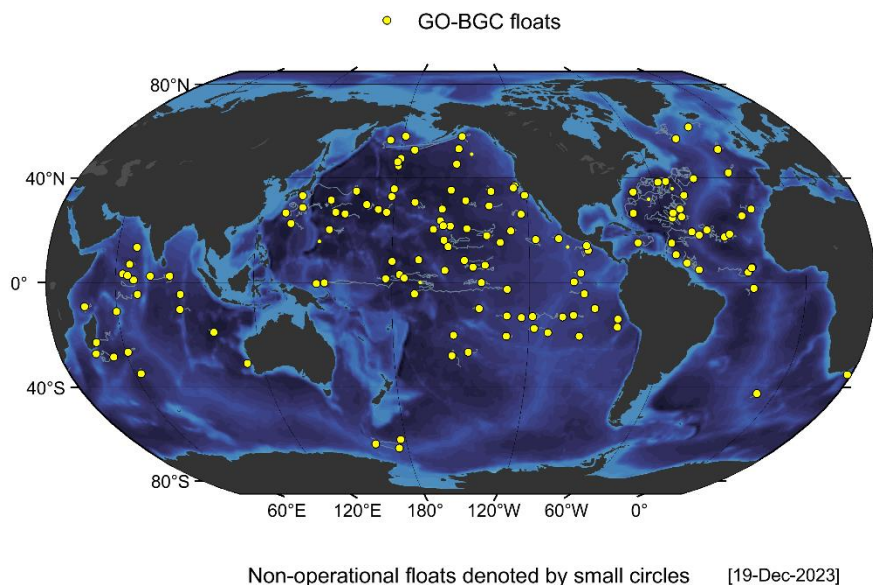

GO-BGC Float locations as of December 19, 2023 ([Array Status | GO-BGC](#)).

These 150 GO-BGC floats joined a larger network of vertical profiling floats that have been circulating the world ocean for more than 20 years. Named after the ship made famous by Jason of Greek mythology, the [Argo float program](#) is an international effort of 30+ countries. Since 1990, the Argo program has deployed nearly 4,000 floats to collect temperature and salinity data and make this data accessible to the global community of researchers, revolutionizing the way information about the ocean is gathered and shared. GO-BGC floats are essentially the next generation of Argo floats, representing a technological evolution in sensor technologies with the development and addition of bio-geochemical sensors – and, most importantly, making the data that these sensors collect part of the repository available to the broader science community.

The MATE ROV Competition’s primary focus is on engineering ROVs. However, the GO-BGC project provides an opportunity to present competitors with the challenge of designing and building another

type of underwater technology, one that contributes to ocean observations and research that is critical to understanding the impact of climate change.



Readying a GO-BGC float for deployment ([GO-BGC | Global Ocean Biogeochemistry Array](#))

THIS IS WHERE YOUR MISSION BEGINS.

2. *Mission Scope and Purpose*

This and the following sections contain the technical specifications and requirements for ROV services needed to support the **OBSERVING OUR OCEANS: UNDERSTANDING OUR WORLD AND CREATING OUR FUTURE**. In 2024, ROV services include:

1) **TASK 1: OOI: Coastal Pioneer Array – Relocating ocean observing assets to “answer pressing science questions and gather data”**

Ocean Decade Challenges for collective impact:

#7 Expand the Global Ocean Observing System

- “Trigger” the release of the multi-function node’s recovery float
- Visually determine failed deployment of recovery float
- Pull pin to release the recovery float to the surface
- Return the recovery float to the surface, side of the pool
- Connect a recovery line to the bale on the multi-function node for ship recovery

- **Manually return the multi-function node to the surface, side of the pool**

2) TASK 2: SMART Cables for Ocean Observing: “Undersea cables connect the planet – what if they could help save it?”

Ocean Decade Challenges for collective impact:

#7 Expand the Global Ocean Observing System

- Deploy SMART cable through three waypoints
- Place SMART repeater in the designated area
- Return SMART cable end to the surface, side of the pool
- Measure the temperature to verify SMART cable sensor readings
- Retrieve a power connector from an AUV docking station
- Install the power connector

3) TASK 3: From the Red Sea to Tennessee: *Understanding ecosystems and saving species*

Ocean Decade Challenges for collective impact:

#2 Protect and Restore Ecosystems and Biodiversity

Smart Reefs

- Place probiotic irrigation system near coral head
- Deploy probiotic sprinkler on coral head
- Activate the irrigation system
- Transplant corals autonomously or manually to the restoration area
- Create a 3D image of the coral restoration area either autonomously, manually (CAD) or manually (paper)
- Measure the length of the coral restoration area and scale the 3D model of the coral
- Determine the height of the coral restoration area

Inland Lakes and Waterways – Sturgeon Restoration

- Recover an acoustic receiver to retrieve its data to determine the location of sturgeon spawning grounds
- Create a graph of sturgeon locations from acoustic receiver data
- Determine the potential spawning site
- Place an ADCP at the potential spawning site
- Recover a sediment sample from the potential spawning site

4) TASK 3: MATE Floats!

UN Sustainable Development Goal:

#13 Climate Action

- Prior to the competition, design and construct an operational vertical profiling float
- Deploy the float in the designated area
- Float communicates with the mission station prior to descending
- Float completes two vertical profiles
- Float communicates data to the mission station
- Data is graphed as depth over time

3. Specifications

See the specific tasks described below as well as the [VEHICLE DESIGN & BUILDING SPECIFICATIONS](#) and [PART 4: COMPETITION RULES](#) sections.

4. Maintenance and Technical Support

The company shall warrant the ROV and associated systems and equipment for at least the duration of the product demonstrations. Repair or replacement shall be at the company's expense, including the cost of shipping the ROV to and from the competition facility.

During regional events, the company shall provide at least one day of technical support to resolve hardware, software, and operational issues. They shall provide at least three days of the same for the World Championship event.

5. Shipping and Storage

Refer to [Shipping Information](#) for specifics on shipping to the MATE World Championship site.

Delivery of the ROV and associated systems and equipment shall be no later than the date of the geographically closest regional contest or by the first day of the MATE World Championship (June 19, 2024).

6. Evaluation Criteria

- a. Technical documentation
- b. Engineering presentation
- c. Marketing display
- d. Company spec sheet
- e. Product demonstration
- f. Safety

7. References

a. GENERAL

- [United Nations Decade of Ocean Science for Sustainable Development](#)
- [17 UN Sustainable Development Goals](#)
- [10 Challenges - Ocean Decade](#)
- [A Hotter Future Is Certain, Climate Panel Warns. But How Hot Is Up to Us](#)
- [ESG \(environmental, social and governance\)](#)
- [What is blue carbon? - Great Barrier Reef Foundation](#)

b. TASK 1: OOI: Coastal Pioneer Array – Relocating ocean observing assets to “answer pressing science questions and gather data”

- [Ocean Observatories Initiative – A new era of oceanography](#)
- [Coastal Pioneer New England Shelf Array – Ocean Observatories Initiative](#)
- [CP04OSPM – Ocean Observatories Initiative](#)
- [OOI Coastal & Global Scale Nodes](#)
- [The Ocean Observatories Initiative](#)
- [Scientific rationale and conceptual design of a process-oriented shelfbreak observatory: the OOI Pioneer Array](#)
- [Coastal Surface Mooring Developments for the Ocean Observatories](#)
- [OOI Data Explorer](#)
- [Forecasting Hypoxia to Support the Dungeness Crab Fishery - Ocean Observatories Initiative](#)

c. TASK 2: SMART Cables for Ocean Observing: “Undersea cables connect the planet – what if they could help save it?”

- [SMART Cables for Ocean Observing](#)
- [Science Monitoring and Reliable Telecommunications \(SMART\)](#)
- [SMART Cables for Observing the Global Ocean: Science and Implementation](#)
- [SMART Subsea Cables for Observing the Ocean and Earth Presentation](#)
- [Marine Technology Society Journal: SMART Subsea Cables for Observing the Ocean and Earth](#)
- [The Seamounts of the Gorrington Bank \(oceana.org\)](#)
- [Charting the Depths: The World of Subsea Cables \(visualcapitalist.com\)](#)

d. TASK 3: From the Red Sea to Tennessee: Understanding ecosystems and saving species

- [allencoralatlas](#)
- [KAUST Reefscape restoration initiative at Shushah](#)
- [Robotic Customized Medicine for Corals](#)
- [Smart Reef and Coastal Sensing Network](#)
- [Exploration Tools: Photogrammetry](#)
- [Holobiont: Definition, Explanation And Examples \(scienceabc.com\)](#)
- [Lake Sturgeon · Tennessee Aquarium](#)
- [Ecoacoustic Monitoring of Lake Sturgeon](#)
- [Sound Production of Spawning Lake Sturgeon](#)
- [Sturgeon Bend](#)

e. TASK 4: MATE Floats!

- [GO-BGC | Global Ocean Biogeochemistry Array](#)
- [Expanding Fleet of Autonomous Floating Robots Targets Deeper Understanding of Global Ocean Dynamics](#)
- [2021 MATE Floats! | MATE ROV Competition Website](#)

- [Adopt-a-Float Newsletters | GO-BGC](#)
- [Argo: A window into the ocean \(arcgis.com\)](#)
- [Argo \(ucsd.edu\)](#)

IMPORTANT NOTE: Questions about production demonstrations and design and building specifications should be sent to the [Competition Technical Manager](#). Question, answers, and official rulings will be posted on the [MATE ROV Competition Q&A and Official Ruling Document](#). This allows all companies to see the questions and answers and helps to avoid duplicate questions. That said, please make sure that your question(s) has not already been asked – and answered – before emailing. It is up to you and your company to read, comprehend, and comply with ALL rulings posted on the site.

WEIGHT RESTRICTIONS

In light of some of the environments in which the ROVs will be operating, an ROV weight requirement has been included in the request for proposals (RFP). Lighter vehicles will be given special consideration and vehicles above a certain weight will not be considered. Size of the ROV will be limited by a 1-meter square opening that companies must launch and recover their vehicle through.

Note for 2024!!!

All weight measurements will include the vehicle and all tools and components. The weight measurement will NOT include the tether. The following will NOT be included in the weight measurement:

- The topside control system and the tether
- The vertical profiling float
- Any independent sensors if removable from the ROV

Vehicles will be weighed in the on-deck circle 15 to 20 minutes prior to the company’s product demonstration run. Note that the vehicle will be weighed before EACH product demonstration run. The weight bonus, if any, will be added to each product demonstration score.

Weight measurements will be conducted using a digital scale. In addition, companies must be able to personally transport the vehicle and associated equipment to the product demonstration station and to the engineering presentation room. ROV systems must be capable of being safely hand launched.

Competition officials will use the following chart to award points for weight:

Weight (in air)	
< 15 kg	+10 points
15.01 kg to 20 kg	+5 points
20.01 kg to 25 kg	+0 points

Vehicles greater than 25 kg in weight will not be allowed to compete in the product demonstration.

Weight Protocol

Only the six designated product demonstration company members will be allowed into the on-deck circle during and after the weigh-in. At the World Championship, two additional members will be allowed to launch and receive data from the vertical profiling float. See Task 4 for more information. Once a company's vehicle has been weighed, it must remain there until the company moves to its product demonstration station. Companies that remove equipment from the vehicle may not re-install that equipment until the 5-minute set up period. At that time, companies may replace any items that were removed for the measurement, but no new equipment (i.e., equipment that was not included in the weight measurements) may be added to the vehicle. If it is discovered that a company added equipment that was not included in the measurements, the company will not be permitted to compete in that product demonstration run.

A video showing a simulated weight measurement is posted [here](#).

PRODUCT DEMONSTRATION

NOTE CHANGES FOR 2024!!!

Companies must launch through a 1-meter square area on the surface, side of the pool. This square will simulate a ship's moon pool/internal launch bay. All items launched and recovered **MUST** go through this 1-meter square.

TASK 1: OOI: Coastal Pioneer Array – Relocating ocean observing assets to “answer pressing science question and gather data”

This task involves the following steps:

1.1 Release the multi-function node

- “Trigger” the release of the multi-function node's recovery float – 10 points
- Visually determine that the recovery float has failed – 5 points
- Pull a pin to release the failed recovery float to the surface – 10 points
- Return the failed recovery float to the surface, side of the pool – 5 points
- Connect a recovery line to the bale on the multi-function node for manual recovery – 20 points
- ~~Manually return the multi-function node to the surface, side of the pool – 5 points~~

Total points = 50 points

Product Demonstration Notes:

Task 1.1 Release the multi-function node

The multi-function node will be located on the bottom of the pool at the start of the product demonstration. The multi-function node will consist of a [plastic milk crate](#), 3-inch pipe holding the 2-

inch pipe recovery float, and ½-inch PVC pipe framework. Companies must first simulate “triggering” an acoustic release by pulling a pin. The pin will be constructed from ½-inch PVC pipe.

Companies will receive 10 points for successfully pulling the pin to release the multi-function node’s recovery float. Successfully pulling the pin is defined as the pin no longer in contact with the ½-inch PVC framework of the multi-function node. The pin is not considered debris and may be left in the pool at the end of product demonstration time.

Once the pin is pulled, the recovery float will deploy. For this product demonstration task, the recovery float will not fully deploy; the deployment will be a failure. The recovery float will not rise all the way to the surface; the float’s rope will be “tangled” causing the float to remain in mid water. “Tangled” will be simulated by the shortened rope that is not long enough for the recovery float to reach the surface. Companies will receive 5 points for visually determining the recovery float has failed to properly deploy. Visually determining the recovery float has failed to deploy is defined as showing the station judge on a video display that the recovery float is no longer in contact with the multi-function node (other than the rope) and that the recovery float has not reached the surface.

When the recovery float rises partially to the surface, a manual release [pin](#) will be revealed. This pin will secure a loop at the bottom end of the float’s rope. Companies will receive 10 points for successfully releasing the failed recovery float to the surface by pulling the pin. Successfully pulling the pin is defined as the pin no longer in contact with the milk crate and the failed recovery float rising to the surface. The pin is not considered debris and may be left in the pool at the end of product demonstration time.

Once released to the surface, companies must return the recovery float to the surface, side of the pool. Companies will receive 5 points for successfully returning the recovery float to the surface, side of the pool. Successfully returning the float is defined as the float out of the pool and placed on the pool deck.

Companies must connect a recovery line to the bale on the multi-function node. The bale will be simulated by a [#310 U-bolt](#). MATE will provide a recovery line, but companies may create and use their own recovery line. The recovery line provided by MATE will be constructed from a [carabiner](#) attached to a ½-inch PVC tee at the end of a rope. Company-built recovery lines may use a device other than a carabiner, but companies must make a secure connection to the U-bolt bale. A secure connection means that the device completely encompasses the U-bolt (a full 360° wrap around the U-bolt) and cannot come loose once it is attached. Companies will receive **20 points** when the recovery line is successfully attached to the bale on the multi-function node. Successfully attaching the recovery line is defined as the carabiner no longer in contact with the ROV and secured to the U-bolt bale on the multi-function node.

Once a recovery line has been secured to the multi-function node, companies may manually recover the multi-function node. Company members may pull the recovery line by hand to retrieve the multi-function node to the surface, side of the pool. Companies will receive 5 points for successfully recovering the multi-function node. Successfully returning the multi-function node is defined as the multi-function node removed from the pool and placed on the pool deck. If a company-built recovery line is not secure and the multi-function node falls to the pool bottom during recovery, companies will

be penalized 5 points. Also, once the multi-function node is no longer secure and drops to the bottom it will be considered debris.

TASK 2: SMART Cables for Ocean Observing: “Undersea cables connect the planet – what if they could help save it?”

This task involves the following steps:

2.1 Deploy SMART cable

- **Deploy SMART cable through three waypoints – up to 20 points**
 - **Deploy SMART cable through two waypoints located on the bottom of the seafloor – 5 points each, 10 points total**
 - **Deploy SMART cable through a waypoint located on top of a seamount – 10 points**
- **Place the SMART repeater in the designated area - 10 points**
- **Return the end of the cable to surface, side of the pool – 5 points**
- **Measure the temperature to check the SMART cable sensor readings**
 - **Within 1°C – 15 points**
 - **Within 2°C – 5 points**
- **Connect the AUV docking station to the SMART cable repeater**
 - **Retrieve the power connector from the AUV docking station – 5 points**
 - **Install the power connector – 15 points**

Total points = 70 points

Product Demonstration Notes:

Task 2.1 Deploy the SMART cable

The SMART cable with one SMART repeater will be located on the surface, side of the pool at the start of the product demonstration. The SMART cable will be constructed from wire with one SMART repeater, which will be constructed from 1 ½-inch PVC pipe attached to the wire. Companies must deploy the SMART cable through three waypoints, two of which will be located on the seafloor and one of which will be located on the top of a seamount. Waypoints will be constructed from ½-inch PVC pipe. The waypoint on top of a seamount will be raised 50 cm above the pool bottom on PVC “legs”. Companies will receive 5 points for successfully deploying the cable through each waypoint on the seafloor, and 10 points for successfully deploying the cable through the waypoint on top of the seamount. Successfully deploying the cable through a waypoint is defined as the wire inside two PVC posts of the waypoint.

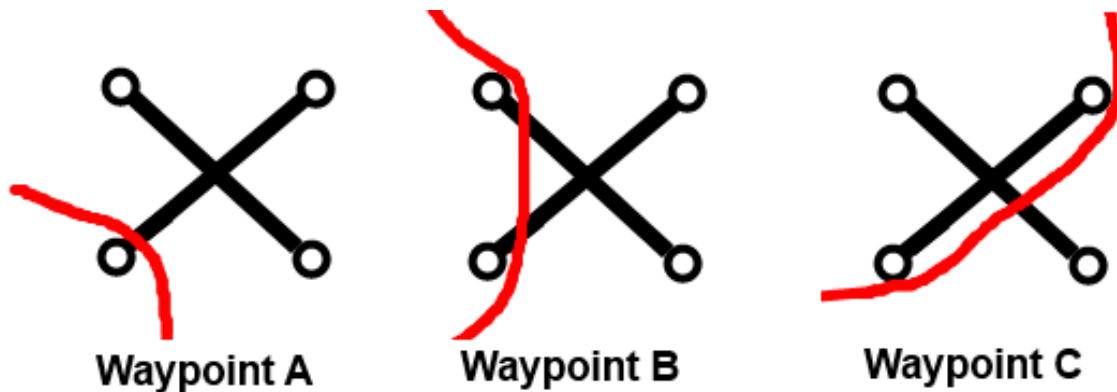

Depiction of successful and unsuccessful cable lying through waypoints. Waypoint A is an unsuccessful cable lay, as the cable is inside one vertical post only. Waypoint B is a successful cable lay, as the cable is inside two vertical posts. Waypoint C is an unsuccessful cable lay, as the cable is only inside one vertical post (the lower right post only).

The wire simulating the SMART Cable will run through a SMART repeater. The SMART repeater will be constructed from 1 ½-inch PVC pipe, a tee, and end caps. A [#6 screw hook](#) will act as a carrying mechanism for the SMART repeater. Companies must place the SMART repeater into a designated area constructed of ½-inch PVC pipe painted blue. Companies will receive 10 points for successfully placing the SMART repeater in the designated area. Successfully placing the SMART repeater in the designated area is defined as the 1 ½-inch PVC pipe of the repeater no longer in contact with the ROV and completely inside the designated area.

The SMART repeater will weigh less than 10 Newtons in water.

Once the SMART cable is deployed through all three waypoints and the SMART repeater is placed in the designated area, the end of the cable must be returned to the surface side of the pool. Companies will receive 5 points for successfully returning the cable end to the surface, side of the pool. Successfully returning the cable end is defined as the wire successfully deployed through all three waypoints, the SMART repeater successfully placed in the designated area, and both ends of the wire on the surface, side of the pool.

Once the SMART repeater has been successfully placed in the designated area, companies must check the SMART repeater temperature sensor readings. The SMART repeater will include a MATE ROV Competition temperature sensor; the wires for the temperature sensor will run alongside the rope. Companies must measure the temperature at the SMART repeater's temperature sensor to check the temperature sensor is working. Companies will receive 15 points if their temperature sensor is within 1°C of the SMART cable's temperature reading. Companies will receive 5 points if their temperature sensor is between 1.01°C and 2°C of the SMART cable's temperature reading. Companies must show the judge their temperature sensor readout, but they may include an adjustment or offset, if needed. Companies should inform the judge of any adjustment or offset prior to showing the judge their temperature measurement.

Companies can calibrate their temperature sensor with the MATE ROV Competition temperature sensor during the 5-minute set up period or during the 15-minute product demonstration run. When the SMART repeater is on the surface, the station judge will allow the company to view the MATE ROV Competition temperature readout. The SMART repeater will be on the surface, side of the pool at the start of the product demonstration run, and companies may compare their ROV's temperature sensor to the readout of the MATE ROV Competition temperature sensor to determine if there is an offset. Companies can then apply that offset to their temperature reading when the SMART repeater is placed in the designated area. Companies may place both their ROV and the SMART repeater in the water to obtain a temperature reading in the water. However, companies can only calibrate their temperature sensor while on the surface. Once the ROV is deployed to start or resume the product demonstration run, the MATE ROV Competition temperature readout will no longer be available for calibration.

Once the SMART repeater has been successfully placed in the designated area, companies must connect a nearby AUV docking station to the SMART repeater. The AUV docking station will be constructed from ½-inch PVC pipe. The connector will be located on a corrugated plastic sheet platform on the AUV docking station. The connector will be constructed from ½-inch PVC pipe. A [#6 screw hook](#) will act as a carrying mechanism for the connector. A [rope](#) will be coiled on the platform with the connector and attach the connector to the AUV docking station. Companies will receive 5 points for successfully retrieving the power connector from the AUV docking station. Successfully retrieving the connector is defined as the connector under control of the ROV and no longer touching the platform or the AUV docking station.

The AUV docking station connector will weigh less than 5 Newtons in water.

Once the connector has been retrieved from the AUV docking station, it must be installed into the SMART repeater. The SMART repeater construction will include a 1 ½-inch tee. Companies must install the connector into the middle opening of the 1 ½-inch tee. The inside surface of the 1 ½-inch tee opposite the middle opening will have a 5 cm x 5 cm square of Velcro loops attached to it. The attachment end of the connector will be covered with Velcro hooks. Companies will receive 15 points when the connector is successfully installed into the SMART repeater. Successfully installing the connector is defined as the connector no longer in contact with the ROV, the connector inserted into the middle opening of the 1 ½-inch PVC tee on the SMART repeater, and the connector making a Velcro-to-Velcro stick.

Note that in order to complete the temperature measurement or connect the AUV docking station, the SMART repeater MUST be successfully placed in the designated area.

TASK 3: From the Red Sea to Tennessee: Understanding ecosystems and saving species

This task involves the following steps:

Smart Reefs

3.1 Probiotics 2

- **Place a probiotic irrigation system in the designated location – 10 points**

- Deploy the probiotic sprinkler on coral head – 10 points
- Activate the irrigation system – 10 points

3.2 Coral Restoration

- Transplant branching coral – 10 points
- Transplant brain coral
 - Autonomously – 30 points
 - Manually – 10 points

3.3 3D Coral Modelling

- Via photogrammetry, autonomously create a scaled 3D model of the coral restoration area – up to 40 points
 - Create a 3D model of the coral restoration area – 20 points
 - Measure the length of the coral restoration area (within 5 cm) – 10 points
 - Scale the 3D model using the length of the coral restoration area – 5 points
 - Use the properly scaled 3D model to estimate the height of the coral restoration area (within 5 cm) – 5 points

Or

- Manually (CAD) create a scaled 3D model of the coral restoration area – up to 30 points
 - Measure the length of the coral restoration area (within 5 cm) – 10 points
 - Measure the height of the coral restoration area (within 5 cm) – 10 points
 - Create a scaled 3D model of the coral restoration area displaying the length and height measurements – 10 points

Or

- Manually (paper) create a 3-view technical drawing of the coral restoration area – up to 20 points
 - Measure the length of the coral restoration area (within 5 cm) – 5 points
 - Measure the height of the coral restoration area (within 5 cm) – 5 points
 - Create a technical drawing on paper of the coral restoration area, including the measured length and height measurements with at least 3 views (top, front, and side) – 10 points

Tennessee Lakes and Rivers

3.4 Determine the location of sturgeon spawning grounds

- Recover an acoustic receiver – 10 points
- Determine the location of a potential spawning site
 - Create a graph of sturgeon locations from the acoustic receiver data – 15 points
 - Determine the potential spawning site – 5 points
- Characterize the habitat at potential spawning site
 - Place an ADCP – 10 points
 - Recover a sediment sample – 10 points

Total points = 160 points

Product Demonstration Notes:

Task 3.1 Probiotics 2

Companies must place the probiotic irrigation system in the designated location. The probiotic irrigation system will be located on the surface, side of the pool at the start of the product demonstration. The irrigation system will be constructed from ½-inch PVC pipe and 3-inch pipe. A [#310 U-bolt](#) will act as a carrying mechanism for the irrigation system. A length of [clear vinyl tubing](#), the probiotic sprinkler, will be attached to and hang from a [#6 screw hook](#) on the irrigation system. The designated location will be constructed from ½-inch PVC pipe painted yellow. Companies must place the irrigation system in the designated location. Companies will receive 10 points for successfully placing the irrigation system in the designated location. Successfully placing the irrigation system in the designated location is defined as the irrigation system no longer in contact with the ROV and completely within the PVC pipe of the designated location.

The irrigation system will weigh less than 15 Newtons in water.

Companies must place the probiotic sprinkler over a branching coral within the coral restoration area. The coral restoration area will be constructed of ½-inch PVC pipe with corrugated plastic sheeting attached to the top. A branching coral will be located at the top of the coral restoration area. Companies must remove the probiotic sprinkler from the hook on the irrigation system and place the sprinkler over the branching coral. Companies will receive 10 points when the probiotic sprinkler is successfully placed over the coral head. Successfully placing the sprinkler is defined as the sprinkler no longer in contact with the ROV and completely over all branches of the coral head.

Once the probiotic sprinkler is placed over the coral head, companies must activate the irrigation system. A [½-inch brass stop valve](#) will be incorporated into the ½-inch PVC pipe of the irrigation system. A ½-inch cross with PVC pipe will be attached to the handle of the stop valve; one length of PVC pipe will be painted yellow. Companies must turn the stop valve 360° clockwise to activate the irrigation system. Companies will receive 10 points for successfully activating the irrigation system. Successfully activating the irrigation system is defined as showing the station judge on a video screen that the handle on the gate valve is turned 360°.

The stop valve will take less than 5 Newtons to turn.

Note that companies must successfully place the probiotic sprinkler over the coral head before activating the irrigation system.

Task 3.2 Coral Restoration

Companies must transplant one branching coral and one brain coral from the coral nursery to the coral restoration area. Note that this branching coral is different from the branching coral on top of the coral restoration area and will be constructed from ½-inch PVC pipe. A [3/8-inch, 2 ½-inch hex bolt](#) will be attached inside the ½-inch pipe of the branching coral. The brain coral will be constructed from a [plastic bowl](#) with a rope carrying mechanism attached. The nursery will be constructed from ½-inch PVC pipe with a corrugated plastic sheet top. The branching coral will sit upright on the nursery, with the 3/8-inch

bolt sitting loosely in an upright section of the ½-inch pipe on the nursery. The brain coral will sit on a corrugated plastic sheet.

Companies must transplant the branching coral into the holder on the coral restoration area. A section of 1-inch PVC pipe will rise vertically from the coral restoration area. Companies must insert the branching coral into the 1-inch PVC pipe. Companies will receive 10 points for successfully transplanting the branching coral fragment. Successfully transplanting the coral is defined as the 3/8-inch bolt of the coral fragment positioned inside the vertical 1-inch pipe and the PVC pipe of the coral fragment in contact with the vertical 1-inch pipe of the designated area. The coral fragment(s) must remain successfully transplanted into the coral restoration area for the entire product demonstration run. If the coral fragment is displaced from the designated area at any time during the product demonstration run, the company will not receive points for successfully transplanting the coral fragment. If a coral fragment is displaced from the designated area, companies may attempt to transplant the coral fragment again.

Companies must also transplant brain coral into the restoration area. The brain coral will have Velcro loops on the underside of the bowl. The restoration area will have a 15 cm square area of [red Velcro hooks](#) on a horizontal corrugated plastic sheet surface. Companies must transplant the brain coral from the nursery area to the restoration area. The brain coral may be transplanted autonomously or manually.

Companies choosing to transplant the brain coral autonomously are tasked with creating software that will allow their vehicle to autonomously transplant the brain coral from the nursery area to the coral restoration area. Companies that successfully transplant brain coral using an autonomous control program will receive 30 points. Successfully transplanting the brain coral autonomously is defined as the control program moving the vehicle from the coral nursery to the coral restoration area and placing the brain coral on the red Velcro square. Any portion of the bottom of the brain coral may be touching any portion of the red Velcro square. During transplantation, no company member should be touching the controls or other systems. The pilot may manually pick up the brain coral from the coral nursery, but once the brain coral is no longer in contact with the nursery, all movement of the vehicle must be autonomous. A tether manager may hold the tether but cannot guide the vehicle in any way. Companies attempting to transplant the brain coral autonomously should inform the station judge that they are doing so prior to picking up the brain coral. If a company cannot successfully transplant the brain coral onto the Velcro square, they may attempt to do so manually. Companies will get one attempt at performing the task autonomously. If at any time after picking up the brain coral the company must take manual control, they cannot get points for autonomous transplanting. Companies should inform the station judge when they switch to manual transplanting of the brain coral.

Companies completing the task autonomously must provide their autonomous software control program and an explanation of that program to MATE ROV Competition officials prior to the competition. See [PART 6: SUBMISSION GUIDELINES AND KEY DEADLINES](#) for more information. Regional competitions may not require submission of the software control program. Contact [your regional coordinator or visit your regional contest's website](#) to determine whether you are required to turn in your autonomous control software.

Companies choosing to transplant the brain coral manually may pilot the vehicle to pick up the brain coral and transplant it into the coral restoration area. Companies that successfully transplant the brain coral manually will receive 10 points. Successfully transplanting the brain coral manually is defined as the vehicle, under control of the pilot, placing the brain coral on the red Velcro square. Any portion of the bottom of the brain coral may be touching any portion of the red Velcro square.

Task 3.3 3D Coral Modelling

Companies must measure the length of the coral restoration area and create a 3D model of the restoration area. The coral restoration area will be constructed from ½-inch PVC pipe, will be between 1 meter and 2.5 meters in length, 36 cm wide and an unknown height. A branching coral located at the top of the restoration area will add to its height.

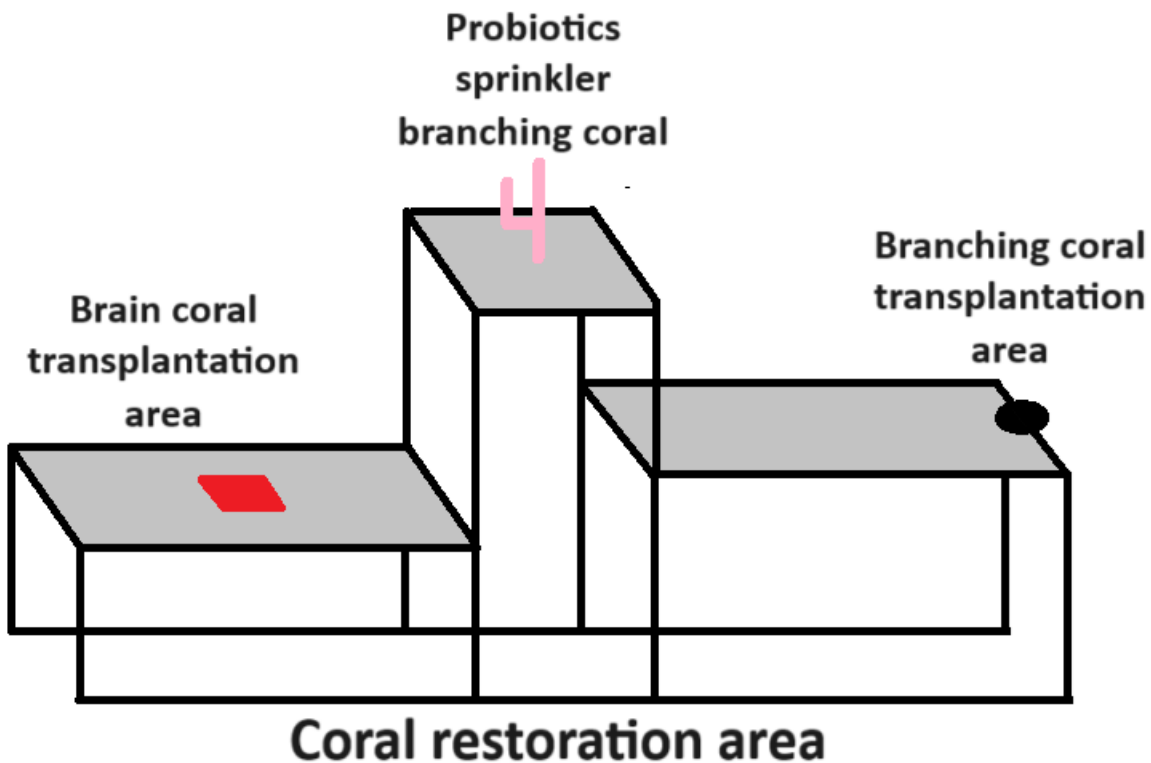

Companies choosing to create a 3D model of the coral restoration area autonomously must use photogrammetry to create a 3D model of the coral restoration area in a CAD program with the proper dimensions displayed. Companies may manually maneuver around the coral restoration area to take photos. Companies may transfer any images from the ROV to a computer or device at the mission station. This transfer does not have to be done autonomously; it can be accomplished "by hand." Companies are allowed to place an object of known dimensions (ruler) on or near the coral restoration area to assist in the measurements. Note that this object of known dimensions would count as debris if it is not under control of the ROV or removed from the pool by the end of product demonstration time.

Companies will receive 20 points for modeling the coral restoration area successfully in a CAD program. Successfully modeling the coral restoration area via photogrammetry is defined as the restoration area

displayed as a 3D image on a screen at the product demonstration station. The image should be able to be rotated so that the station judge can view it from any angle. The 3D image must show the branching coral on top of the coral restoration area, but other nearby objects from other coral reef tasks are optional to show in the 3D model. The irrigation system and sprinkler do not need to be shown in the model, but they could be if the photos are taken after the sprinkler system has been deployed. Likewise, the branching coral and brain coral transplanted onto the coral restoration area do not need to be shown in the model, but those corals could also be shown if the photos are taken after they have been transplanted. Neither the sprinkler nor transplanted corals will add to the overall length or height of the coral restoration area and including them in the 3D model will not affect scoring of this product demonstration task.

Companies must also measure the length of the coral restoration area and use that length to scale the 3D image accordingly. Companies will receive 10 points for successfully measuring the length of the coral restoration area. Successfully measuring the length of the coral restoration area is defined as the company measurement being within 5 cm of the true length. Companies must show the station judge their measurement or explain how they are estimating the measurement. Companies may not guess at the length measurement. Once the company provides their length measurement (regardless if it is within 5 cm), the station judge will provide the company with the actual length of the coral restoration area. A company that does not attempt to measure the length will not receive the actual length of the coral restoration area from the station judge and therefore cannot complete the scaling or height estimation steps.

Companies should use the actual length provided by the station judge to scale their 3D model of the coral restoration area. Companies will receive 5 points for successfully scaling their 3D model and displaying the length measurement on that model. Successfully scaling the model and displaying the length is defined as the station judge being able to see the length displayed on the 3D model.

Using the scaled length of the 3D model, companies must estimate the height of the coral restoration area. The height includes the height of the branching coral on top of the area. Companies will receive 5 points when they successfully estimate the height of the coral restoration area within 5 cm. Successfully estimating the height of the coral restoration area is defined as using the 3D image properly scaled for length to determine the height. The station judge must be able to see the height displayed on the 3D model, and that height must be within 5 cm of the true height.

Companies choosing to create a 3D model of the coral restoration area manually using CAD must first measure the length and height of the area.

Companies must measure the length and height of the coral restoration area. Companies will receive 10 points for successfully measuring the length of the coral restoration area. Companies will receive 10 points for successfully measuring the height of the coral restoration area. Successfully measuring the length and height of the coral restoration area is defined as the company measurement being within 5 cm of the true length or true height. Note that the approximate width of the coral restoration area will be known from the building specifications. Companies must show the station judge both of their measurements or explain how they are estimating the measurement. Companies may not guess at the

length or height measurement. Companies are allowed to place an object of known dimensions (ruler) on or near the coral restoration area to assist in the measurements. Note that this object of known dimensions would count as debris if it is not under control of the ROV or removed from the pool by the end of product demonstration time.

Companies should then create a 3D model of the coral head in a CAD or other program. Companies may input their measurements manually into a CAD or other program to create their 3D model. The length and height measurements should be included in the 3D model, even if those measurements were incorrect. Companies will not receive points for properly measuring the dimensions of the coral restoration area but can still receive points for modeling the area with the measurements taken.

Companies will receive 10 points for successfully modeling the 3D coral restoration area. Successfully modeling the restoration area is defined as the model of the restoration area displayed as a CAD model on a screen at the station and the length and height dimensions included on the model. The 3D model should be able to be rotated and viewed from any angle. The length and height dimensions measured by the company must be included on the model.

The 3D model must include:

- The coral restoration area
- The branching coral at the top of the coral restoration area. This coral may be depicted as a single vertical cylinder.

The 3D model does not need to include:

- The branching coral or brain coral transplanted into the coral restoration area
- The 1-inch pipe holder for the branching coral transplant
- The red Velcro square
- The ½-inch PVC pipe stabilizers that hold the coral restoration area upright
- The probiotic irrigation system or sprinkler
- The designated area for placing the probiotic irrigation system

Companies choosing to create a 3D model of the coral restoration area manually on paper must first measure the length and height of the coral restoration area.

Companies must measure the length and height of the coral restoration area. Companies will receive 5 points for successfully measuring the length of the coral restoration area. Companies will receive 5 points for successfully measuring the height of the coral restoration area. Successfully measuring the length and height of the coral restoration area is defined as the company measurement being within 5 cm of the true length or true height. Note that the approximate width of the coral restoration area will be known from the building specifications. Companies must show the station judge both of their measurements or explain how they are estimating the measurement. Companies may not guess at the length or height measurement. Companies are allowed to place an object of known dimensions (ruler) on or near the coral restoration area to assist in the measurements. Note that this object of known dimensions would count as debris if it is not under control of the ROV or removed from the pool by the end of product demonstration time.

Once the measurements are taken, companies must create a technical drawing consisting of three views – front, top and side – of the coral restoration area. The front view must include the length and height measurements, width does not need to be included on the technical drawing. Companies will receive 10 points for successfully creating the technical drawing of the coral restoration area. Successfully creating a technical drawing is defined as all three views shown to the station judge. The front view must include both the length and height measurements taken by the company, even if those measurements were incorrect. Companies will not receive points for the proper measurements but will receive points for the technical drawing.

The technical drawing must include:

- The coral restoration area
- The branching coral at the top of the coral restoration area. This coral may be depicted as a single vertical cylinder.

The technical drawing does not need to include:

- The branching coral or brain coral transplanted into the coral restoration area
- The 1-inch pipe holder for the branching coral transplant
- The red Velcro square
- The ½-inch PVC pipe stabilizers that hold the coral restoration area upright
- The probiotic irrigation system or sprinkler
- The designated area for placing the probiotic irrigation system

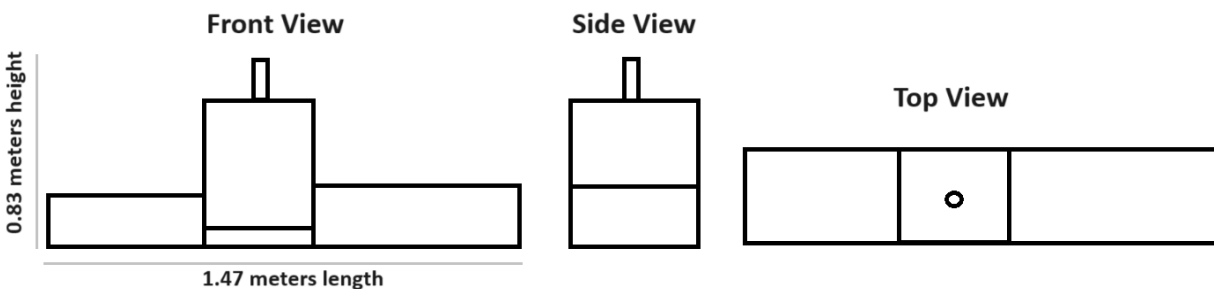

Technical drawing of a coral restoration area showing a front view, side view, and top view.

The MATE ROV Competition will not provide paper. Companies planning to create a technical drawing should bring their own paper. All work must be done at the mission station and during the production demonstration time.

NOTE: Companies will only receive points for one method of modeling the coral restoration area. However, companies may attempt more than one method. For example, a company could create a technical drawing of the coral restoration area quickly while a computer program works to autonomously create a 3D model. If the program is successful at creating the model autonomously, the company would receive 40 points. But if the program is not successful, the company would still receive 20 points for successfully creating a technical drawing.

Tennessee Lakes and Rivers

Task 3.4 Determine the location of sturgeon spawning grounds

Three acoustic receivers will be located in three different potential spawning locations on the bottom. Companies must recover one acoustic receiver. The acoustic receivers will be constructed from ¾-inch and ½-inch PVC pipe. Companies will receive 10 points when they successfully recover one acoustic receiver. Successfully recovering one acoustic receiver is defined as the acoustic receiver out of the water and placed on the pool deck.

The acoustic receiver will weigh less than 10 Newtons in water.

Once the acoustic receiver has been recovered, companies will receive a table that contains data on sturgeon spawning sounds (also known as “sturgeon thunder”) from the mission station judge. NOTE: If the mission station judge does not immediately provide this table, companies should request it. This table will include data from all three acoustic receivers collected over 15 days. The data will be printed on a laminated sheet. The data may also be provided as a .csv file on a USB 2.0 thumb drive. Contact your [regional coordinator](#) or check your regional information document for more information on how the data will be available at the mission station.

Companies must use this data to create a graph of the number of sturgeon in each location over the course of 15 days. Companies will receive 15 points for successfully creating a graph of the data. Successfully creating a graph is defined as showing the station judge a graph with all 45 data points plotted as 3 receivers, each containing 15 data points. How companies graph the data is up to them, but the graph should logically show sturgeon numbers from all three acoustic receivers. The graph must be titled and must have both axes labeled (# of sturgeon, day #).

Day	# of sturgeon														
	1	2	3	4	5	6	7	8	9	10	11	12	13	14	15
Receiver 1	3	3	0	0	1	1	1	1	3	2	0	2	3	2	0
Receiver 2	4	3	8	8	13	10	8	4	3	1	2	1	0	1	2
Receiver 3	3	2	5	6	3	2	3	3	2	2	3	2	1	0	1

A table showing the sturgeon data recovered from the acoustic receivers. The data represents the number of sturgeon detected per day at each acoustic receiver.

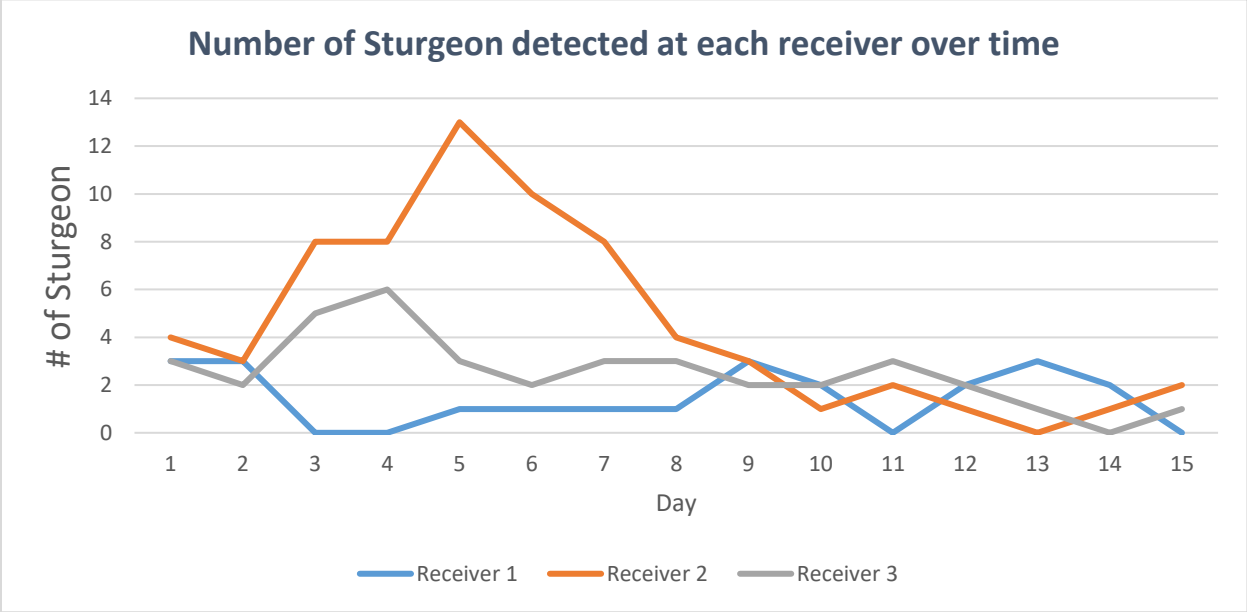
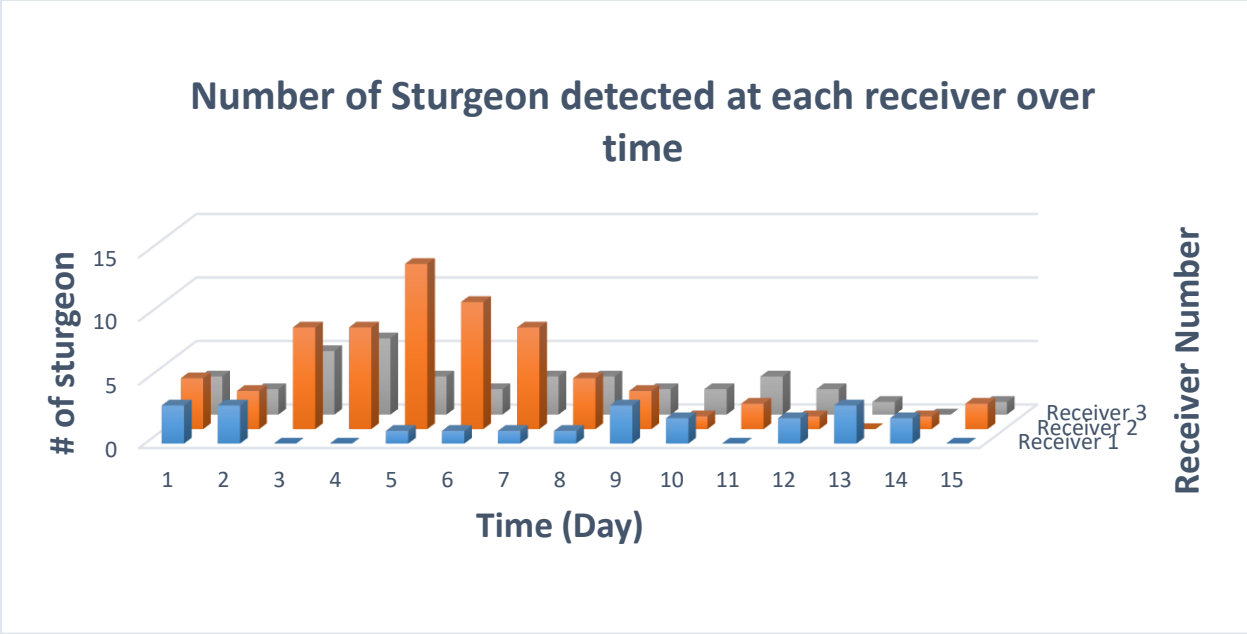

Two graphs displaying sturgeon numbers for each day at three different acoustic receivers. Either graph would successfully display the sturgeon locations from the acoustic receiver data.

Companies must then use their graph to determine the potential sturgeon spawning site, which is the location that has the highest number of sturgeon over a five-day period. Companies will receive 5 points when they successfully determine the potential spawning site. Successfully determining the potential spawning site is defined using the graph to communicate to the station judge the highest concentration of sturgeon over a 5-day period. Companies must use the graph, and not the raw data, to determine the potential spawning location. For example, from either of the example graphs above, companies would select the Receiver 2 location as the spawning site, identifying Day 3 through 7 as the highest number of sturgeon, and communicate this to the station judge while showing the judge their graph.

Companies must place an [Acoustic Doppler Current Profiler](#) (ADCP) in the designated location at the potential spawning site. Note: Although the data has three potential sites for the sturgeon spawning, there will only be one designated location. The designated location will be constructed of ½-inch PVC pipe painted orange. The ADCP will be constructed of ½-inch PVC and 2-inch PVC pipe and will be available at the surface, side of the pool at the start of the product demonstration run. Companies must place the ADCP in the designated location. Companies will receive 10 points for successfully placing the ADCP in the designated location. Successfully placing the ADCP in the designated location is defined as the ADCP no longer in contact with the ROV and the ½-inch base completely inside the designated area.

Companies must collect a sediment sample at the potential spawning site. The sediment will be simulated by [Mexican Beach Pebbles](#), which are rounded black rocks approximately 1-inch to 2-inch in maximum length. The Mexican Beach Pebbles will be located in a ½-inch PVC rectangle adjacent and attached to the designated area for the ADCP. There will be at least five rocks, possibly more, in the rectangle. Companies must recover one rock to the surface, side of the pool. Companies will receive 10 points for successfully recovering the sediment sample. Successfully recovering the sediment sample is defined as at least one rock being returned to the surface, side of the pool and placed on the pool deck.

NOTE: Companies do not need to determine the potential spawning site before placing the ADCP and collecting the sediment sample. These tasks are independent of determining the potential spawning location.

TASK 4: MATE Floats!

MATE Floats! 2024 is inspired by the National Science Foundation (NSF)-funded GO-BGC Project. The goal of GO-BGC is to help build a global network of profiling floats with chemical and biological sensors to monitor circulation, chemistry, biology, and overall ocean health. Scientists, engineers, and technicians are using NSF grant funds to build and deploy 500 robotic ocean-monitoring floats around the globe.

This task involves the following steps:

4.1 Design and construct an operational vertical profiling float

- **Prior to the competition, design and construct a vertical profiling float – 5 points**
- **Deploy the float into a designated area – 5 points**
- **Float communicates with the mission station prior to descending – 10 points**
- **Float completes up to two vertical profiles –**
 - **Vertical profile 1**
 - **Float completes first vertical profile**
 - **Using a buoyancy engine – 10 points**
 - **Using a different mechanism – 5 points**
 - **Float communicates data to the mission station – 5 points**
 - **Data is graphed as depth over time – 10 points**
 - **Vertical profile 2**

- Float completes a second vertical profile
 - Using a buoyancy engine – 10 points
 - Using a different mechanism – 5 points
- Float communicates data to mission station – 5 points
- Data is graphed as depth over time – 10 points

OR

Company does not design and construct a vertical profiling float or float does not communicate data to the mission station.

- MATE-provided data is used to graph depth over time – 10 points

Total points = 70 points

Product Demonstration Notes:

Task 4.1 MATE Floats!

Prior to the competition, companies must build a float capable of completing a vertical profile (i.e., traveling from the surface to the bottom and back to the surface) and collecting and communicating data to the mission station.

Companies that design their float with a buoyancy engine will receive additional points. A [buoyancy engine](#) moves fluid from inside the float to outside the float, displacing seawater and changing the density of the float. Using a motor to change the volume (push or pull a syringe, pump water into or out of, or expand a section) of the float constitutes "using a buoyancy engine". Using thrusters to directly move the float constitutes "using a different mechanism." Companies that do not use a buoyancy engine to complete their vertical profiles will receive fewer points. The float must also be capable of communicating data to a receiving device (i.e., the receiver) located at the surface at the mission station. The company is responsible for designing and constructing both the transmitter on the float and the receiver that displays the data at the mission station.

Companies must submit a one-page Non-ROV device document outlining their float design, detailing its operation, including the mechanism the float uses to descend/ascend (e.g., a buoyancy engine, thruster, or other), and demonstrating that it does not violate any safety rules. This document must also detail how the float communicates with the company's receiver at the mission station. This Non-ROV device document must be submitted in advance of the competition. Companies will receive 5 points for designing and building a float. Successfully designing and building a float is defined as submitting a non-ROV device document and transporting the float to the product demonstration station.

Companies competing at a regional may or not be required to submit float documentation. [Contact your regional coordinator or visit your regional contest's website](#) to determine if you must submit your float design document prior to the competition. See DOC-004 in the competition manual for more information. IF REQUIRED BY THE REGIONAL COMPETITION, COMPANIES MUST SUBMIT THEIR FLOAT

DOCUMENTATION OR THEY WILL NOT BE RECEIVE POINTS FOR BUILDING THE FLOAT. Companies MUST present a copy of the float documentation to the station judges.

Companies must deploy their float in a designated location. The designated location is defined as anywhere beyond a green mark set 2.5 meters out in the pool. Companies will receive 5 points when they successfully deploy their float. Successfully deploying the float is defined as the float no longer in contact with the ROV, floating on the surface, and beyond the green mark 2.5 meters away from the side of the pool. If the float is released before reaching the designated location, companies are permitted to retrieve the float and reposition it in the designated location. However, if the float is released and begins communicating with the mission station receiver before reaching the designated area, companies may choose to disregard those communications and reposition the float in the designated area. Once deployed in the designated area, the float must communicate with the mission station to receive points for communication. Alternatively, if the float communicates with the mission station prior to being deployed in the designated location, companies may choose to opt out of points for deploying the float and instead receive points for communication prior to descending. Once the float begins its first vertical profile, or descends below the surface on its own, companies may no longer retrieve the float for repairs or repositioning.

Once the float has been deployed, it must communicate to the receiver located on the surface at the mission station. Companies are responsible for constructing both the transmitter on the float and the receiver at the mission station. Companies should design their float so that the transmitter can be maintained high enough above the surface of the water to communicate with the mission station.

The float must communicate (i.e., transmit) the following information to the mission station, referred to as the defined data packet:

- Company number (provided by MATE a few weeks prior to the competition)
- Time data (UTC or local or float time [float time would be time since float starts recording])
- Pressure data
- Depth data (optional)
- Any additional data as required by the company to complete this task

If a pressure to depth conversion is completed by the sensor on the float, companies may transmit depth data as part of their defined data packet. Alternatively, companies may choose to only transmit pressure data as part of their defined data packet and convert pressure to depth at the mission station.

Pressure data must be displayed in pascals (pa) or kilopascals (kpa).

Depth data must be displayed in meters (m) or centimeters (cm).

Pressure data (and depth data if transmitted) must correlate to a set time transmitted from the float.

For example, a defined data packet from EXPLORER 01 could be:

EX01 1:51:40 UTC 9.8 kpa 1.00 meters

NOTE: MATE is requiring WHAT data is transmitted (i.e., company number, time, pressure, depth). Companies must determine HOW to transmit that data and should consider that there will be other companies transmitting data at same time.

While on the surface and determined to be successfully deployed by the ROV, and before completing its first vertical profile, the float must transmit the defined data packet to the receiver; the receiver should not receive transmissions from any source other than the float.

Companies will receive 10 points when their float successfully transmits the defined data packet to the receiver at the mission station upon deployment. Successfully transmitting the information is defined as the station judge seeing the defined data packet from the float on a screen or display at the mission station. The float only needs to transmit one defined data package prior to descending, but companies will not be penalized for sending additional defined data packets.

The screen or display showing the defined data packets is not considered a video display for the purposes of number of video displays allowed.

The float should attempt to complete two vertical profiles. A vertical profile is defined as any part of the float on or above the surface, descending in the water column until any part of the float touches the bottom, then ascending to and breaking the surface once again. Companies may use a buoyancy engine, thrusters, or another means to move their float through the water. A buoyancy engine is defined as moving air or liquid from inside the float to outside the float, changing the volume and thus the density of the float. Using motors to move air or liquid does constitute a buoyancy engine. Using motors as thrusters to directly move the float, by turning a propeller or emitting a jet of water, constitutes using a different mechanism to complete a vertical profile. Companies will receive 10 points for completing their first vertical profile using a buoyancy engine, or 5 points if they use a different mechanism.

During the first vertical profile, the float must collect data every 5 seconds. After the first vertical profile has been completed and the float is still at the surface, the float must transmit all defined data packets taken every five seconds to the mission station receiver. Companies will receive 5 points when the float successfully communicates to the mission station receiver. The float MUST have completed one vertical profile to receive points for transmitting defined data packets to the receiver. Successfully transmitting data to the receiver is defined as the station judge seeing the defined data packets from the float on a screen or display at the mission station.

Companies must use the defined data packet to graph the depth over time. How and when companies convert their pressure reading to a depth measurement is up to them. The sensor onboard the float may perform internal conversions and transmit both pressure and depth, companies may convert pressure to depth on their surface receiver device, or companies may use a different device at the station to convert pressure to depth.

Companies will receive 10 points for graphing depth versus time. Successfully graphing the data is defined as showing the station judge a graph with time on the X-axis and depth on the Y-axis. Depth

data should be graphed every 5 seconds. The depth should be measured from the bottom of the float. If the pressure sensor is not located at the bottom of the float, companies may use a conversion factor. Communicate to the station judge any conversion factor incorporated into your depth data. Companies should also communicate to the station judge how far below the waterline the pressure sensor is when on the surface. For example, if the pressure sensor is 10 cm from the bottom of the float and 20 cm from the waterline when on the surface, companies should let the station judge know that a depth reading of 2.4 meters is actually 2.5 meters actual depth. When on the surface, companies should inform the judge that their float will read 30 cm of depth (20 cm from waterline to pressure sensor, 10 cm from pressure sensor to the bottom of the float). Station judges will compare the depths provided on the graph when the float is on the surface and on the bottom to known depths. Company's depths must be within 25 cm of the true depth to receive points for successfully graphing the data.

Companies must use a computer or device to graph the data; companies may not draw a graph by hand. Data points may be entered (or cut and pasted) to a device by hand. Companies are not required to autonomously generate a graph of depth versus time.

The float should then attempt to complete a second vertical profile. Companies will receive 10 points for completing a second vertical profile using a buoyancy engine, or 5 points if they use a different mechanism.

During the second vertical profile, the float should continue to collect data every 5 seconds. After the second vertical profile has been completed and the float is still on the surface, the float must transmit all defined data packets taken every five seconds to the mission station receiver. Companies will receive 5 points when the float successfully communicates to the mission station receiver. The float MUST have completed a second vertical profile to receive points for transmitting defined data packets to the receiver. Successfully transmitting data to the receiver is defined as the station judge seeing the defined data packets from the float on a screen or display at the mission station.

Companies must use the defined data packet to again graph the depth over time. Companies will receive 10 points for graphing depth versus time. Successfully graphing the data is defined as showing the station judge a graph with time on the X-axis and depth on the Y-axis. Depth data should be graphed every 5 seconds. The depth should be measured from the bottom of the float. If the pressure sensor is not located at the bottom of the float, companies may use a conversion factor. Communicate to the station judge any conversion factor incorporated into your depth data. Companies should also communicate to the station judge how far below the waterline the pressure sensor is when on the surface. Station judges will compare the depths provided on the graph when the float is on the surface and on the bottom to known depths. Company's depths must be within 25 cm of the true depth to receive points for successfully graphing the data. Companies must only send defined data packets from their second vertical profile. Likewise, the depth versus time graph provided to the judge for the second vertical profile must only include data points from the second vertical profile. Depth from the first profile should not be included.

If the float fails to communicate to the mission station after its first or second vertical profile, it can continue to complete vertical profiles until it is successful. For example, if the float completes its first

vertical profile but fails to communicate to the mission station before descending for its second vertical profile, companies will receive points for a vertical profile, but would not receive points for communication. After completing a second vertical profile, if the float communicates successfully with the surface station, companies will receive points for their second vertical profile and would receive points for their first communication. If the float then completes a third vertical profile and successfully communicates to the mission station, companies will not receive any additional points for the third vertical profiles, but they would receive points for their second communication attempt.

The float must be less than 1 meter in overall height. The float may not have a diameter/length/width greater than 18 cm.

The float must move independently from the ROV. The float must operate independently; it may not be connected to the shore by a tether nor can the ROV interact with the float after successful deployment. All electrical power to the float MUST go through a single fuse. The float will operate as a non-ROV device (see 3.3.1 Non-ROV Device Power Specifications in the competition manual for additional rules on powering a non-ROV device).

Companies that do not design and construct a float can use data provided by the MATE ROV Competition to create a graph of depth versus time. Likewise, if a company's float does not transmit data back to the station receiver, companies may choose to use data provided by the MATE ROV Competition to create a graph of depth versus time. The data provided by MATE will be taken from a real-world GO-BGC float. Companies that design and construct a float may still earn points for deploying it and completing vertical profiles; creating a graph from MATE-provided float data replaces the communicating to the mission station and graphing portion of the tasks. Companies cannot receive points for graphing data communicated from their float AND graphing data provided by MATE.

Companies that do not design a float, or whose float is unable to transmit data back to the station, should inform the station judge that they are choosing to instead graph data provided by MATE. The judge will then provide a set of depth versus time data to the company. Once a company requests the MATE data, they can no longer receive points for communicating to the station or graphing data from their own float. Companies will receive 10 points for graphing depth versus time. Successfully graphing the data is defined as showing the station judge a graph with time on the X-axis and depth on the Y-axis. Companies must use a computer or device to graph the data; companies may not draw a graph by hand. Data points may be entered (or cut and pasted) to a device by hand.

Companies that choose to graph data provided by MATE will only receive points for creating ONE graph. They cannot earn points from creating two graphs from the same data.

Note for 2024!!!

At the World Championship, the RANGER product demonstration area may take place in water that is less than 2 meters deep. In order to accommodate float vertical profiles, **two additional company members will be allowed on the pool deck** to launch their vertical profiling float in the deep end of the pool and receive data from the float. These two company members can also help to carry equipment to the RANGER station, but will then move with the float to a designated station in the deep end during the

5-minute set up period. These two company members will be responsible for the entire *MATE Floats!* mission task, including deploying the float and receiving data. These two company members may deploy the float in the deep end, at the side of the pool, any time after the product demonstration time starts. Deploying the float from the deep-water station constitutes deploying the float in the designated area. These two company members are also responsible for receiving data from the float and creating the graph of depth versus time; they must bring the receiver and graphing material with them.

Two station judges will be located at the station dedicated to the *MATE Floats!* task, and companies will receive separate *MATE Floats!* scoring sheets in their company folder that they will need to bring them with them and to the *MATE Floats!* judges. While electricity (AC power) will be available at the *MATE Floats!* station, compressed air will not.

These two company members are solely responsible for the *MATE Floats!* task; they may not return to the product demonstration station to help with Task #1, Task #2, or Task #3. However, they may return to assist during the 5-minute demobilization period.

Company members from the 6-person product demonstration team are allowed to move to the deep-water station to assist in deploying, receiving, graphing, recovering, or working on the float if necessary. Those company members, as part of the 6-person team, may return to the product demonstration area to help with other tasks. Companies that do not have more than 6 members may designate up to two members from their 6-person team to move to the deep end and deploy their float. Those members of the 6-person team may return to the product demonstration area to help with the other tasks.

NOTE for 2024!!!

PRODUCT DEMONSTRATION RESPONSIBILITIES

Companies are responsible for designing, building, and bringing their own operational vertical profiling float. Companies must also design and bring any tools or devices to complete the required MATE product demonstration tasks.

Companies are permitted to create a basket to collect multiple product demonstration items. Any collection basket **MUST** be included in weight measurements. A collection basket is considered debris if still in the pool and not under control of the ROV when product demonstration time ends. Any collection basket must be deployed and returned by the ROV; it may not be pulled to the surface by hand or a surface device.

The MATE ROV Competition will provide all of the remaining product demonstration items.

PART 2: PRODUCT DEMONSTRATION PROP BUILDING INSTRUCTIONS & PHOTOS



The [Product Demonstration Prop Building Instructions & Photos](#) will be released with, but separate from, this competition manual.

PART 3: VEHICLE DESIGN & BUILDING SPECIFICATIONS



1.0 GENERAL

Questions about production demonstrations and design and building specifications should be sent to the [Competition Technical Manager](#). Question, answers, and official rulings will be posted on the [MATE ROV Competition Q&A and Official Ruling Document](#). This ensures that all companies can view the questions and answers and helps to avoid duplicate questions. That said, please make sure that your question(s) has not already been asked – and answered – before emailing. When emailing their question, companies should reference:

- Any specific specification or rule (e.g. ELEC-002R)
- Competition class

Conventions: All values contained in this document are threshold values unless specifically stated otherwise. All water depths are given in meters (m). All dimensions and measurements utilize SI units.

[Your regional coordinator or your regional contest's website](#), will inform you of any specific requirements or changes for your regional.

2.0 SAFETY

Safety is the competition's primary concern and guiding principle. Any system that is deemed unsafe by competition officials will not be permitted to compete. If a safety concern is identified during the initial inspection, companies are permitted to modify their system and have it re-inspected. Companies are permitted to have their vehicle re-inspected twice. If a company fails to pass its third and final safety

inspection, it is disqualified from the underwater competition portion of the event. There are NO APPEALS once an ROV has been disqualified.

NOTE for 2024!!!

MATE ROV Competition safety inspectors will be reinforcing the competition's emphasis on safety. Wiring discipline/workmanship (ELEC-023R) and strain relief at both ends of the tether (ELEC-024R) will be areas of particular emphasis. **Companies that do not meet these safety standards will not be permitted to compete in the in-water events.** Additional examples of wiring workmanship will be included in the [MATE ROV Competition Safety Inspection Tutorial](#). See the [Tech Bulletin – MATE Expected Work Practices](#) for additional information.

Examples of safety violations from previous ROV competitions include:

- Companies used equipment that did not participate in and/or the pass safety inspection
- The electrical SID included in the technical documentation did not show a main fuse.
- The ROV used pneumatics, but the technical documentation did not include a pneumatics diagram or pneumatic specifications.
- The ROV used pneumatics, but the company had not passed the fluid power quiz.
- Circuit boards and components were not securely fastened.

2.1 Job Site Safety Analysis

Each member of the company is encouraged to read [Oceaneering Americas Region HSE Employee Handbook](#), with emphasis placed on the following chapters.

Chapter 1 - Housekeeping

Chapter 9 - Hand Safety

Chapter 11 - Lifting and back safety

Chapter 12 - PPE

Chapter 17 - Tool Safety

Chapter 24 - Electrical Safety

Chapter 29 - Employee Observation Program

Chapter 33 - JSEA

Chapter 37 - Working at Other sights

Job Site Safety Analysis (JSAs)

For companies advancing to the World Championship, 10 points can be earned by creating a JSA and submitting it along with (but as a separate document from) the [Technical Documentation](#).

A **JSA** describes job tasks in step-by-step fashion, identifies associated hazards at each step, and outlines proper hazard controls that minimize the risk of injury or illness to the individual(s) performing that task. JSAs are used extensively by the offshore industry.

For more information and examples, companies can visit the following web sites:

- <http://ehs.berkeley.edu/how-do-i-write-and-update-job-safety-analysis-jsa>

- https://www.safetyworksmaine.gov/safe_workplace/safety_management/hazard_analysis.shtm

POTENTIAL HAZARDS

DESCRIBE JOB STEP <small>(List the natural steps of the job. Do not make the steps too broad or too fine)</small>	POTENTIAL HAZARDS <small>(What are the potential hazards identified at this part of the job steps)</small>	RECOMMEND RISK CONTROL MEASURES <small>(describe how the identified hazards can be eliminated or reduced)</small>	RESPONSIBLE PERSON (S) <small>(Implementing control)</small>	INITIAL <small>(Of the responsible person/s)</small>
Toolbox Talk	Miscommunication	<p>ANYONE can call ALL STOP at any point if an unsafe condition /act is perceived/observed.</p> <p>Cell phone use is PROHIBITED in test area while testing!</p> <p>Ensure all participants are aware of procedures and roles within the procedure and sign JSEA acknowledging thusly.</p> <p>Ensure that all participants are wearing correct PPE (safety glasses, safety shoes, gloves, and hard hats if crane ops are being performed)</p> <p>Ensure participants/witnesses are wearing adequate clothing for weather conditions and to take breaks whenever necessary.</p>		
Hydraulic Function Testing	<p>Stored/Trapped Energy: Up to 12,000 PSI</p> <p>Environmental Discharge</p> <p>Tubing/Hose Failure</p> <p>Line of Fire</p>	<p>Ensure all functions have pressure/flow reduced to 0 PSI when not being actively function tested.</p> <p>Ensure each circuit is setup correctly before increasing pressure.</p> <p>Ensure Vent hoses are properly connected to fluid containment reservoir.</p> <p>Ensure all hoses are whip checked before coming up on pressure.</p> <p>Ensure valves and actuators are in proper configuration before testing.</p> <p>Ensure relief valves are set to relieve at the proper setting.</p>		

Example JSA task items courtesy of Oceaneering International

NOTE for 2024!!!

Companies should focus their JSA on their deck/dive operations only. **Shop safety and tool safety for building the ROV is extremely important but does not belong in this JSA.** The submitted JSA should focus information on potential hazards and recommended risk control measures of a company’s pool side operations. This JSA should cover topics such as:

Deck Ops/Launch and Recovery:

- Entering/exiting the pool deck area
- System set up
- Power up checks
- Pool side operations
- System breakdown

Examples of JSAs:

- [2023 University of Washington – EXPLORER](#)
- [2023 St. Francis Catholic High School – RANGER](#)

2.2 Safety Pre-Inspection

For companies advancing to the MATE World Championship, a safety pre-inspection will be completed before competition day. Companies will submit documentation to their regional coordinator. Safety pre-inspection document submissions will include the following:

- Technical documentation
- Company spec sheet
- SID [Electrical, Pneumatic & Hydraulic as utilized]
- Non-ROV device design document (if used)
- Non-ROV device SID (if used)
- Company safety review

See 2.2.1 Safety documentation requirements below for more information.

Regional competitions may not require an initial safety inspection or may not require all of these documents. Contact [your regional coordinator or visit your regional contest's website](#) to determine the required documents as well as the date and proper format for submission.

NOTE for 2024!!!

Do not submit your regional documentation to MATE World Championship ROV Competition officials. **Regional submissions sent to the MATE ROV Competition management team or to World Championship officials are NOT guaranteed to be forwarded to the regional coordinator.** Only companies advancing to the World Championship should submit documentation to the MATE World Championship ROV Competition officials.

Once received, safety inspectors will conduct an **initial safety and documentation review** to identify potential safety violations. This review will be worth 20 points. Companies with violations will be notified via e-mail. Once notified, companies must:

- a. Respond acknowledging receipt.
- b. Layout a plan to address the violation.
- c. Submit new documentation if required.

Safety inspectors will also compile a list of the safety violations and publish them to the competition website. This is not done to “call out” or embarrass companies in any way. It is to emphasize the fact that EVERYONE is responsible and accountable for ensuring a safe, successful event. It also allows the company to correct the safety violations before arriving at the competition. This list will be published in each competition class [Scoring](#) page.

While your regional's safety inspectors will review your documentation for safety, they may or may not award points. Contact [your regional coordinator or visit your regional contest's website](#) for more information.

2.2.1 Safety documentation requirements

Unless stated otherwise, each document **MUST** be submitted separately. In addition to the SID included in the technical documentation, an individual SID must be submitted for the initial safety inspection. The company safety review should **NOT** refer to systems shown in a submission video or detailed in the technical documentation.

DOC-001: SID Electrical: This must be an electrical diagram for all ROV systems. One section should focus on the systems above the waterline, and one section should focus on systems on the ROV (below the waterline). The SID:

- Should not exceed one 8.5" x 11" page in length (both above and below water sections, as well as any other information, should be on one page). Printed documents must be sized to fit on one side of the printed paper.
- Must be drawn with a CAD (computer assisted drawing) program. Hand drawn figures are not permitted.
- All symbols used should be standard symbols as specified by ANSI, NEMA or IEC.
- The SID must include a FUSE SYMBOL using an ANSI, NEMA or IEC symbol.
- The SID must not be component level schematics, but a higher-level interconnection block type diagram. Do not include individual pins on a board; the SID is a higher-level diagram.
- Fuse calculations must be included on the SID.

The following ANSI and IEC fuse symbols are all acceptable for MATE documentation.

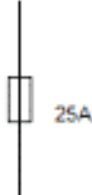
Item	ANSI	IEC
FUSE		

An example of an acceptable SID can be found here:

- RANGER example: [2018 RANGER Macau Anglican SID](#)

DOC-002: SID Fluid Power: Companies using fluid power **MUST** include a fluid power diagram using industry standard symbols, showing all items, regulators, and control valves. The diagram must document the components on the surface and the components located onboard the ROV. Fluid power diagrams must use ANSI, NEMA or IEC symbols. The fluid power diagram must also be drawn with a CAD program and should be a one 8.5" x 11" page diagram. The fluid power diagram may be included on the main electrical SID or as a separate one-page document.

DOC-003: SID Non-ROV Device: Companies utilizing an independent sensor or other electrically powered, non-ROV device to complete a product demonstration task must submit a SID for this device.

The *MATE Floats!* vertical profiling float, if designed and used at the competition, is considered a non-ROV device. This diagram must be completed to the specifications listed in DOC-001. The non-ROV device SID may be included on the main electrical SID or as a separate one 8.5" x 11" page document. Two (or more) separate pages may be used for two (or more) different non-ROV devices. Companies must include fuse calculations on their non-ROV device SID. Companies not designing and building a vertical profiling float or powered release container should state so in their Company Safety Review.

DOC-004: Non-ROV device design: Companies will be required to submit a one page written and photographic description of their non-ROV device. This document must contain a photo or diagram of your non-ROV device. This document **MUST** include the type of battery used.

NOTE for 2024!!!

Any electrical or fluid powered device on the ROV **MUST** be documented on a SID. Depending on the type of device, it may be on the main ROV SID, an independent sensor SID, a Non-ROV device SID, or a Fluid SID. Any such device not represented on a SID cannot be used in the competition.

DOC-005: Company safety review: RANGER companies submitting a company safety review **MUST** show compliance with the following specifications:

- Anderson Powerpole connectors are the main point of connection to the MATE supply (ELEC-010R).
- A properly sized fuse is within 30 cm of the main point of connection to 12-volt power. The company must use a ruler to show this distance (ELEC-008R).
- Fuse calculations (ELEC-008R).
- The inside of the control box does not have exposed wiring (ELEC-017R), the control box is neatly laid out with attention to workmanship (ELEC-022R), a separation and identification of 120VAC wiring from DC and control voltages (ELEC-023R). If AC wiring is not used in the control box, include a statement saying no AC is used. Note: Companies using a computer or laptop should state that they are using a laptop and include the type of controller used (Joystick, Xbox controller, etc.).
- The tether leading to the control system has adequate strain relief (ELEC-024).
- The tether leading to the ROV has adequate strain relief (ELEC-024).
- If hydraulics / pneumatics are used that the company has passed the Fluid Power Quiz (FLUID-014). **If fluid power is not used on the vehicle, include a statement saying no fluid power is used.**
- Companies using only manually powered pumps should include information about the system.
- If used, hydraulic / pneumatic systems include a pressure release valve and regulator in the system (FLUID-007, FLUID-011), and that any pressurized cylinder, pressure storage device meets the MATE specifications (FLUID-012, FLUID-013).
- **NOTE FOR 2024!!!** If used, the specifications and details of the hydraulic / pneumatic components used, including pressure ratings of hoses and components.
- Any watertight housing on the vehicle can withstand pressure at 4 meters (MECH-001).

- All propellers are shrouded and have propeller guards (MECH-006).
- The ROV has no sharp edges or elements of the ROV that could cause damage (MECH-006, ELEC-017R).

The following photographs **MUST** be included within the company safety review:

- Anderson Powerpole connector within 30 cm of fuse (show fuse, ruler, and connectors)
- Inside of the control box with wires labeled or control system (and controller) for those using a computer or laptop
- Strain relief where the tether connects to the control system
- Strain relief where the tether connects to ROV
- Compressor or pump (if pneumatics/hydraulics are used) including release valve and regulator
- Propeller shrouds (front and back of one propeller)

The company safety review should include an explanation of how each system meets the safety specifications and include photographs of the relevant systems for review by the MATE ROV Competition officials.

Examples of RANGER Company Safety Reviews:

- [St. Francis Geneseas Company Safety Review 2023](#)
This company includes all components in their company safety review.
- [Oostburg High School Company Safety Review 2023](#)
This company does not use fluid power or a non-ROV device, and clearly state that fact in the company safety review.

Initial Safety and Documentation Review points

Penalty points will be deducted from the initial safety and documentation review if:

- Companies do NOT submit ALL the required documentation by the given deadlines. See [6.2 KEY DEADLINES](#).
- The SID does not show a fuse, or the fuse does not use an ANSI, NEMA or IEC symbol.
- Fuse calculations are not shown on the SID.
- The vehicle uses fluid power, but a fluid power diagram is not included.
- A non-ROV device is used but is not shown on any SID.
- Companies not using fluid power, or not attempting a task requiring a non-ROV device, should state this in the company safety review.
- The technical documentation is over 8MB in size.
- Other documents are over 2MB in size.
- The company safety review does not show compliance with all of the specifications.

The initial safety and documentation review rubric can be found [here](#).

2.3 Onsite Safety Inspection

Companies must complete their onsite safety inspection before their vehicle enters the water.

Companies advancing to the World Championship must complete their initial on-site safety inspection immediately after checking in. A sign-up form with specific dates and time frames will be circulated in advance of the World Championship. Companies should review this form carefully and select the date and time frame that aligns with their travel plans. Companies that ship their ROV should also consider the expected delivery date and time when making their selection; without a vehicle present, the company will fail their initial safety inspection. Accommodations will be made for companies that experience travel delays beyond their control (i.e., a cancelled flight or flight delay), but these will be the exceptions and not the norm.

Companies are required to check in and undergo their first safety inspection prior to the opening ceremonies.

At the World Championship, companies MUST pass their safety inspection by the end of the first day of the competition. Companies that do not pass their safety inspection by the end of the first day will be disqualified from the underwater product demonstration component.

Note for 2024!!! A power supply will be available; companies will power up their control system and vehicle during the safety inspection. The inspector(s) will reference the list of violations as he/she conducts the safety inspection of the vehicle using the safety inspection rubric.

What follows is the safety inspection protocol used at the World Championship. Consult [your regional coordinator or visit your regional contest's website](#) for more information about the safety inspection process used at your regional.

2.4 Safety inspection protocol

1. Before entering the water for practice or a product demonstration run, the ROV system must go through a safety inspection. Once a company successfully passes inspection, they will turn in their safety inspection sheet to the safety inspector and receive a Blue PASSED Card with their company number on it. Companies must present the Blue PASSED Card to the pool practice/product demonstration coordinator before their vehicles are permitted to enter the water.
2. Competition staff will conduct a safety inspection of the vehicle using the [safety inspection rubric](#).
3. If the safety inspector(s) identify a safety violation, companies will have the opportunity to address it. The pool practice or product demonstration run schedule will NOT change to allow companies more time.
4. If during the second safety review the
 - a. violation has not been properly addressed or
 - b. another violation is revealedcompanies will have ONE additional opportunity to address the issue.
5. If during the third safety inspection a violation still exists, safety inspectors will request that the Chief Judge(s) review the violation. If the Chief Judge(s) confirms the violation, companies will not be permitted to participate in the underwater product demonstration component of the

competition. However, companies can still participate in the engineering and communication (technical documentation, engineering presentation, and marketing display) component.

6. Reminder: All companies must present the Blue PASSED Card to the pool practice or product demonstration judge before placing their vehicles in the water. In addition, product demonstration station judges and competition officials can pause or stop a product demonstration run at any time if they feel that there is a potential safety concern.

NOTE for 2024!!!

All items used on the ROV MUST participate in and pass safety inspection. Companies that use a device that did not participate in and pass the safety inspection will be disqualified.

2.5 Safety Inspection Points

The safety inspection is worth 30 points. Each time a company fails its safety inspection it loses 10 points. After a company fails its second inspection, it must meet with the chief safety inspector to discuss a plan of action prior to returning to its workstation. THREE STRIKES and a company

- a. Receives 0 points for the safety inspections and
- b. Is disqualified from the underwater product demonstration component

3.0 SPECIFICATIONS

The ROV system must meet the following requirements:

3.1 Operational

3.1.1 Multiple Vehicles

OPER-001: RANGER class companies are required to design and build ONE ROV that can complete the necessary product demonstration tasks. "Floating eyeballs" or other vehicles that are not hard connected to the frame of the main vehicle are NOT permitted. Cameras designed to provide a "birds-eye view" are permitted provided that these cameras are hard connected to the frame of the main vehicle. "Hard connection" does not include the wiring between the camera and the ROV.

3.1.2 Environmental

OPER-002: The ROV system must be able to function in fresh, chlorinated water with temperatures between 15 °C and 30 °C. The water should be considered conductive of electrical currents.

OPER-003: The pool will not be covered or purposefully darkened in any way, although the specific product demonstration tasks may require that your ROV operates in low-light.

OPER-004: Depending on the venue, pressurized pool filtration system outlets may cause unexpected currents.

OPER-005: The pool venue at the World Championship has a smooth bottom.

Note: Regional competitions may be held in pool venues with different environmental conditions than those listed here. If you are unfamiliar with the regional pool, contact [your regional coordinator or visit your regional contest's website](#) for additional information.

3.1.3 Service Requirement

OPER-006: Companies shall provide a crew of at least 3 but not more than 6 people on the pool deck to operate the ROV System. Two additional company members are allowed to launch, operate, and recover the vertical profiling float. Companies can send a larger crew to the event, but no more than six plus the two additional members can be on the deck at any time. More information about this “product demonstration team” is provided in the [COMPETITION RULES](#).

3.1.4 Maintenance and Calibration Requirement

OPER-007: System maintenance during field operations shall be conducted by ROV personnel at their workstations. Work of any kind must not be done by company mentors or advisors. All maintenance parts and equipment necessary to meet the operation requirements shall be provided by the company. More information about these regulations is provided in the [COMPETITION RULES](#).

OPER-008: All measurement devices shall be calibrated according to manufacturer recommended calibration procedures and performed by company members only. Company mentors or advisors are not permitted to perform calibration procedures. More information about mentor restrictions is provided in the [COMPETITION RULES](#).

3.2 Mechanical/Physical

This section of the document provides specifications for the mechanical properties of the ROV system.

3.2.1 Materials

MECH-001: Any components or electronics housings on the ROV shall be capable of operating to depths of 4 meters.

3.2.2 Size and Weight

MECH-002: ROVs are limited to a maximum weight, in air, of 25 kg. Vehicles over this weight will not be allowed to compete. Product demonstration tasks will limit the size of the vehicle. Companies must be able to personally transport the vehicle and associated equipment to the product demonstration station and to the engineering presentation room. ROV systems must be capable of being safely hand launched. Additional points will be given to lighter vehicles. (See [WEIGHT RESTRICTIONS](#).)

3.2.3 Tether Length

MECH-003R: At the World Championship, ROVs must be capable of operating in a maximum pool depth of 4 meters (14 feet). All underwater product demonstrations will take place within 10 meters from the side of the pool. The product demonstration station will be no more than 3 meters from the

side of the pool. Tether length should be calculated accordingly. Regional competitions may be held in pool venues with different maximum depths than those listed here. If you are unfamiliar with the regional pool, contact [your regional coordinator or visit your regional contest's website](#).

3.2.4 Vehicle Deployment and Recovery

MECH-004: The ROV system must be launched and recovered manually; no powered winches or portable cranes can be used. Hand-powered lifts and levers may be used to launch and recover the vehicle. The vehicle and any associated equipment must not damage any part of the pool or pool deck.

MECH-005: Any hand-powered lift or levers that are used as a LARS must be detailed in the technical documentation and must be part of the safety inspection procedure. Any LARS equipment that is deemed as unsafe at the safety inspection will not be allowed. Ladders, tripods, or other bracing equipment are not permitted as part of a LARS.

3.2.5 Propellers

MECH-006: Propellers must be shrouded and have thruster guards. ROVs that have propellers exposed without thruster guards will not pass the safety inspection and will not be allowed to compete. A shroud must completely encircle the propeller and extend at least 2 mm in front of and behind the propeller. Thruster guards must completely cover any openings on the thruster and should have a mesh size that meets [IP-20 standards](#) (solid particulate protection level 2). **This IP code equates to a mesh size <12.5 mm.** To pass safety inspection, the shroud and propeller guard should meet this standard. If your finger can touch the propeller, then it is not properly guarded.

Teams may construct thruster guards, 3D print thruster guards, or may purchase commercially available thruster guards. All motors on the ROV must be protected with shrouds and thruster guards on all sides.

See <https://www.thingiverse.com/thing:1498338> for an example of an acceptable thruster guard.

3.3 Electrical

ELEC-001: All power provided to the ROV system through an external connection for any purpose during the competition must be obtained from the MATE competition power supply. This includes dedicated lines for cameras, manipulators, and any other devices. This is a singular point of connection; all power to the ROV must pass through the MATE-provided fuse AND the single in-line fuse as specified in this section.

NOTE for 2024!!!

Circuit breakers will not be allowed on the ROV system. Companies must use an inline fuse(s).

ELEC-002R: The ROV system must be capable of operating off the power provided by a MATE supply with a nominal voltage of 12 VDC. This voltage may be as high as 14.8 volts. At the World Championship, power for the RANGER class will be provided by isolated power supplies. At regional competitions, power may be provided by isolated power supplies or batteries. [Contact your regional](#)

[coordinator or visit your regional contest's web site](#) if you have questions about the type of power source being used. Your system should be designed to work with the maximum specified voltage of 14.8 VDC.

ELEC-003R: The ROV system may deliver any voltage to the ROV at or below the nominal supply voltage provided. Conversion of this voltage is allowed prior to it arriving at the ROV.

ELEC-004R: ROV systems may use any voltage desired up to 12 volts.

ELEC-005R: Voltage may not be increased above the nominal 12 volts anywhere in the ROV system.

ELEC-006R: Sonar or other systems that may have DC/DC conversion resulting in voltages above 12 V nominal are not permitted.

ELEC-007R: Voltages in excess of the class parameters set forth in this specification are not allowed on the ROV system at any time other than any inductive spikes that are caused by the switching on/off of motors, solenoids and other inductive devices. Companies should design their systems to handle these voltage spikes but will not be penalized for the presence of these in a system. For additional information on this, companies can research back electromotive forces (back EMF), collapsing magnetic motor fields, and transient suppression.

3.3.1 Non-ROV Device Power Specifications

NEW for 2024!!!

Systems that qualify as a non-ROV device in 2024:

- Vertical profiling float

No other devices qualify as non-ROV devices.

ELEC-NRD-001: The vertical profiling float cannot be powered from the surface. If the float is powered, it must use onboard batteries. Voltage is limited to 12 VDC maximum; amperage is limited to 6 amps maximum. All power for the non-ROV device must go through a single fuse (see ELEC-NRD-005).

ELEC-NRD-002: The vertical profiling float non-ROV device may utilize thrusters but may not include any cameras. Vertical profiling floats cannot use a camera onboard to take images or video of pressure data and transmit those images/videos to the surface station.

ELEC-NRD-003: Companies may not power the vertical profiling float non-ROV device from the surface.

ELEC-NRD-004: Onboard power is allowed for non-ROV devices. If onboard batteries are being used, the following specifications must be met:

- Batteries must be primary (non-rechargeable).

- AAA, AA, A, A23, C, D or 9V alkaline batteries are allowed. No other size or chemical composition is allowed. 12-volt, outdoor, rechargeable batteries are **NOT** allowed. High discharge LiPo batteries are **NOT** allowed.
- Batteries are mounted in a manner that they are not loose inside the container.

ELEC-NRD-005: Battery fusing for non-ROV devices is an important consideration and the following rules must be adhered to.

- A single fuse must be utilized that will shut down all power sources in the non-ROV device if the fuse blows.
- A fuse (7.5 amps max) must be installed within 5 cm of the battery positive terminal.
- All fuses, when installed, must be able to be visibly inspected for amperage through a clear housing or immediately after an opaque NRD device housing is removed without the need to uncover the fuse.
- ATO type blade fuses or MINI blade fuses **MUST** be used for any fusing. These fuses provide easy visual inspection for amperage using industry standard color codes.

Fuse Reference: [ATO fuse](#) [MINI fuse](#)

These fuses are all rated for 32VDC and are color coded for amperage.

- All blade fuses **MUST** correspond to the standardized color codes listed on the fuse links above.
- For systems with multiple battery packs, the battery packs should be connected on the negative terminals with the fuse (7.5 amps max) located off of the common negative terminal connection. Each individual battery pack should also be fused with fuses no more than 7.5A each.

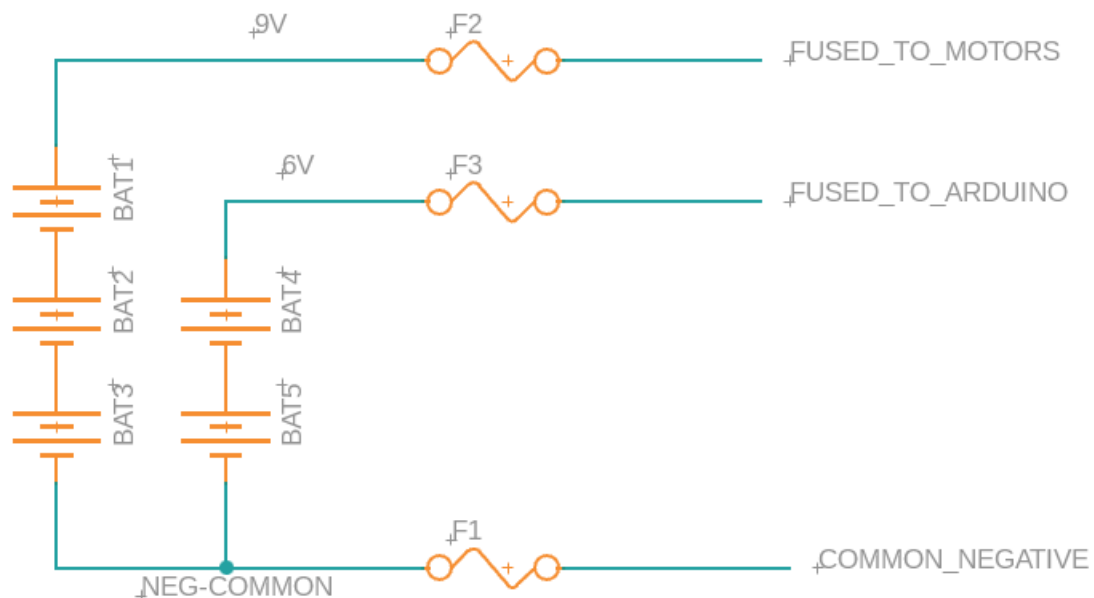

- The maximum distance from a battery pack to any fuse is 5 cm.

ELEC-NRD-006: The enclosure housing must be designed so that it will open if the pressure inside the housing is greater than the outside pressure.

There are two allowable methods for pressure relief:

1. A pressure relief hole of a minimum of at least 2.5 cm in diameter. This hole can be plugged up with a rubber plug but must be friction fit. Threads or other fastening methods are not allowed. Holes less than 2.5 cm in diameter will not pass safety inspection.
2. The enclosure is built in a manner that an end cap will pop off if under pressure. This can be an internal or external cap with O-rings to provide sealing. The sealing diameter of the end cap must be 2.5 cm in diameter or greater (this limits the smallest ID of an enclosure to 2.5 cm).

Additional notes:

- Under no condition should the housing be built with fasteners to hold the housing together. There must be at least one 2.5 cm or larger opening that serves as a pressure release.
- Utilization of pressure release valves are not acceptable as they cannot be tested at the competition site.

ELEC-NRD-007: A SID must be submitted for any non-ROV device that uses electrical power.

3.3.2 Independent Sensors

Certain product demonstration tasks may require a sensor that is independent of the vehicle. These electrically powered sensors will operate under the following independent sensor rules.

ELEC-IS-001: Independent sensors must be powered from the surface; no onboard batteries are allowed.

ELEC-IS-002: Companies may use USB to connect their sensor to a computer. Companies may also use surface battery packs (limited to 12 volts maximum) or the MATE supply to provide power for their independent sensor.

ELEC-IS-003: The independent sensor may only contain the intended sensor; thrusters, cameras, or other systems MAY NOT be attached.

ELEC-IS-004: Companies that use an independent sensor must provide a 3 amp (or less) fast blow fuse on the positive side of their connection. If companies are using the 12-volt MATE supply to power their sensor, both the ROV and the sensor must run through the single fuse before splitting off to the 3-amp sensor fuse. Companies using USB only to power an independent sensor may utilize the built-in current limiting of USB and do not need to add an additional fuse.

ELEC-IS-005: An SID must be submitted for any independent sensor that uses electrical power.

3.3.3 Current

ELEC-008R: ROVs will be limited to 25 amps.

NEW for 2024!!!

Companies MUST use ATO type blade fuses or MINI blade fuses. These fuses provide easy visual inspection for amperage using industry standard color codes.

Fuse Reference: [ATO fuse](#) [MINI fuse](#)

These fuses are all rated for 32VDC and are color coded for amperage. All blade fuses MUST correspond to the standardized color codes listed on the fuse links above.

COMPANIES WITHOUT A PROPER BLADE FUSE WILL NOT PASS SAFETY INSPECTION!

The ROV system must have a fuse that is calculated based upon the maximum current draw of the ROV. This overcurrent protection must be calculated as follows: ROV Overcurrent Protection = ROV Full Load Current * 150%. The overcurrent protection value may be rounded up to the next standard fuse. The ROV Overcurrent Protection value may exceed 25 amps, but companies are limited to a 25-amp fuse. Companies must use the fuse that is rated for their overcurrent protection. Companies that use a fuse larger than their calculated value will not pass safety inspection. Companies may use a fuse smaller than their calculated value without penalty. The fuse must be installed in the positive power supply line within 30 cm of the power supply attachment point. The fuse may be a slow blow type. The SID and other electrical diagrams must show the fuse and include the amperage of the overcurrent protection. In addition, the SID must show the calculations used in determining the overcurrent protection value. SIDs without these calculations shown will have points deducted from the initial safety inspection and documentation review. Also, SIDs without fuse calculations will not pass safety inspection. The motor current used must be full load current while in water, not while operating in air. Overcurrent calculations using the lower current values will be rejected.

ROV overcurrent protection example 1:

- Four motors, 2.7 amps each = 10.8 amps
- Two cameras = 0.25 amps
- Two servo motors = 0.8 amps
- One laser = 0.02 amps
- Total Amps: 11.87 amps X 150% = 17.8 amps
- ROV uses a 20-amp fuse

ROV overcurrent protection example 2:

- Six motors, 3.7 amps each = 22.2 amps
- Two cameras = 0.85 amps
- Two servo motors = 0.8 amps
- One laser = 0.02 amps
- Total Amps: 23.87 amps X 150% = 35.8 amps
- ROV uses a 25-amp fuse

All information on overcurrent protection should be included on the SID. Show your work.

The MATE power supply will be protected by a 25-amp fuse; however, the ROV system must also have its own calculated fuse.

ELEC-009R: ROV systems are allowed one replacement fuse during the product demonstration. In the event that the ROV system blows the second fuse during the demonstration, time will stop, the demonstration run will be over, and no additional points will be earned. Companies should have adequate replacement fuses on hand, MATE will not provide replacements. Standard sizes for fuses are 15, 20, and 25 amps. Additional standard fuse sizes are 1, 3, 7.5, and 10 amps.

3.3.4 Power Connections

ELEC-010R: Power supply connections will be red/black Anderson Powerpole Connectors. Companies' ROV system power wires must have proper connectors to obtain power. The Anderson Powerpole Connectors must be connected to the ROV power wires securely; use of a proper mechanical crimper is required. Hand crimp tools do not have the force necessary to ensure proper and safe connections. MATE will not provide companies with connectors or adapters at the 2024 World Championship.

NOTE for 2024!!!

The red and black pole pieces must be attached. Loose Powerpoles (those not attached) will not pass safety inspection.

<https://www.andersonpower.com/shop/powerpoler-15-45-one-row-1x2-assembly-bonded-kr.html>

These are two-piece connectors as shown in the picture below.



ELEC-011R: The power supply may be located up to 1 meter from the station table and may be located on either side of the table. MATE recommends a power cable long enough to reach the power supply up to 3 meters from your control system.

3.3.5 Tether Voltages

The signals in the tether must meet the following specifications:

ELEC-012R: DC main supply at a nominal voltage of 12 VDC as provided by the MATE power supply.

ELEC-013R: Low voltage, low current AC or DC control or sensor signals. Low voltage is defined as a voltage equal to or less than the maximum supply voltage per class specification. Low current is defined as being less than 500 mA. Examples include video signals, control signals for electrically powered manipulators, sensor signals, etc.

Note: Companies concerned about how voltage loss will affect their camera(s) should consider adding a separate line in the tether to supply the camera from the main power source. This dedicated line for cameras is permitted, provided it runs through the single fuse.

ELEC-014R: Ethernet, USB, or other ANSI or IEC accepted serial protocol signals.

NOTE for 2024!!!

All cameras, including USB cameras, must be powered by the MATE supply. Powering a USB camera from the MATE supply can be accomplished by using a USB repeater / extender that has a separate power input at the far (ROV) end. The ROV would then provide the power to the device from the MATE supply. USB cameras directly plugged into laptops or surface computers are not allowed. Be sure to denote camera power on your SID.

ELEC-015R: NTSC or PAL Video signals

ELEC-016R: Fiber optic cabling of any type may be used.

3.3.6 Exposed Connections and Disposable Motors

ELEC-017R: ROVs with electrical connections that are exposed to water and not sealed are not permitted to enter the water. Taping a connection with electrical tape only does not constitute a sealed connection. The process of sealing electrical connections must include methodologies such as, but not limited to, Silicone RTV, hot melt glue, epoxy, self-vulcanizing tape, and enclosure of the connections in a housing.

ELEC-018R: “Disposable motors” are not permitted; these are exposed motors with no waterproofing.

Brushless motors must be properly waterproofed. Companies must either provide manufacturer documentation showing their brushless motors are waterproof or must properly waterproof their motors and provide documentation showing their methodology. Non-sealed brushless motors will not pass the safety inspection.

See the [MATE Technical Bulletin](#) for proper methods to waterproof a brushless motor.

3.4 Onboard Electrical Power

ELEC-019R: Onboard electrical power (i.e., power not provided by the tether): Onboard battery power is not allowed on the primary ROV. See the [3.3.1 Non-ROV Device Power Specifications](#) regarding onboard power.

NOTE: Water leaking into a closed battery container can result in the generation of hydrogen gas. This gas can build up inside a pressure housing and create an unsafe situation. Any battery housing must be designed to open if the pressure inside the housing is greater than the outside pressure to meet the MATE safety standards. See the non-ROV device onboard battery rules (ELEC- NRD-004) for more information.

3.5 Power Shutdown

ELEC-020R: For safety purposes, any ROV system that is disconnected from the surface supply must stop functioning in less than 5 seconds. This applies to electrical, pneumatic, and hydraulic power sources. Any filters, capacitors or accumulators must be sized accordingly to meet this specification.

3.6 Fluid Power

Any vehicle using fluid power must provide a fluid power diagram. Fluid power is defined as hydraulic pumps (water) or pneumatic pumps (air) on the vehicle or on the surface.

3.6.1 Hydraulic Power

FLUID-002: Hydraulic fluid: Water or biodegradable food-grade fluid, only.

FLUID-003: If a biodegradable food-grade fluid is used, a Material Safety Data Sheet (MSDS) must be provided at the safety inspection. The MSDS must show the type of fluid used and its compatibility with the Biodegradable Food-Grade specification. Companies using water do not need to provide an MSDS.

FLUID-004: The following fluids are approved for use in hydraulic systems:

- a. Water
- b. Biodegradable Food-Grade Hydraulic Oil ISO Grade 32/46, SAE Grade 20, McMaster-Carr part# 3499K22

All other bio-degradable food-grade fluids must be approved by the [Competition Technical Manager](#) by May 15, 2024. Companies with regional competitions prior to May 15, 2024 must have their bio-degradable food-grade fluids approved two weeks prior to their regional event.

FLUID-005: Maximum Hydraulic pressure allowed: 10.33 bars (150 psig).

NOTE for 2024!!!

FLUID-006: Hydraulic system: All lines, fittings, and hydraulic devices must be rated for a minimum pressure of two (2) times the maximum supply pressure. Hydraulic component specifications **MUST** be included in the Company Safety Review.

FLUID-007: Hydraulic pumps must be part of the safety inspection.

1. They must have a pressure relief valve with a maximum setting of 300 psig or less installed before the pressure regulator.
2. The pump must have a regulator in place and set to 150 psig or less.
3. Pumps with any sign of external rust or deterioration will not be accepted.
5. All wiring must be secure.
6. All guards must be in place.
7. Hydraulic pumps may run off of the 15 A 115 VAC outlet provided for command and control as long as the hydraulic fluid is not used to propel the ROV. The hydraulic fluid is to be used for grippers and actuators only.

Companies using hand/manually powered hydraulic systems do not need a pressure relief valve or regulator in the system. The hand/manually powered hydraulic system must be included on a SID.

3.6.2 Pneumatic Power

FLUID-008: Pneumatic fluid: Compressed air or inert gas only

FLUID-009: Maximum pressure allowed: 2.75 bars (40 psig)

NOTE for 2024!!!

FLUID-010: Pneumatic system: All lines, fittings, and pneumatic devices must be rated for a minimum pressure of two and a half (2.5) times the maximum supply pressure. For example, if an 83 bar (1200 psig) tank is regulated to 2 bars (30 psig), then all system components must have a minimum rating of 5.17 bars (75 psig). Pneumatic component specifications **MUST** be included in the Company Safety Review. **Note: Aquarium tubing is not generally rated for the pressures associated with compressed gas systems and should not be used in a pressurized pneumatic system.**

FLUID-011: Air compressors must be part of the safety inspection.

1. They must have a pressure relief valve installed before the pressure regulator.
2. The compressor must have a regulator in place and set to 40 psig or less.
3. Compressors with any sign of external rust will not be accepted.
4. The tank drain valve must open.
5. If more than 5 ml of water exits upon opening the drain valve, the compressor will not be accepted.
6. All wiring must be secure.
7. All guards must be in place.
8. Air compressors may run off of the 15 A 115 VAC outlet provided for command and control as long as the air is not used for motor thrust. The air is to be used for buoyancy/ballast, grippers and actuators only.

Companies using manually powered pneumatic systems do not need a pressure relief valve or regulator in the system. The manually powered pneumatic system must be included on a SID.

For RANGER class companies advancing to the World Championship, the MATE ROV Competition will provide compressed air at each station. Companies using compressed air MUST attach to the provided compressed air; companies may not use their own compressor. See [3.9 MATE Provided Equipment](#) for more information.

[3.6.3 Pressurized Cylinders](#)

FLUID-012: Pressurized cylinders may be used, but must remain above the water surface and meet the following specifications:

- a. Approved by US DOT (Department of Transportation) or TC (Transport Canada). For regional competitions taking place outside of the US, check with your [regional coordinator](#) for approval.
- b. Have a current official inspection/test sticker and/or stamp.
- c. Stamped with the maximum allowable pressure.
- d. Contain a pressure relief safety device.
- e. May be filled up to the maximum allowable pressure of the cylinder.
- f. Must be regulated at its output to a maximum of 2.75 bar (40 psig).
- g. Must have an easily accessible shut-off valve that is clearly marked with instructions.
- h. May only be stationed on the surface, not on the ROV.
- i. Must be secured in a safe manner such that they will not fall or roll around. If the judges feel that a cylinder is unsafe, they have the discretion to prevent its use.
- j. SCUBA tanks are permitted. They must meet all the above specifications and have a current visual inspection sticker, or “fill permit” visible.

NOTE for 2024!!!

Electronic housings and other enclosures on the ROV must operate at surface pressure. Companies may not pressurize their electronics housing.

[3.6.4 Unpressurized Containers](#)

FLUID-013: Companies may fill containers on the ROV with air provided those containers never exceed ambient pressure. Any such container should have at least one ¼-inch (6.35 mm) hole drilled into the bottom of the container to allow excess air to spill out.

[3.6.5 Pressure Storage Devices \(Pressure Accumulators\)](#)

FLUID-014: Pressure storage devices are allowed on the ROV if they do not exceed 1.25 L in total storage and do not store pressure higher than the allowed pressure for air or hydraulics. It is understood that companies may not be able to purchase a pressure accumulator that has the proper rating and fits in the space needed. In that case, the company must show that their designed accumulator is capable of withstanding the specified pressures without rupture.

[3.6.6 Chemical Creation of Gases](#)

The chemical creation of gases is not permitted.

3.6.7 Fluid Power Quiz

FLUID-015: RANGER class companies planning to use hydraulics and/or pneumatics (i.e., fluid power) are required to take and pass an online quiz with a score of 100%. Companies ONLY using manual pumps and unpressurized containers are not required to take the Fluid Power Quiz but must still submit documentation regarding their fluid power system.

NOTE: The quiz was developed by MATE ROV Competition technical support staff and competition judges and is designed to ensure that companies understand basic information on these topics and can apply that knowledge to safe practices. The intention is not to add yet another “requirement,” but rather to provide a safe and successful learning experience and competition environment.

The quiz should be completed by the STUDENT company members. Each member of the company does NOT have to take the quiz; students can work together and make it a group effort. **ONLY ONE TEST PER COMPANY.** The company’s instructor or mentor can provide guidance and advice, but the questions should be answered by the students participating on the company. The quiz will be scored, and the results provided instantaneously. A score of 100% is considered a passing grade. Companies can take the quiz as many as 5 times to achieve this score.

The quiz must be completed with a passing grade by April 26th, 2024. NO EXCEPTIONS OR EXTENSIONS! Companies with regional competition prior to April 26th due date should plan to take the fluid power quiz at least 2 weeks prior to their competition. If registration for your regional competition opens after the fluid power closing date, you must still take the quiz before April 26th. Companies failing to complete this quiz within the given time frame will NOT be permitted to use fluid power during their competition event. **NO EXCEPTIONS OR EXTENSIONS! See [6.2 KEY DEADLINES](#).**

To purchase and take the fluid power quiz, click [here](#).

The following are sources of information on hydraulics and pneumatics. This is not intended to be an exhaustive list, but rather a starting point to encourage companies to seek out additional information and resources.

- [Underwater Robotics: Science, Design, and Fabrication \(Revised Edition\)](#), published by the MATE Center and MATE Inspiration for Innovation
- <https://www.nfpa.com/home/About-NFPA/What-is-Fluid-Power.htm>
- <https://www.quincycompressor.com/tips-for-working-safely-with-compressed-air/>

3.7 Control Systems

ELEC-021R RANGER companies are not limited to the type of control system they may use provided it complies with the other MATE design and safety specifications.

ELEC-022R: Surface control stations must be built in a neat and workmanship-like manner. Loose components and unsecured wires will not pass safety inspection.

ELEC-023R: Surface control stations by nature may combine 120 VAC and 12 VDC wiring. The surface control stations must be wired in a manner such that the 120 VAC wiring is physically separated from the DC wiring, the 120 VAC wiring is clearly identified from the DC and control voltages, and every conductor is insulated in a manner that no conductor is exposed. Identification can be through signage and/or wire color schemes. All 120 VAC wiring colors must use ANSI, NEMA or IEC standard wiring colors appropriate to each voltage. There must be a sign inside the surface control station indicating which wiring standard is being utilized. Companies that do not have adequate separation of AC wires and components and DC wires and components will NOT pass the safety inspection. It is recommended that separation be designed into the control system to keep power systems separate. Wiring should be clear, neat, and easy to follow by inspectors. Wiring “rat’s nests” or “spaghetti wiring” will not pass safety inspection.

ELEC-024R: Companies must use proper strain relief and abrasion protection where wires and the tether enter the vehicle. The ROV should be capable of being lifted by the tether without damaging the tether connection to the ROV. Tape, glue, zip ties, and other quick methods of strain relief are not acceptable. The intent is to see the wires pass through a connector specifically designed to provide strain relief.

Companies must use proper strain relief at the surface where wires and the tether enter the control system. Pulling on the tether should not strain the wires entering the control system.

NEW for 2024!!!

Additional information on expected and accepted practices for design and wiring of your system, including proper strain relief, can be found in the following MATE ROV Competition Tech Bulletin:

- [Tech Bulletin – MATE Expected Work Practices](#)

ELEC-025R: Any connectors utilized in the surface control station and elsewhere in the ROV system must be properly type rated for their application. AC rated connectors must not be used for DC. The connectors must also be rated at or above the voltage and current used in their application.

3.8 Command, Control, & Communications (C3)

3.8.1 Power Provided

CCC-001: Surface power: MATE will provide one GFI-protected outlet with a nominal 115 Volts AC (60 Hertz) and 15 amps maximum. This outlet is intended to provide power for pumps and other surface support equipment (e.g. video monitors & control boxes). This AC power source CANNOT be used to directly or indirectly power the vehicle.

CCC-002: If hydraulic or pneumatic power is used for vehicle thrust, the power for the pump must come from the MATE supplied DC power supply.

CCC-003: In addition to electric pumps, hydraulic, and pneumatic systems can be powered by manual pumps (e.g. bicycle tire pump) or supplied from a pre-pressurized cylinder. Companies that are only using manual pumps must still comply with all hydraulic and pneumatic specifications, including the creation of a fluid power SID.

3.8.2 Displays

CCC-004R: **NOTE in 2024!!!** Companies are limited to a maximum of three live video display screens. Companies may use an additional three displays for ROV status or sensor information.

Capturing a still image of a video display on a cell phone or tablet for the purpose of completing a product demonstration task does not count as an additional display.

CCC-005R: These display devices may be powered by the MATE provided GFI-protected 115-volt AC (60-cycle) and 15-amp AC power source described in CCC-001, Surface power.

CCC-006R: A company's C3 station may include devices like video recorders. All C3 devices must be able to run on the single AC power outlet provided or on its own internal battery power. Any device plugged into this AC power outlet can only provide C3 functions and cannot provide power to the ROV.

CCC-006R: A company's C3 station should have all items stable or secured to the station. Large monitors not secured to and stable in the product demonstration station are not permitted. Monitors and other C3 devices with glass faceplates are not permitted.

3.9 MATE Provided Equipment

For companies advancing to the World Championship, the MATE ROV Competition will NOT provide video monitors at the product demonstration stations. Contact [your regional coordinator or visit your regional contest's website](#) as to whether video monitors will be provided at your regional competition.

In 2024, the MATE ROV Competition will supply compressed air at each station during the World Championship. Companies may connect to this compressed air via a [standard ¼-inch NPT male fitting](#). Contact [your regional coordinator or visit your regional contest's website](#) as to whether compressed air will be provided at your regional competition.

3.9.1 Companies Sharing Equipment

Companies may be allowed to share the following equipment during the competition event: monitors and joysticks/controllers.

Companies may NOT share the following equipment during the competition event: control systems and payload tools (e.g. grippers, manipulators).

Contact [your regional coordinator or visit your regional contest's website](#) to determine if equipment can be shared at your regional event.

Companies that plan to share equipment during the World Championship event must notify the [Competition Technical Manager](#) at least 4 weeks prior to the event so that this can be considered when creating the schedule. MATE will do its best to accommodate companies sharing equipment.

3.10 Laser Safety Rules

LASR-001: **Companies must forward the specifications of their laser to the [Competition Technical Manager](#) by May 15th, 2024. Specifications MUST include a link to the laser being used. The link should include a photo of the laser and the laser specifications.** A notification will be sent to the company when the laser is approved. Companies must also bring a copy of their laser specifications to their safety checks. If the laser is being used at a regional event or pool practice, notification will also be sent to the regional competition coordinator.

LASR-002: All lasers must operate in the visible range at either the 630-680 nm (red) or near the 532 nm (green) wavelength. All lasers must fall into the Class I, Class II, or Class IIIa category. Red lasers must operate at 5mW or less. Green lasers must operate at 1 mW or less.

LASR-003: Companies should include detailed specifications of their laser in their technical documentation as well as have that information ready and available during their safety inspection and engineering presentations.

LASR-004: Lasers must have an on/off switch. This switch must be on the surface controller.

LASR-005: All lasers must be powered by the MATE surface power supply. Batteries, including batteries for powering lasers, are not permitted on the vehicle.

LASR-006: Companies using lasers cannot increase the voltage or the current to increase the power of their lasers. Lasers must use the voltage and current set in their specifications.

LASR-007: When out of the water, the laser should have a shield or enclosed beam stop attachment within 30 cm of the laser. This means that the laser beam should not travel more than 30 cm before reaching the shield. This is a requirement at all times when the laser is out of the water. **Note for 2024!!!** The beam stop must be attached to the ROV at all times. Companies may not remove the beam stop by hand when the ROV enters the pool. The beam stop should be designed so it floats or moves out of the way of the beam when the ROV is in the water. The shield must be painted with FLAT BLACK paint.

LASR-008: At no time should the laser be focused or deviate from a collimated beam.

LASR-009: When testing the laser at a workstation, companies must display a sign telling others that a laser is being operated.

LASR-010: Operators working with the laser while the ROV is out of the water should wear appropriate laser safety glasses at all times. This requirement is for all laser types. Search online to find laser safety glasses appropriate for the wavelength being used.

Companies must forward the specifications of their laser safety glasses to the [Competition Technical Manager](#) by May 15th, 2024. Specifications MUST include a link to the laser safety glasses being used. The link should include a photo of the laser glasses and the laser specifications. A notification will be sent to the company when the laser safety glasses are approved. Companies must also bring a copy of their laser safety glasses specifications to their safety checks. If more than one brand of glasses are used, a copy of each specification sheet should be provided.

The following lasers are acceptable to use in the MATE ROV Competition, although companies may choose to use alternate lasers. NOTE: **ALL COMPANIES MUST FORWARD SPECIFICATIONS TO THE COMPETITION TECHNICAL MANAGER, EVEN IF ONE OF THE FOLLOWING LASERS IS USED.**

- [Amazon.com: HiLetgo 10pcs 5V 650nm 5mW Red Dot Laser Head Red Laser Diode Laser Tube with Leads Head Outer Diameter 6mm: Industrial & Scientific](#)
- [Amazon.com: Quluxe 650nm 5mw Laser Head Laser Tube Adjustable Focus 3~5V Red Laser Tube, Laser Head Industrial Laser \(Pack of 3\) : Industrial & Scientific](#)

PART 4: COMPETITION RULES



Teamwork/
Collaboration



Content
Knowledge



Safety



Vehicle Design,
Buoyancy, Propulsion

4.1 GENERAL

- All members of the company and their supporters must follow the safety regulations of the ROV competition, pool facility, and event venue.
- All company members and their supporters are expected to conduct themselves in a professional and responsible manner during the competition. Disrespectful behavior towards the judges, officials, pool staff, audience, or other companies will lead to penalty points or disqualification.
- Sabotaging, stealing, or pilfering equipment of other companies will lead to disqualification. Companies found cheating will also be disqualified.

- The MATE ROV competition is, at its core, designed to be an educational and inspirational event for **STUDENTS**. It is designed to challenge them to apply the physics, math, electronics, and engineering skills they are learning in the classroom to solving practical problems from the marine workplace. (See the [MATE Competition Philosophy](#).)

It is expected that all “adults” (non-students; e.g. teachers, mentors, parents) involved in the competition limit their input to educational and inspirational roles. Actual construction of the ROV (particularly in the complex electrical and software areas) must be completed by the students. Adults should teach and advise students about design, electronics, software, and construction, but not complete the work for the students. Throughout the process adults are encouraged to focus on benefits to the students from the process and not simply winning. If it becomes apparent that adults exercised more than an advisory role, judges reserve the right to deduct points or, in extreme cases, disqualify companies from the competition.

ALL work done on the vehicle must be conducted by company members. This includes any work done at home, at school, or during the MATE ROV competition (World Championship and regional). Teachers, mentors, parents, and non-competing students are not permitted to work on the ROVs. They may provide advisory input, but they may not work on the ROV directly. This includes writing or editing software code. All mechanical, electrical, and software modifications and/or repairs to the ROV must be completed by students.

With learning at its core, the MATE competition encourages students to utilize and build upon their skill sets to find creative solutions to designing and building their ROV. Students gain valuable skills and knowledge when creating a component from “scratch,” which is apparent to judges as they review the technical documentation and engineering presentation. However, as they move through the process of analyzing their designs and identifying building materials, students may decide to either build a component from “scratch” or purchase it from a commercial vendor.*** So, while original solutions are encouraged, the use of commercial components is acceptable, provided 1) that the components adhere to the design and building as well as safety specifications for the particular competition class and 2) more importantly, that the students can provide a reasonable, logical explanation for buying versus building.

The competition scoring rubrics are designed to reflect this; points are awarded based on students’ abilities to explain and justify how all of the components and systems work together as an integrated ROV, regardless if they purchased them, pulled them from public libraries, or made them themselves.

***Note “commercial vendor” includes the [SeaMATE store](#) and other competition programs that sell educational robotics kits. SeaMATE kits were created to remove barriers to participation for teachers and schools unable to easily 1) find parts and materials and 2) set up accounts with multiple vendors. The kits are part of a larger educational package that includes curriculum materials, videos, and other resources to support and enhance learning. And learning is what

students who use SeaMATE (or other) kits will be expected to demonstrate during and through the [ENGINEERING & COMMUNICATION](#) components.

It should be noted that purchasing and competing with complete, assembled, commercial ROVs is not permitted.

4.2 PROCEDURAL

- Companies must compete during their assigned time slots. Your company is **NOT** permitted to switch time slots with another company. Failure to show for your scheduled product demonstration or for your company's engineering presentation will result in "no score" for that particular competition category. **No exceptions.** Assigned time slots will be sent out in advance so that any scheduling concerns can be addressed prior to the event.

*Regional contests may refer to the product demonstration station as the control "station" or "shack."

- Companies must complete their weight measurements before each product demonstration run. The weight measurements are included as part of the product demonstration score. Companies should be at the weigh in area at least 20 minutes before their scheduled product demonstration run.
- While there is no limit to the number of students who can compete as part of a company, **the product demonstration team (aka demo team) is limited to six students.** **Note for 2024!!!** At the World Championship, two additional members are allowed to deploy, operate, and recover the vertical profiling float. The demo team is defined as the team of students who operate the vehicle and its associated equipment during the product demonstration. Only six students will be allowed to enter the product demonstration station, launch, pilot, and perform the tasks, with two more operating the vertical profiling float. Instructors, mentors, and/or non-student members cannot participate as part of the demo team. **Companies may alternate students on the demo team for the two product demonstration attempts.** (All members of the company should participate in the engineering and communication components; see [ENGINEERING & COMMUNICATION](#) for more information.)
- Only the demo team members and judges are allowed at the product demonstration station during the product demonstration, which includes the set-up and demobilization periods. Other members of the company, instructors, mentors, audience members, and observers (press or special invited guests) must remain outside the product demonstration station or in designated viewing areas.
- Instructors, mentors, parents, and "fans" are **NOT** permitted at the safety inspection stations or repair tables. Two warnings will be issued before individuals not heeding this rule will be asked to leave the venue.

- In addition, instructors, mentors, parents, and fans are **NOT** permitted to work on the ROV. Individuals who are seen working on the ROV who are not student company members will be issued a warning. Two warnings will be issued before individuals not heeding this rule will be asked to leave the venue. If companies choose to take their ROVs off the competition grounds for maintenance and repair, they are expected to observe this rule in the interests of the spirit of the competition.
- To help enforce this, teachers, mentors, parents, and non-competing students MAY have limited access to the workstation areas. Contact the [MATE ROV Competition officials](#) for more information.
- Video devices may be used to record the underwater activities for entertainment and learning purposes **only**. Video will not be used as an instant replay to review judges' decisions or to challenge product demonstration timing.
- Product demonstration stations will be roped off and marked. Product demonstration stations will contain 2-3 chairs and one 6-foot table long table for companies to use. This table will be within 3 meters of the pool edge. Product demonstration stations will be set up to prevent the pilot(s) from looking at the ROV in or under the water except through the ROV cameras.
- Companies will compete in one product demonstration that will consist of four tasks. Companies will get TWO attempts at the one product demonstration. The higher of the two scores will be added to the engineering and communication score to determine the total, overall score for the competition.
- The product demonstration time consists of a 5-minute set-up period, a 15-minute performance period, and a 5-minute demobilization period. If the demo team and all of their equipment are not out of the product demonstration station at the end of the 5-minute demobilization period, the company will be **penalized 1 point for each additional minute**.

Note: Regional competitions *may not* offer two attempts at the product demonstration. Regional competitions may allow more or less time to complete the product demonstration. [Contact your regional coordinator or visit your regional contest's website](#) for more information.

- Manipulating the tether to free it from underwater obstacles is permitted. Pulling on the tether to speed up the recovery of items or to return your vehicle more quickly to the surface is not permitted and will result in penalty points. Judges will issue one warning if tether pulling occurs. Each future infraction will result in **5** points deducted from the final product demonstration score.
- SCUBA diver assistance will be available at the World Championship. If help is required, the company CEO or pilot must ask a station judge and divers for assistance. Each diver assist will incur

a 5-point penalty. The product demonstration clock will not stop if a company is receiving diver assistance.

Diver assistance may not be available at your regional competition. [Contact your regional coordinator or visit your regional contest's website](#) to determine if diver assistance will be available at your regional competition.

- Pilots can only leave the product demonstration station and move poolside to repair, adjust, or alter a vehicle if the ROV is surfaced and at the side of the pool.
- Companies are not permitted to leave debris in the pool. Any debris must be recovered by the ROV before time has expired or the company will be penalized. Debris is defined as pieces of the ROVs, weights, floats, or other items created by the company. Task props are also not considered debris. The product demonstration notes section may cover special items that can be left in the pool after time has expired.
- No demo team member shall enter the water to complete an object recovery. Only arms and hands are allowed into the pool to retrieve an object or to retrieve the vehicle. Companies will be disqualified or penalized depending on the severity of the infraction.
- Communication between demo team members at the pool edge and demo team members piloting the vehicle will be limited. Only tether management issues (e.g. how much tether is out, how much is remaining on the pool deck) can be discussed. Those team members at the pool edge cannot give any directional or product demonstration task information to the pilot. Judges will issue one warning regarding illegal communication. Each future infraction will result in 5 points deducted from the final product demonstration score.
- Communication using cell phones, text messaging, and online social media tools such as Teams, Zoom, Skype, Facebook, Twitter, instant messaging, etc. is NOT permitted during the product demonstration, either between the demo team members at poolside or between any demo team member and anyone outside of the product demonstration station. The ROV and/or the ROV control system is not allowed to broadcast video or other information to anyone outside of the product demonstration area. No exceptions. Companies found broadcasting any data to those outside of the product demonstration area will be disqualified.
- **Product demonstration judges and other competition officials will only communicate with students.** Judges and officials will NOT communicate with mentors, parents, or other non-student members regarding product demonstration information, challenges, or other issues except during pre- and post-competition briefing sessions.

Companies that wish to issue a challenge during the product demonstration run should immediately communicate this challenge to the product demonstration judges. The judges will discuss and

attempt to resolve the issue. If a decision cannot be made, the product demonstration judges will consult with the head judges and competition technical manager to resolve the issue.

- **NOTE for 2024!!!**

Once a chief judge rules on a challenge, that ruling is final. NO EXCEPTIONS, including appeals to other competition officials. Penalty points may be given if companies continue to pursue the challenge beyond the chief judge's final ruling.

4.3 DESIGN & SAFETY CONSIDERATIONS

- The competition coordinators and host venues stress the importance of safety practices and procedures to all companies. The score sheets and rubrics will reflect the MATE ROV Competition's efforts to encourage and reward companies that demonstrate exceptional safety practices and procedures.
- **ALL ROVS MUST PASS A SAFETY INSPECTION CONDUCTED BY COMPETITION OFFICIALS PRIOR TO ENTERING THE POOL.** These inspections will be conducted topside to ensure that ROV systems meet the design and building specifications and do not pose a risk to the integrity of the event venue. See [VEHICLE DESIGN & BUILDING SPECIFICATIONS](#) for additional information.
- Radio transmitters that operate on a separate battery are permitted. No batteries are permitted to be in or on the water. No exceptions.

Companies should be aware of all the implications of these wireless devices. There is no assurance that an adjacent company's wireless controller will not interfere with your control systems. Adjacent wireless controllers with a battery that has a higher charge than the nearby controller have demonstrated the ability to "hijack" the nearby control signals. In addition, all wireless controllers are susceptible to external sources of electronic interference. Your system may work fine in your home environment, but not in the industrial environment of the competition. MATE will not stop the clock to resolve wireless control issues. Companies deciding to utilize wireless controllers do so at their own risk.

- Keep an eye out for tripping hazards in the product demonstration station and at your company's workstation. Make sure power cords are not laying in pools of water on the deck.
- During your product demonstration, be sure to secure any equipment so that it does not fall off the product demonstration station table, damage the deck, or cause injury.
- Loose fitting clothing, jewelry, and long hair could all become safety issues. Consider securing long shirts or baggy pants, removing jewelry, and tying back long hair when working on or operating your ROV.

- ROVs may be constructed out of materials of your company’s choice, provided they meet the design and building specifications and safety regulations. Warning labels should be posted on potentially hazardous components of your ROV system.
- Close-toed shoes are required on the pool deck. Safety glasses are required when working on the vehicle.
- Personal flotation devices (PFDs) will not be required at the World Championship. No personal flotation devices will be provided by MATE or the host venue. Regional events may require PFDs. [Contact your regional coordinator or visit your regional contest’s website](#) to determine if PFDs will be necessary.

PART 5: ENGINEERING & COMMUNICATION



NOTE for 2024!!!

MATE has created an ROV Competition [Marketing Kit](#) that includes logos and guidelines for their use.

The ability to communicate information about your vehicle and the design and building process is equally as important as how well your vehicle performs. Strong communication skills are an essential part of good business practices and one of the most in-demand skills in the constantly evolving, ever-changing workplace.

To emphasize this point, the competition requires the following five engineering and communication components:

- Company spec sheet
- Technical (written) Documentation (Examples of spec sheets and technical documentation from previous competitions can be found in the [MATE ROV Competition Archives](#).)
- Engineering (oral) presentation (Videos of engineering presentations can be found on the MATE Vimeo site: [Jesuit High School](#) (EXPLORER 2019), [404 Engineering](#) (EXPLORER 2021), [Hawks](#)

[Engineering](#) (RANGER 2021), [Deep Ocean Robotics](#) (RANGER 2021) and [Sea Life Technologies](#) (RANGER 2021).

- Marketing display (Photos of marketing displays can be found on the MATE ROV Competition Flickr site: [Hong Kong UST EPOXSEA](#) (EXPLORER 2023), [Cabrillo College](#) (PIONEER 2023), [MTL Horizon](#) (RANGER 2023.)
- Corporate Responsibility (OPTIONAL)

NOTE: Regional contests may not require all of the Engineering & Communication components. Contact [your regional coordinator or visit your regional contest's website](#) for more information.

See the TIPS FOR EFFECTIVE WRITTEN AND ORAL COMMUNICATION for additional information.

NOTE for 2024!!!

Your company should refer directly to the scoring rubrics posted under [Scoring](#) for details on what is required for your technical documentation, engineering presentation, and marketing display. The judges will use the rubrics to evaluate and score these engineering and communication components.

5.1 COMPANY SPEC SHEET

The purpose of the company spec sheet is to provide the judges with a “snapshot” of your company. It includes basic information about your company and vehicle.

Company spec sheets will be reviewed by MATE competition coordinators. Companies will receive up to 20 points for submitting a spec sheet that is **one page** in length, follows the file size and naming specifications, and contains **all** of the following information:

COMPANY SPECS

- **Company and school, club, or community organization name**
- **Home state and/or country**
- **Distance required to travel to the World Championship**
- **History of MATE ROV competition participation.** Be sure to specify if your company and/or the members of your company are “new” or “returning.”
- **Company photo and caption indicating members’ names and roles (e.g. CEO, CFO, Design Engineer, Pilot, etc.).** This photo should include all of the members of your company.
- **Range of grade/college levels represented by the members of your company**

ROV SPECS

- **ROV name** if applicable
- **Total cost.** You must include the approximate cost of any donated items.
- **Size and weight measurements**
- **Total student-hours to design and build.** This should include the number of hours that each and every member of the company worked on the vehicle.

- **Safety features**
- **Special features**
- **Photo of the vehicle**

REMINDER!!! If all of the above information is included, the specifications for length, size, and naming conventions are followed carefully, and the document is submitted on time, this is an “easy” 20 points! You can find the company spec sheet scoring rubric posted [here](#).

5.2 TECHNICAL DOCUMENTATION

The purpose of the technical documentation is to challenge you to effectively and efficiently communicate information using clear and concise text along with graphics, illustrations, and data that add to and complement (and not distract from) the information. Your company must organize and present the information in a way that is logical and complete. The document should focus on the technical and safety aspects of your ROV/ROV systems, the design rationale behind your engineering decisions, and a critical analysis of testing and troubleshooting done on the vehicle. You should consider this document a reference for both judges and future team members (part of the company’s institutional knowledge).

Your company’s technical documentation will be reviewed and evaluated by a panel of working professionals – individuals who represent science, exploration, government, and industry. (Don’t assume that these same individuals will evaluate your company’s engineering presentation!)

Each judge on the panel will award a score (100 points max). Judges’ scores and comments will be returned to you shortly after the event.

NOTE: The judges will not review and rescore revised versions of your technical documentation during the competition.

Use the technical documentation scoring rubric posted [here](#) as the guideline for the required components for the technical documentation. This rubric will be posted by March 1, 2024. In the meantime, companies may refer to the [previous year’s rubrics](#) for a general idea of the categories and points.

5.3 ENGINEERING PRESENTATION

The purpose of the engineering presentation is to challenge you to effectively and efficiently communicate information with words and “props” (i.e., the ROV). Your company must organize and present the information in a way that is logical and covers the development and testing of your ROVs and the formation and development of your team. The presentation should be delivered as a “technical brief,” with references to the technical documentation for additional details (companies should present judges with ONE copy of their document at the start of the presentation). The presentation is THE

opportunity your company has to 1) communicate directly and in person your critical thinking, creativity, and engineering reasoning (including build vs. buy) and 2) demonstrate your individual and collaborative contributions to the creation of the vehicle.

During the competition, your company will have 15 minutes to deliver your presentation to a panel of working professionals – individuals who represent science, exploration, government, and industry. (Don't assume that these same individuals will evaluate your company's technical documentation!) After the presentation, the judges will take 10-15 minutes to ask the members of your company questions about your ROV. The judges will evaluate both your presentation and responses to their questions. Each judge on the panel will award a score (100 points max). Judges' scores and comments will be returned to you shortly after the event.

All student members of your company must be prepared to participate in this presentation and the question and answer (Q&A) period. You are required to have your ROV with you. For larger companies, the main presentation may be done by a subset of the overall company. During the Q&A, all members of the company should be prepared to answer. However, if one student is better suited to answer a specific question, the others may defer the question to that student to answer. For example, if a judge calls on the pilot to answer a question about the tether, the pilot can respond by informing the judge that the tether manager was the lead on that system and allow the tether manager to answer without penalty or loss of points.

NOTE: The engineering presentation is designed to be a face-to-face interaction where students and representatives from industry become engaged in conversation. MATE will not provide audio visual aids, such as slide projectors, computer projection screens, white boards, etc.; however, you are welcome to distribute handouts to help judges better understand the information that you are presenting. Electronic forms of presentation (e.g. PowerPoint or Keynote slides) **are NOT permitted.**

Instructors, mentors, family members, friends, and members of other companies are permitted to attend. However, we ask that those in attendance be respectful and courteous throughout the presentation and follow-up question and answer period. Be mindful that this presentation may be a stressful time for the students. If the room becomes crowded or the spectators become distracting, it is up to the judges' discretion to request that some or all spectators leave the presentation. **While they are permitted to attend, instructors and mentors are not allowed to participate.**

Use the engineering presentation scoring rubric posted [here](#) as the guideline for the required components for the engineering presentation. This rubric will be posted by March 1, 2024. In the meantime, companies may refer to the [previous year's rubrics](#) for a general idea of the categories and points. Judges may ask questions regarding any of these topics not covered in the presentation as well as other questions about the vehicle, the mission theme, or the company.

Preparing for your engineering presentation and Q&A

- Make sure that every member of your company has a good, general working knowledge of your vehicle, even though they may have specialized in one specific aspect of its design and construction.
- Make sure that all the members of your company are familiar with your technical documentation. Ask every member to read it over to catch any errors or omissions. This exercise will help to familiarize everyone with all aspects of the project.
- Generally, you will have more to say about your ROV than can be presented in 15 minutes. That is why it is critical to organize your material and practice communicating it. However, avoid coming across as having memorized your presentation verbatim. Judges want to see that you are prepared and understand the information, not that you can simply regurgitate a rehearsed speech from memory. Ask your instructors or mentors to give you feedback.

Other important items

- If during the engineering presentation it becomes apparent that instructors, mentors, and other adults associated with your company exercised more than an advisory role, judges reserve the right to deduct points or, in extreme cases, disqualify companies.

5.4 MARKETING DISPLAY

The purpose of the marketing display is to challenge you to present technical information in a way that appeals to and is understood by a non-technical audience. It is the promotional piece – you must not only present information about your ROV and your company, but you must also use graphics and design to publicize and “sell” (convince viewers of their value and excellence) your products and people.

During the competition, your company’s display will be evaluated and scored by a completely different group of working professionals – individuals who will represent science, business, government, industry, and education/outreach.

While some judges will have a technical background, others will have a communications, marketing, or public relations background. In addition, there will be visitors to the competition who may not completely understand what an ROV is or how it is used. Think of these visitors as potential future clients who may authorize funding for your work but have a limited understanding of the technology (i.e., you need to explain your technology, the tasks at hand, and “sell” them on YOUR products and services). Design your display to communicate to this type of audience.

Each judge will award a score (50 points max). Judges’ scores and comments will be returned to you shortly after the event.

WORLD CHAMPIONSHIP COMPETITION ONLY!

NOTE: The MATE ROV Competition will NOT supply display boards.

You must provide your own display board. The space that the text and photographs/graphics occupy CANNOT exceed 36" tall by 48" wide. For example, company names CANNOT be mounted above the display board. NO EXCEPTIONS!

At the World Championship, either easels or tables will be provided for the displays. Contact [your regional coordinator](#) to see if tables (easels or other) will be provided at your regional event. Companies should create their marketing displays so that they can be exhibited on either a table or an easel.

MATE will continue to provide scissors, tape, glue sticks, adhesives, and other means of attaching display items to the presentation board, although you are also welcome to bring your own.

Use the marketing display scoring rubric posted [here](#) as the guideline for the required components for the marketing display. This rubric will be posted by March 1, 2024. In the meantime, companies may refer to the [previous year's rubrics](#) for a general idea of the categories and points.

Creating an effective marketing display:

- Address the theme and make real-world connections.
- Reflect your company's personality and mindset.
- Make key points and be concise.
- Keep the general public in mind.
- Make sure to label any and all figures, graphs, diagrams, and photographs and credit the source.
- Maximize the use of the 36" by 48" display space.
- Make sure that it is both informational and aesthetically pleasing.

Note: "Accessories" such as video footage, PowerPoint slide presentations running on laptop computers, video projections, etc. are permitted but should be used with discretion. Remember that the judges will have a limited amount of time to evaluate your marketing display and may find excessive use of audio or video presentations distracting.

However, if you do make a video of your ROV building or competition experience, please submit information about it to the [MATE ROV Competition officials](#) so that it can be shared via MATE's YouTube and Vimeo channels.

5.5 CORPORATE RESPONSIBILITY

The MATE ROV Competition uses underwater robotics to inspire and encourage students' interest in STEM (science, technology, engineering, and math) education and careers. Recognizing that the students who participate in MATE competitions are powerful ambassadors for the program as well as effective leaders in raising awareness of important issues and bringing about positive change, companies have the opportunity to earn up to 20 points for "corporate responsibility."

Corporate responsibility includes, but is not limited to, the following:

- **Mentoring** consists of, for example, providing guidance to other students in your area who are designing and building an ROV for the competition or a science or other project.
- **Engaging the community** includes demonstrating your ROV and sharing information about your company at festivities and other community-wide events. Presenting to a Rotary Club or your school district's board of directors are other examples.
- **Media outreach** consists of:
 - o Developing a list local media contacts
 - o Writing a press release about your participation in the MATE ROV competition
 - o Distributing it to your media contacts
 - o Following up with your media contacts to see if they're interested in your company and its ROV
 - o Compiling a summary of results

Here are some [general guidelines](#) for working with the media. They are specific to the World Championship, but can be easily modified for regional events.

- **Raising awareness of environmental, social, and governance (ESG) issues.**
- Corporate responsibility efforts will be reviewed by competition coordinators and awarded 0 to 20 bonus points, depending on the number and scope of the outreach and awareness activity(s), i.e., the number of other students or members of the community engaged, the number of mentoring sessions, etc.

Make sure to include the following information in your write-up:

- Type of activity (e.g. mentoring, exhibiting at a community event, raising awareness)
- Locations, dates, and the amount of time spent on the activity
- Number of students or community members (if a large event, this can be an approximate) involved
- Description of your actions, outcomes, and other information that helps to demonstrate the quality of your time and efforts
- For media outreach, please submit a copy of your press release, a copy of your media contacts list, and a summary of news articles, TV or radio coverage, etc. that your company received. Include copies of articles and URLs, and list any television or radio coverage. Be sure to include name of outlet, date, and a summary of the coverage.

TIPS FOR EFFECTIVE WRITTEN AND ORAL COMMUNICATION

Communicating ideas about how to solve a problem and evaluating those ideas against competing alternatives is a critical skill for anyone entering the workplace. It is a skill that is directly linked to decision making about whether or not to hire (or fund) us and our ability to influence the work that we do.

The key to a successful technical documentation and engineering presentation is the way that critical thinking and engineering reasoning are communicated. You can think of the process as technical “storytelling.”

Technical storytelling includes the use of text, images, schematics, and data to effectively communicate the “story” of how your company brainstormed and evaluated ideas to come up with your solution (e.g. ROV, payload tools, and operational strategies) to the problem at hand (product demonstration tasks). It also involves organizing content to efficiently present your work and justify why you did what you did.

However, you should choose details with care. Each detail should help to answer the question "why is what you did the best solution for your company and for this competition?" Describe why a component in the system is critical and how you chose it. Include specifications or dimensions only if they help to explain the “why” and “how” you made choices. Keep in mind that a mechanical drawing with dimensions can replace a lot of text and in many cases do a better job telling details of the story than text.

That said, if something is hard to describe clearly and completely with two to three sentences, consider whether using an image may help. A good technical document balances text and images to provide lots of information concisely, which for a detailed understanding while being quick and easy to read. Remember that your reader is new to your design and needs to understand both what your design is and the process you used to get there. Present text and images in a logical order that helps readers follow your development process and results.

Maintaining a project notebook is a good business practice that will help to capture ideas and document your company’s progress – including your research, designs, trade studies, experiments, data, vehicle specifications, testing, expenditures, and donations. The notebook is also a place to keep track of your company member’s contributions (time, support, etc.).

Along with your notebook, here are some items to consider as you prepare to tell your story:

- What was your company’s "work breakdown structure" (tasks, time, and people)?
- What were the greatest constraints (schedule, budget, equipment, labor, logistics, etc.) on your design process?
- How did the product demonstration tasks and rules influence your design and decisions?
- What systematic process, such as a tradeoff matrix, did you use to evaluate competing design solutions?
- What were the most important design decisions you made and why?
- How did you arrive at your final power budget? What concessions, if any, did you have to make and why?
- How do you calibrate your sensors?

- If your vehicle uses software, where does the code execute? Describe the flow and format of the data.
- Did you have a noteworthy troubleshooting experience? Any problem or procedure that takes more than 20 minutes to figure out is worth understanding and writing down.

PART 6: SUBMISSION GUIDELINES AND KEY DEADLINES



Communication



Autonomy



Obstacles



Project Management

6.1 Documentation

Companies advancing to the World Championship are required to submit technical documentation, a company spec sheet, a SID, a fluid power diagram (if fluid power is used), and a company safety review. In addition, companies may submit a JSA and documents supporting their corporate responsibility efforts. If companies are using a non-ROV device, they must submit a non-ROV device design document and a non-ROV device SID. Also, if companies plan to transplant the brain coral autonomously, they must submit an explanation of their program and copy of their code.

NOTE: By submitting your documentation, you are giving the MATE ROV Competition permission to publish these documents on its web site.

Regional competitions may not require all documentation. Contact [your regional coordinator or visit your regional contest's website](#) to determine what documentation must be submitted for your regional and the date it is due.

NOTE for 2024!!!

The links provided in this section are for companies advancing to and submitting documentation for the World Championship. Regional coordinators will provide their own link for regional submissions.

Regional submissions sent to the MATE ROV Competition management team or to World Championship officials are NOT guaranteed to be forwarded to the regional coordinator.

DOC-006: All required documentation sent to the MATE ROV Competition officials MUST be in searchable PDF format (see <https://fd4686477cb19f983f54-68abf00cbc1a2cc111562c013cb867db.ssl.cf1.rackcdn.com/SearchablePDFs.pdf> for information about creating searchable PDFs).

DOC-007: The technical documentation may be up to 8 MB in size, the other documents are restricted to a maximum file size of 2MB.

DOC-008: All documents should use the following naming convention: School or organization name_company name_DOCUMENT TYPE_2024.pdf, where DOCUMENT TYPE is technical

documentation, spec sheet, SID [type – electrical or fluid], non-ROV device design, company safety review, or JSA.

See [Documentation Submissions Guidelines](#) for information on submitting your documentation. **Submit all of your final documents** in one email. Revised documents submitted at a later date will not be accepted. The MATE competition will use the date-stamp on your form to determine your initial submission.

Before submitting documentation, check to verify that all the files have been attached. Once submitted, companies should verify that all the proper documents were uploaded. If there was an error while submitting your documents, contact the [MATE ROV Competition](#) and upload **ALL** documents again.

DOC-009: For the World Championship, due date for the required documentation is 11:59 PM, Hawaii Time Zone, on May 22, 2024.

DOC-010: Companies will lose points on their initial safety and documentation review if documents:

- 1) Are submitted late
- 2) Exceed the size limit
- 3) Use improper naming conventions
- 4) Are not submitted on ONE form

6.1.1 Video Demonstration Requirements

ONLY FOR THOSE TEAM PROHIBITIVELY FAR FROM A REGIONAL EVENT!

DOC-011: See [Documentation Submissions Guidelines](#) for information on submitting your demonstration videos.

DOC-012: For the World Championship, due date for the video demonstration submissions is 11:59 PM, Hawaii Time Zone, on May 15, 2024.

DOC-013: Videos must be submitted as links to a YouTube or Vimeo post. Companies may submit the specification and product demonstration as two separate videos. Note that the product demonstration portion must be a complete, uncut video.

The video **MUST** indicate the school/organization and the team name, as well as the competition year, 2024.

MATE competition organizers will review the videos and respond by May 19th. Video submissions will **NOT** be accepted after May 15th – **NO EXCEPTIONS**. Video conferences will not be scheduled after May 15th. If the video does not clearly demonstrate that the company's vehicle meets the specifications and accomplishes the tasks, the company is not eligible to participate in the World Championship. No extensions past the due date will be given for any reason.

MATE strongly encourages companies to submit their videos or arrange for a video conference with a MATE official well before May 15th. That way, if an issue is found, companies will have the opportunity to address the issue and submit an updated video, or schedule another video conference, before the May 15th deadline. **Note that it may take MATE up to 5 working days to evaluate a video submission or respond to a request to schedule a video conference.**

NOTE: By submitting your video demonstration links, you are giving the MATE ROV Competition permission to publish these video links on its web site.

6.1.2 Corporate Responsibility Documentation

DOC-011: See [Documentation Submissions Guidelines](#) for information on submitting your corporate responsibility documentation.

DOC-012: The following naming convention should be used for corporate responsibility documentation: School or organization name_company name_Corporate Responsibility ##_2024, where ## is the number of the document uploaded. You can upload a variety of file types (pdfs, jpegs, etc.) and multiple files, but the size of each file should not exceed 2MB. Number each file to distinguish between them.

Before submitting documentation, companies should verify that all the files have been attached. If companies experience an error when submitting documents, contact the MATE ROV Competition and upload **ALL** documents again. Revised documents submitted at a later date will not be accepted. The MATE competition will use the date-stamp on your form to determine your initial submission.

DOC-013: For the World Championship, due date for the corporate responsibility documentation is 11:59 PM, Hawaii Time Zone, on May 22, 2024.

NOTE: By submitting your documentation, you are giving the MATE ROV Competition permission to publish these documents on its web site.

6.1.3 Autonomous Control Program

Companies planning to attempt to transplant the brain coral autonomously must submit the autonomous control program (i.e., the code) and a one-page explanation of the autonomous control program (i.e., how your program works) prior to the event.

NOTE: Regional competitions may not require documentation submissions of your program and explanation. Contact your [regional coordinator or consult your regional information document](#) for more information on whether this submission will be required.

RANGER companies not planning to attempt autonomous delivery of the brain coral do not need to submit documentation.

DOC-014: See [Documentation Submissions Guidelines](#) for information on submitting your autonomous control program.

DOC-015: The following naming convention should be used for autonomous control program documentation: School or organization name_company name_program_2024 and School or organization name_company name_explanation_2024, where program is the copy of the program code and explanation is the explanation of your program code. Both the copy of the program and the explanation should be uploaded as a PDF file, and neither document should exceed 2MB.

Before submitting documentation, companies should verify that all the files have been attached. If companies experience an error when submitting documents, contact the MATE ROV Competition and upload **ALL** documents again. Revised documents submitted at a later date will not be accepted. The MATE competition will use the date-stamp on your form to determine your initial submission.

DOC-013: For the World Championship, due date for the corporate responsibility documentation is 11:59 PM, Hawaii Time Zone, on May 22, 2024.

NOTE: By submitting your documentation, you are giving the MATE ROV Competition permission to publish these documents on its web site.

6.2 KEY DEADLINES

Below is an updated summary of key dates and deadlines for the 2024 MATE ROV competition season. Note that regional competitions will have their own set of key dates and deadlines. For companies attending regionals, [contact your regional coordinator or visit your regional contest's website](#) for more information.

- December 1, 2023: Registration opens (note that registration for the World Championship and individual regional competitions will open as locations and dates are secured).
- April 26, 2024: Last day to register for the fluid power quiz.
- May 15, 2024: Last day to submit laser specifications and hydraulic fluid information specifications. Companies with regional competitions earlier than May 15 should plan to submit specifications early to allow at least 1 week for approval.
- May 15, 2024: [RANGER class video demonstration](#) submission deadline.
- May 22, 2024:
 - Technical documentation
 - Company spec sheet
 - SIDs (including electrical, fluid, Non-ROV Device)
 - Non-ROV device design document
 - Company safety review

- Job site safety analysis (optional)
- Corporate responsibility documentation (optional)
- Autonomous control program (optional)