



2024 COMPETITION MANUAL SCOUT CLASS

RELEASE: DECEMBER 2023



MTS 
marine technology society



2024 MATE ROV COMPETITION:

OBSERVING OUR OCEANS: UNDERSTANDING OUR WORLD AND CREATING OUR FUTURE

SCOUT CLASS COMPETITION MANUAL

For general competition information, including a description of the different competition classes and eligibility requirements, visit [Compete](#).

CONTENTS

OVERVIEW	2
THINK OF YOURSELVES AS ENTREPRENEURS	3
“10 CHALLENGES - 10 YEARS - ONE OCEAN”	4
PART 1: PRODUCT DEMONSTRATION	4
SCORING OVERVIEW	5
TIME	5
CONTEXT & NEED	6
REQUEST FOR PROPOSALS (RFP)	7
SIZE RESTRICTIONS	18
PRODUCT DEMONSTRATION	19
TASK 1: OOI: Coastal Pioneer Array	19
TASK 2: SMART Cables for Ocean Observing	20
TASK 3: From the Red Sea to Tennessee	22
TASK 4: MATE Floats!	26
PRODUCT DEMONSTRATION RESPONSIBILITIES	30
PART 2: PRODUCT DEMONSTRATION PROP BUILDING INSTRUCTIONS & PHOTOS	31
PART 3: VEHICLE DESIGN & BUILDING SPECIFICATIONS	31
2.0 SAFETY	31
2.1 Safety inspection protocol	32
2.2 Safety inspection completed	34
3.0 SPECIFICATIONS	34
3.1. Operational	34
3.2. Mechanical/Physical	35
3.3. Electrical	36
3.4 Onboard Electrical Power	39
3.5 Power Shutdown	39
3.6 Fluid Power	39

3.7 Control Systems.....	39
3.8 Cameras and monitors.....	40
3.9 Lasers.....	40
PART 4: COMPETITION RULES.....	40
4.1 GENERAL.....	40
4.2 PROCEDURAL.....	41
4.3 DESIGN & SAFETY CONSIDERATIONS.....	44
PART 5: ENGINEERING & COMMUNICATION.....	45
5.1 COMPANY SPEC SHEET.....	46
5.2 TECHNICAL DOCUMENTATION.....	47
5.3 ENGINEERING PRESENTATION.....	47
5.4 MARKETING DISPLAY.....	49
5.5 CORPORATE RESPONSIBILITY.....	50
TIPS FOR EFFECTIVE WRITTEN AND ORAL COMMUNICATION.....	51
PART 6: DOCUMENTATION.....	52
6.2 KEY DEADLINES.....	53



This work is licensed under a [Creative Commons Attribution-NonCommercial-NoDerivatives 4.0 International License](https://creativecommons.org/licenses/by-nc-nd/4.0/). Under this license you may download this document. Please give credit to the MATE ROV Competition. You may not use these materials for commercial purposes without written permission from the MATE ROV Competition. Please click on the Creative Commons link above for license details.

<http://materovcompetition.org/>

Edits are highlighted in yellow.

January 16, 2024.

Pg. 15, 19, 20: Task 1. Due to safety concerns and the potential to damage the pool, the bullet point for manually returning the multi-function node to the surface, side of the pool has been removed. Points for that task have been added into the previous bullet point for connecting the recovery line to the bale.

OVERVIEW

From Technical to Teamwork, Problem-Solving, Creativity, and Critical Thinking: MATE Develops Skills for Success in the Workforce

As you prepare to develop and deploy technologies to monitor ocean conditions and understand ecosystems, make sure to find a moment to reflect on the skills that you are developing to allow you to tackle these tasks. These are the skills that you will take with you along your educational journey and pathway into the 2024 SCOUT CLASS

workplace.

They also happen to be the skills that are in high demand by employers around the globe. Machine learning, data analytics, AI, video marketing, critical thinking, creativity, collaboration, time management, and leadership – articles published by [LinkedIn](#) and [Forbes Magazine](#) highlight these technical and employability (aka “soft”) skills as the most “in-demand for the next 10 years” and, likely, beyond.

A number of these skills could be described as “entrepreneurial,” part of a skill set that also includes the ability to understand the breadth of business operations (from using data analytics to make informed financial decisions to researching and critiquing potential design solutions and producing content for media outreach); acknowledge your strengths (and weaknesses!); work as an integral part of a team; and apply technical knowledge and skills in new and creative ways. By developing a business acumen, a mindset for innovation and collaboration, and an understanding of how to take environmental, social, and governance (ESG) factors into consideration when making business decisions, you will be well prepared for the global workplace and ready to tackle today’s (and tomorrow’s!) challenges.

As you read through this manual you will see the following icons:*



These icons correspond to the employability (orange) and ROV-specific (green) knowledge and skills that you gain as you build your ROV and prepare for the competition and which of the various competition requirements – from the Product Demonstration to Engineering and Communication – help to develop each of these skills.

** These icons are from [Evaluate-Compete](#), which is designed to help give you a competitive edge in preparing for the competition and the workforce! High school and college teams are invited to participate in the project's pilot testing phase. Visit [Evaluate-Compete](#) for more information."*

THINK OF YOURSELVES AS ENTREPRENEURS

In this way, the MATE ROV Competition not only encourages you to reflect on the skills that you develop, but, for more than a decade, has also challenged you to think of yourself as an entrepreneur, embrace the skills that being one requires, and transform and organize your team into a start-up company. Use the following questions as a guide to assist you with this process:

- What is your company name?

- Who are its leaders, including the:
 - CEO (chief executive officer – the leader)
 - CFO (chief financial officer who oversees the budget and spending)
- Who manages Government and Regulatory Affairs (i.e. who’s in charge of reviewing the competition rules and making sure that they are understood and followed by everyone)?
- Who is responsible for research and development (aka R&D)?
- Who is responsible for system(s) engineering? Design integration? Testing? Operations?
- Who is responsible for fund-raising, marketing, and media outreach?
- Who is the company’s ESG research and engagement analyst?
- What other positions might you need? (Depending on your personnel resources, more than one person may fill more than one role.)
- What products and services do you provide?
- Beyond MATE, who are your potential clients?

“10 CHALLENGES - 10 YEARS - ONE OCEAN”

In short, the MATE ROV Competition’s philosophy is about student learning. It is about the knowledge and skills gained through participating in the competition and how that knowledge and those skills prepare you for your future career in the ocean STEM workforce – and [beyond](#).

As you contemplate your future education and career plans, the challenge presented to you today is how to apply your knowledge and skills to addressing the competition mission tasks so that we can effectively consider and respond to the question “how do we move from the ocean we have to the ocean we want?”

Again this year the MATE ROV Competition is highlighting the [United Nations Decade of Ocean Science for Sustainable Development](#) and aligning its mission tasks with the “10 Challenges for Collective Impact”. This 2024 MATE ROV Competition also continues to inspire ESG principles in order to do “good for good” for our ocean planet and global community. Again this MATE ROV Competition season the “client” is us – our global community of learners, inspired by the ocean, innovating and collaborating to address societal challenges. You are presented with a request for proposals (RFP), the specifics of which are included below.

PART 1: PRODUCT DEMONSTRATION



OVERVIEW

SCOUT class companies will take part in ONE product demonstration that consists of four distinct tasks:

TASK #1: Ocean Observing Initiative: Coastal Pioneer Array

2024 SCOUT CLASS

TASK #2: SMART Cables for Ocean Observing

TASK #3: From the Red Sea to Tennessee

TASK #4: MATE Floats!

NOTE: Regional competitions may not include all 4 tasks of the product demonstration; regional competitions may also give companies more than one attempt at the product demonstration. [Contact your regional coordinator or visit your regional contest's website](#) to determine what will take place at your regional competition. Regardless, the product demonstration score will be added to your [ENGINEERING & COMMUNICATION](#) and [SAFETY](#) scores to determine your total, overall score for the competition.

SCORING OVERVIEW

The competition consists of product demonstrations, engineering and communication, and safety with the following scoring breakdown:

- **Product Demonstrations**
 - 250 points (max), plus a time bonus
- **Engineering & Communication**
 - Technical documentation – 50 points (max)
 - Engineering presentations – 50 points (max)
 - Marketing displays – 50 points (max)
 - Company Spec Sheet – 20 points (max)
 - Corporate Responsibility – 20 points (max)
- **Safety** – 10 points (max)

TOTAL POINTS = 450

NOTE: Regional contests may not require all of the Engineering & Communications components or offer the opportunity to earn points for Corporate Responsibility. Contact [your regional coordinator or visit your regional contest's website](#) for more information.

TIME

The time that your company will have to complete the product demonstration will depend on your regional event. In general, the product demonstration time consists of a 3-minute set-up period, a 10-minute performance period, and a 2-minute demobilization period. Contact [your regional coordinator or visit your regional contest's website](#) to determine how your demonstration will be timed and how long you will have to set up, complete the tasks, demobilize, and exit the station.

At any time during the product demonstration you may pilot your ROV to the surface and remove it from the water for things such as buoyancy adjustments, payload changes, and troubleshooting. However, the product demonstration clock will NOT stop. The only time the clock will stop is if a judge determines that there is an issue that is beyond your control. Otherwise, the clock will only stop after all of the tasks are successfully

completed, the ROV has returned to the surface under its own power so that it touches the side of the pool, and a member of your company at the product demonstration station has physically touched the vehicle. Your ROV is not required to return to the surface between tasks.

TIME BONUS

Companies will receive a time bonus for each product demonstration run if you:

- 1) successfully complete the tasks,
- 2) return your ROV to the surface under its own power so that it touches the side of the pool, and
- 3) physically touch your vehicle before the product demonstration time ends.

How the time bonus is calculated will depend on your regional event. Contact your [regional coordinator](#) for more information.

CONTEXT & NEED

It's official – and we are still celebrating!

On July 1, 2023, MATE Inspiration for Innovation, along with the MATE ROV Competition, the SeaMATE Store, MATE professional development workshops, and instructional resources that support student learning, became part of the [Marine Technology Society \(MTS\)](#).

For MATE, it is a “homecoming;” while the MATE ROV Competition has evolved and expanded over the years, with its “alumni” embarking on careers in the ocean enterprise and other sectors, the mission to inspire and develop the next generation of ocean professionals remains at its core.

For MTS, it extends its reach to a much younger audience, one that is primed to connect with this international community of ocean scientists, engineers, practitioners, policy-makers, and educators – first as students then as early career ocean professionals then as society leaders.

We are also still celebrating the [United Nations Decade of Ocean Science for Sustainable Development](#). Via the MATE ROV Competition mission scenarios and tasks, we continue to highlight the Decade, embrace and inspire [ESG](#), and challenge our global community of learners to come together to inspire, innovate, and create solutions to the problems that impact us all.

By now you know that the United Nations (UN) proclaimed a [Decade of Ocean Science for Sustainable Development \(2021-2030\)](#) to support efforts to reverse the cycle of decline in ocean health and to gather the global community behind a common goal: creating improved conditions for sustainable use and development of our world ocean. More recently, the UN Decade of Ocean Science for Sustainable Development laid out “[10 Challenges for Collective Impact](#).” The four mission tasks of the 2024 MATE ROV Competition align with those challenges and, like the U.N., ask us to consider “how do we move from the ocean we have to the ocean we want?”

From expanding the Global Ocean Observing System to protecting and restoring ecosystems and biodiversity and unlocking ocean-based solutions to climate change, the 2024 competition mission tasks focus on

SOLUTIONS that include ocean observing assets for data collection, reimagining the utility of telecommunications cables, administering probiotics for diseased coral, identifying healthy habitats for lake sturgeon, and deploying GO-BGC floats to monitor ocean health. Again this year we embark on the 2024 season with optimism that together we can inspire, innovate, and create technology solutions to mitigate the impacts of climate change and pave the way to a sustainable future. And with ocean technologies and scientific data to support us, we are also optimistic that we can influence mindsets and guide communities to embrace and adapt practices for the good of us all.

If you have competed in the MATE ROV Competition over the last 3 years, it will come as no surprise that once again this MATE ROV Competition season the “client” is us – our global community of learners, inspired by the ocean, innovating and collaborating to address societal challenges. We acknowledge and embrace the UN’s “10 Challenges - 10 Years - One Ocean” and task our MATE competition community to design and build a remotely operated vehicle and the necessary sensors, tooling, and complementary technologies to monitor the health of the aquatic habitats of our Blue Planet, so that we can proactively and confidently answer the question “how do we move from the ocean we have to the ocean we want?”

REQUEST FOR PROPOSALS (RFP)

1. General

a. *OOI: Coastal Pioneer Array – Relocating ocean observing assets to “answer pressing science questions and gather data”*

Ocean Decade Challenges for collective impact:

#7 Expand the Global Ocean Observing System

The Ocean Observatories Initiative (OOI) is an ocean observing network that operates and maintains instruments and sensors that collect and deliver data to better understand the ocean and how it is changing as a result of natural and human-caused processes. Funded by the U.S. National Science Foundation (NSF), OOI connects researchers, educators, and the general public to a wide range of ocean instrumentation through its cyberinfrastructure, all without the need to go to sea. OOI includes more than 900 instruments, and the data collected by these instruments are freely available around the clock in near real-time.

OOI has three major categories of observatories that are linked together by instruments, infrastructure, and an information management system: global ocean arrays, regional cabled arrays, and coastal arrays. The data collected and delivered by these arrays are helping us to better understand ocean processes and create “products” that support commercial industries – and people’s livelihoods. For example, data collected by OOI’s Coastal Endurance Array and other ocean observing instrumentation helped to improve the forecasting of seasonal hypoxia (low oxygen) conditions in the Pacific Northwest, which allowed the Dungeness crab fishery to make educated management decisions, including where to place and when to harvest crab pots.

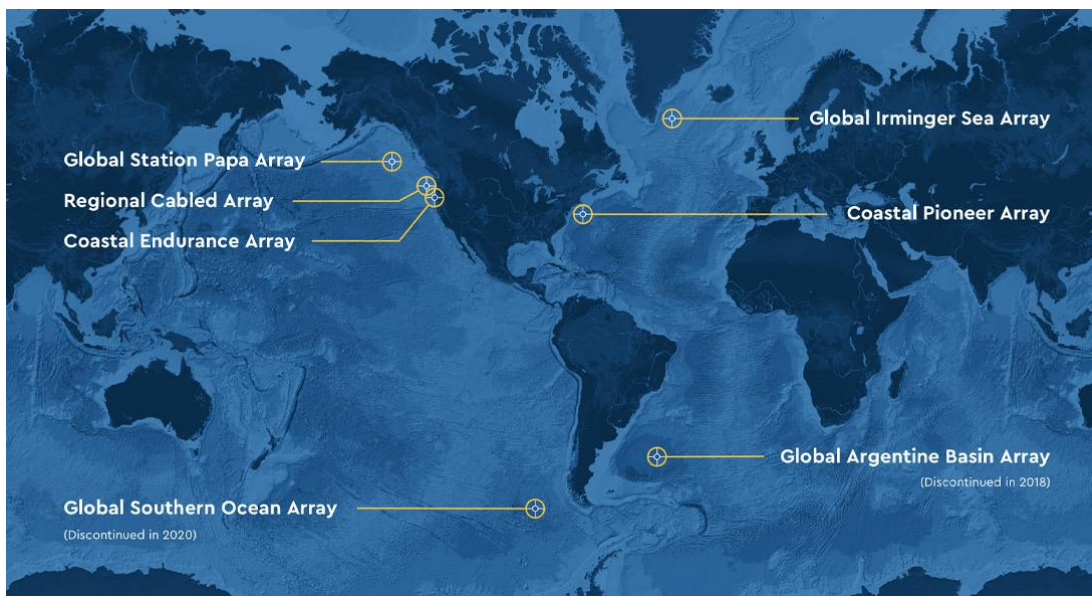

A map showing 7 of the 11 OOI arrays ([The Arrays - Ocean Observatories Initiative](#)).

One OOI observatory, the Coastal Pioneer Array, was designed to be re-locatable and suitable for moderate to high winds, waves, and currents on the continental shelf and upper slope. The Coastal Pioneer Array was installed in 2016 off the coast of New England, about 75 nautical miles south of Martha’s Vineyard. The array consisted of moored platforms, such as surface buoys, profiler moorings, and benthic multi-function nodes, and autonomous vehicles. It was maintained by the Woods Hole Oceanographic Institution (WHOI).

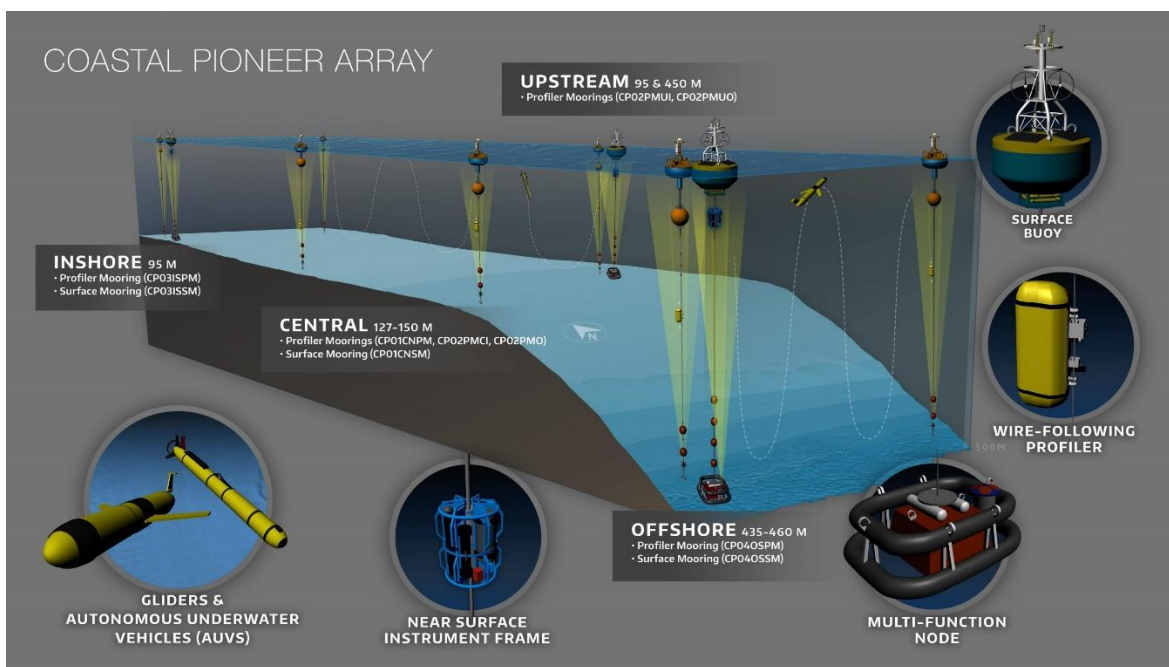

The instrumentation assets of the Coastal Pioneer Array ([Coastal Pioneer New England Shelf Array - Ocean Observatories Initiative](#)).

After a number of meetings with OOI partners and the broader scientific community, NSF proposed the Southern Mid-Atlantic Bight between Cape Hatteras and Norfolk Canyon off the coast of North Carolina as the next location for the Coastal Pioneer Array. Led by WHOI, planning for the relocation of the array started in June 2021.

Fast forward to December 2023 – the instrumentation and infrastructure of the Coastal Pioneer Array have been recovered and are currently out of the water and waiting for the necessary permits so that they can be installed along the Mid-Atlantic Bight. The target date for installation is April 2024.

Operations to remove the array’s instrumentation from the water included triggering acoustic releases to free recovery floats. Once on the surface, these floats and the lines connecting the floats to the multi-function nodes (and their anchor weights) are “hooked” by a surface support ship brought on board.

b. SMART Cables for Ocean Observing: “Undersea cables connect the planet – what if they could help save it?”

#7: Expand the Global Ocean Observing System

Science Monitoring And Reliable Telecommunications (SMART) Cables is a project that will equip transoceanic telecommunications cables with sensors to collect data on ocean health and monitor seismic activity. SMART Cables are just that – “smart” – in that they use transoceanic cable power and communications infrastructure to collect and transmit temperature, pressure, and seismic acceleration data – all of which are important environmental parameters of the deep ocean that are currently under-sampled. This data will not only provide valuable information about the state of the ocean, it will also benefit society by improving earthquake and tsunami early warning systems.

It is estimated that there are currently 1.4 million kilometers (or just under 1 million miles) of submarine cables crossing the ocean floor. These cables have a lifespan of approximately 25 years before they need to be replaced. The SMART concept is to integrate SMART Cable systems into replacement cables – or into new ones as the cable network expands, funded by billions of dollars of investments and driven by the world’s hunger for connectivity, especially in developing nations.

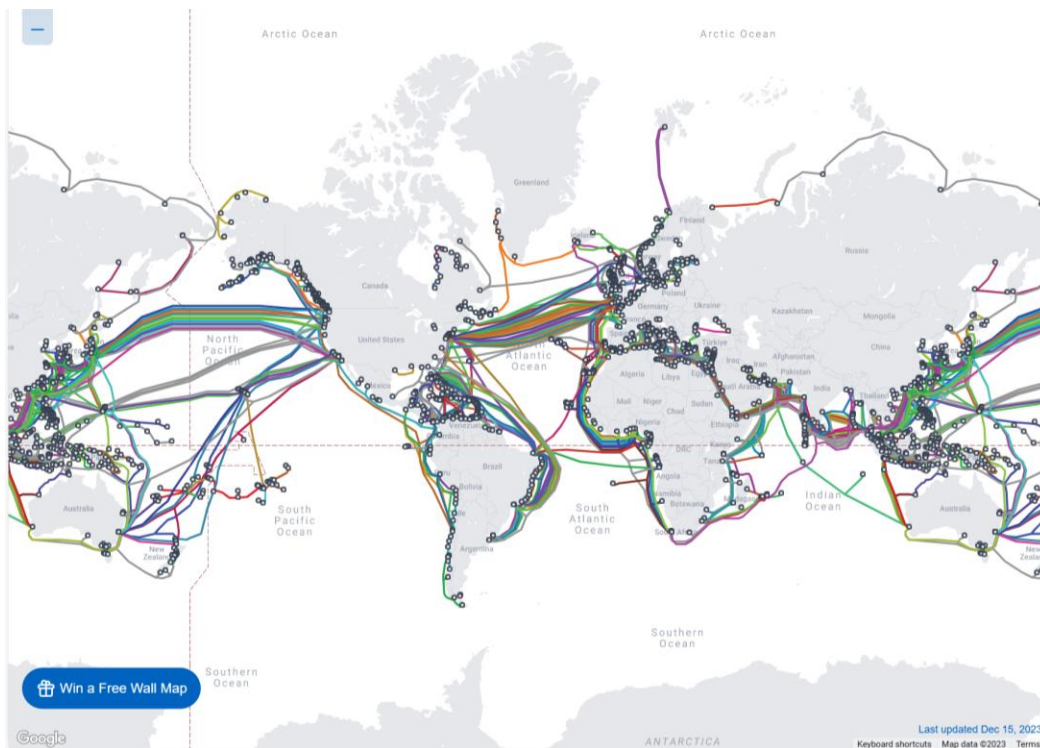

A snapshot of the current map of submarine telecommunication cables ([Submarine Cable Map](#)).

At the core of the “smart” innovation is the SMART Repeater, which houses the sensors that measure temperature, pressure, and seismic acceleration and includes a pass-through for the telecommunications cable. The telecommunications cable consists of copper wire, which the sensors tap into for power, and fiber optics for data transmission, which allow the sensor data to be shared in real-time.

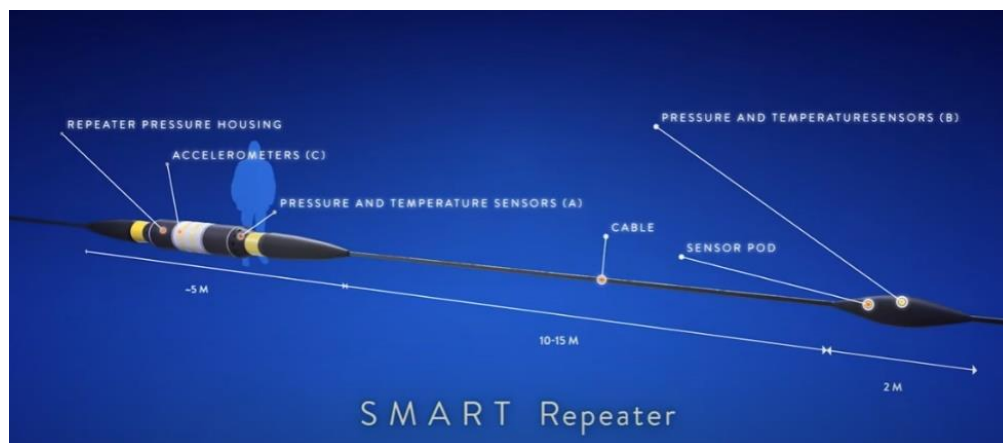

A SMART Cable Repeater ([SMART Cables for Ocean Observing](#)).

It has taken over 10 years from the initial idea to the point where a SMART Cable system is finally in development. The CAM (Continent - Azores - Madeira) cable ring off the coast of Portugal will be the first telecommunications/SMART Cable system. The existing CAM ring is up for replacement, so the plan is to take advantage of the replacement effort and incorporate a SMART Cable system, which will involve laying 3,700

kilometers of cable that includes 50 SMART repeaters (one every 74 km or so). The cable will travel from Lisbon to the Azores to Madeira and back to Lisbon, crossing seamounts, ridges, and other benthic features, along its route.

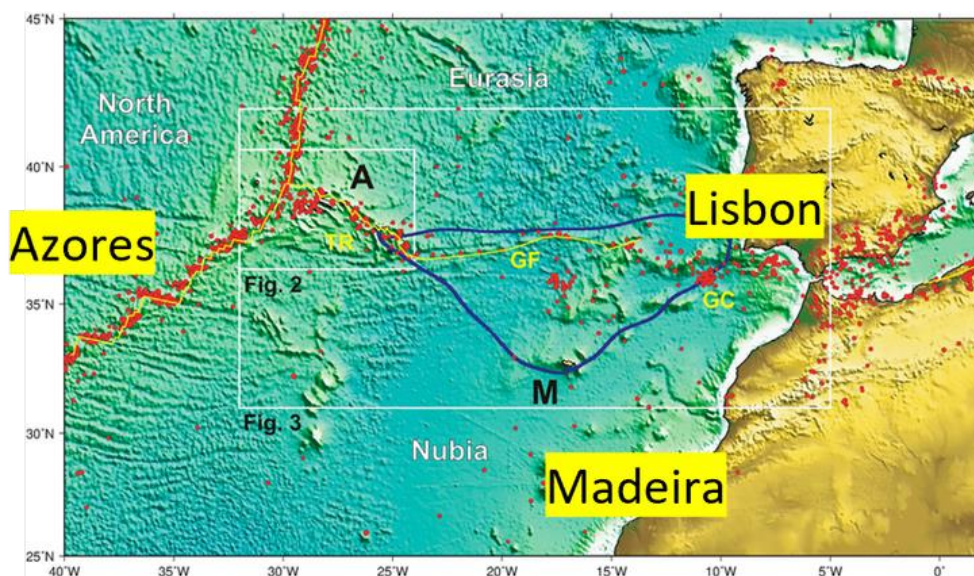

The CAM cable ring ([Atlantic CAM — SMART Cables for Ocean Observing](#)).

The Government of Portugal has approved the project and committed \$154 million Euros to fund it. The plan is to start deploying these cables in late 2025 or early 2026.

c. From the Red Sea to Tennessee: Understanding ecosystems and saving species
Ocean Decade Challenges for collective impact:
#2 Protect and restore ecosystems and biodiversity

A drop of water that begins its journey flowing along the Tennessee River in the mountains of the Appalachian Highlands will eventually make its way to the sea, where it could end up flowing over a coral reef in the Red Sea.

Like scientists at the [Smithsonian Marine Station \(SMS\)](#) featured in last year’s mission tasks, coral reef researchers at [King Abdullah University of Science and Technology’s Red Sea Research Center \(KAUST RSRC\)](#) are using probiotics to heal diseased coral and promote healthy coral ecosystems. These researchers focus on the idea that healthy organisms and ecosystems rely on healthy microbiomes. This “microbiome stewardship” takes advantage of the fact that microbes are key members of the “holobiont,” which is the collective term for a host organism and the variety of other species that live on, near, or within it, and that they connect all ecosystem entities, respond quickly to manipulation with immediate effects, and are easier to manipulate than macro-organisms.

To support their work on “rehabilitating marine microbiomes,” KAUST RSRC scientists, with help from engineers, technicians, and SCUBA divers, have established a permanent natural laboratory designed for coral

reef related research. This “[Coral Probiotics Village](#)” includes underwater pathways, such as Dr. Octopus Lane and Nemo Street, and study sites where probiotics are administered to coral via syringes as well as via an innovative “probiotics irrigation system.” In addition to delivering probiotics at scheduled intervals, the irrigation system also includes a CTD (conductivity, temperature, depth) and an Acoustic Doppler Current Profiler (ADCP) to capture these important environmental parameters.



KAUST RSRC’s probiotics irrigation system ([Roboto KAUST 2023.pdf - Google Drive](#))

More than 11,000 kilometers away from KAUST, researchers at the [Tennessee Aquarium](#) are using similar technologies to save another species – Lake Sturgeon. This prehistoric-looking fish has remained relatively unchanged since dinosaurs roamed the Earth. Once plentiful in the Tennessee River, Lake Sturgeon populations declined dramatically during the 1900s due to habitat loss caused by the construction of dams, pollution, and overfishing. Since 2000, the Tennessee Aquarium and its partners, which include state, federal, and global organizations such as the Tennessee Valley Authority, the U.S. Fish and Wildlife Service, and the World Wildlife Fund, have reintroduced nearly 250,000 Lake Sturgeon to their native waters in the Tennessee River system.

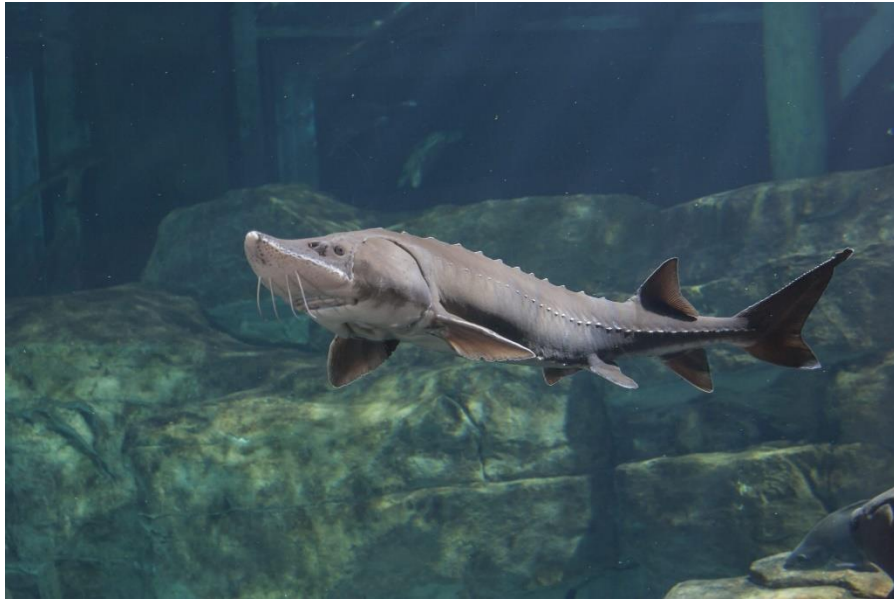

A Lake Sturgeon perusing its exhibit at the Tennessee Aquarium ([Lake Sturgeon · Tennessee Aquarium \(tnaqua.org\)](https://tnaqua.org))

Along with reintroduction, researchers are using observing technologies to learn more about Lake Sturgeon. For example, they have implanted tags into Lake Sturgeon to track their movements in the Tennessee River and deployed acoustic receivers in various locations to help identify potential spawning locations.

From the Red Sea to Tennessee is another reminder of the interconnectivity of our Blue Planet, how changes thousands of miles away from a coastline or thousands of miles away from the open seas can impact each other in either positive or negative ways, and how important observing technologies like CTDs, ADCPs, and acoustic receivers are to understanding ocean and inland aquatic environments and tracking environmental impacts.

Again this year, the UN Decade of the Ocean and the location of the MATE World Championship – along with the focus on observing technologies and the data they collect – provide the opportunity to challenge competitors around the globe to recognize that climate change is not limited to oceans and coastal communities; it impacts inland waterways and cities of “Mountain Empire” as well.

d. MATE Floats!

Ocean Decade Challenges for collective impact:

#5 Unlock ocean-based solutions to climate change

The goal of the [National Science Foundation \(NSF\)-funded GO-BGC Project](#) is to build a global network of chemical and biological sensors that will monitor ocean health. Scientists, engineers, and technicians from multiple organizations are using NSF grant funds to build and deploy 500 robotic ocean-monitoring floats around the globe. The temperature, depth, and bio-geochemical information that these floats collect will add

significantly to the repository of data needed to better understand ocean processes and predict the consequences of climate change. As of December 2023, nearly 150 GO-BGC floats have been deployed throughout the global ocean.

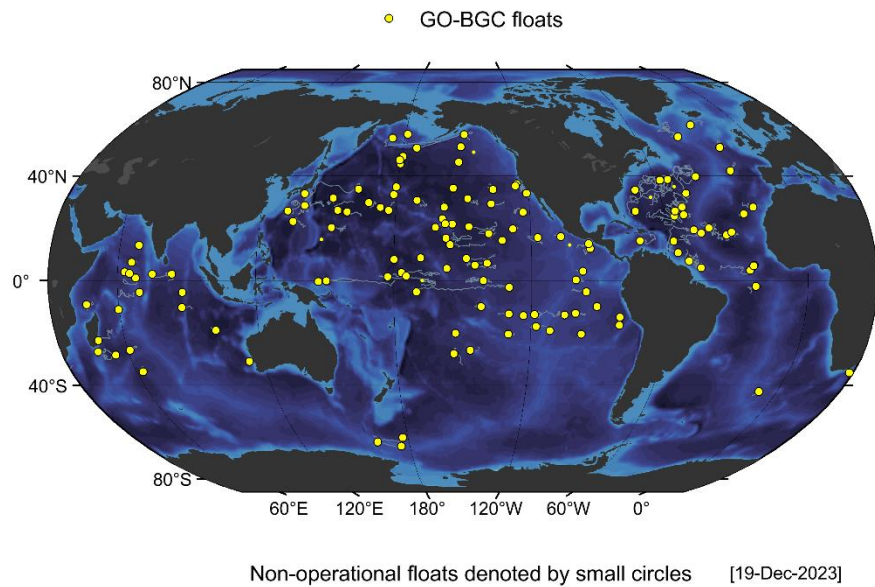

GO-BGC Float locations as of December 19, 2023 ([Array Status | GO-BGC](#)).

These 150 GO-BGC floats joined a larger network of vertical profiling floats that have been circulating the world ocean for more than 20 years. Named after the ship made famous by Jason of Greek mythology, the [Argo float program](#) is an international program that involves 30+ countries. Since 1990, the Argo program has deployed nearly 4,000 floats to collect temperature and salinity data and make this data available to the global community of researchers, transforming the way information about the ocean is gathered and shared. GO-BGC floats are essentially the next generation of Argo floats, representing a technological evolution in sensor technologies with the development and addition of bio-geochemical sensors – and, most importantly, making the data that these sensors collect part of the repository of information available to the broader science community.

The MATE ROV Competition’s main focus is on engineering ROVs. However, the GO-BGC project provides an opportunity to challenge our competitors to design and build another type of underwater technology, one that contributes to ocean observations and research that is needed to better understand the impact of climate change.



Readying a GO-BGC float for deployment ([GO-BGC | Global Ocean Biogeochemistry Array](#))

THIS IS WHERE YOUR MISSION BEGINS.

a. Mission Scope and Purpose

This and the following sections contain the technical specifications and requirements for ROV services needed to support the **OBSERVING OUR OCEANS: UNDERSTANDING OUR WORLD AND CREATING OUR FUTURE**. In 2024, ROV services include:

1) TASK 1: OOI: Coastal Pioneer Array – Relocating ocean observing assets to “answer pressing science questions and gather data”

Ocean Decade Challenges for collective impact:

#7 Expand the Global Ocean Observing System

- “Trigger” the release of the multi-function node’s recovery float
- Pull pin to release the recovery float to the surface
- Return the recovery float to the surface, side of the pool
- Connect a recovery line to the bale on the multi-function node for ship recovery
- **Manually return the multi-function node to the surface, side of the pool**

2) TASK 2: SMART Cables for Ocean Observing: “Undersea cables connect the planet – what if they could help save it?”

Ocean Decade Challenges for collective impact:

#7 Expand the Global Ocean Observing System

- Deploy SMART cable through two waypoints
- Place SMART repeater in the designated area
- Return SMART cable end to the surface, side of the pool
- Retrieve a power connector from an AUV docking station
- Install the power connector

3) TASK 3: From the Red Sea to Tennessee: *Understanding ecosystems and saving species* Ocean Decade Challenges for collective impact:

#2 Protect and Restore Ecosystems and Biodiversity

Smart Reefs

- Place a probiotic irrigation system near coral head
- Deploy a probiotic sprinkler on coral head
- Activate the irrigation system
- Transplant corals to the restoration area

Inland Lakes and Waterways – Sturgeon Restoration

- Recover an acoustic receiver to retrieve its data to determine the location of sturgeon spawning grounds
- Create a graph of sturgeon locations from acoustic receiver data
- Determine the potential spawning site
- Place an ADCP at the potential spawning site
- Recover a sediment sample from the potential spawning site

4) TASK 4: *MATE Floats!*

UN Sustainable Development Goal:

#13 Climate Action

- Prior to the competition, design and construct an operational vertical profiling float with a temperature sensor
- Deploy the float in the designated area
- Float completes a vertical profile
- Float collects temperature data
- Data is graphed as temperature versus depth

1. Specifications

See the specific tasks described below as well as the [VEHICLE DESIGN & BUILDING SPECIFICATIONS](#) and [COMPETITION RULES](#) sections.

2. Maintenance and Technical Support

The company will guarantee the ROV for the duration of the product demonstrations. Repair or replacement will be at the company's expense. The company will provide at least one day of technical support to deal with any issues.

3. Shipping and Storage

Delivery of the ROV will be no later than the date of the nearest regional contest.

4. Evaluation Criteria

- a. Technical documentation
- b. Engineering presentation
- c. Marketing display
- d. Company spec sheet
- e. Product demonstration
- f. Safety

5. References

a. GENERAL

- [United Nations Decade of Ocean Science for Sustainable Development](#)
- [17 UN Sustainable Development Goals](#)
- [10 Challenges - Ocean Decade](#)
- [A Hotter Future Is Certain, Climate Panel Warns. But How Hot Is Up to Us](#)
- [ESG \(environmental, social and governance\)](#)
- [What is blue carbon? - Great Barrier Reef Foundation](#)

b. TASK 1: OOI: Coastal Pioneer Array – Relocating ocean observing assets to “answer pressing science questions and gather data”

- [Ocean Observatories Initiative – A new era of oceanography](#)
- [Coastal Pioneer New England Shelf Array – Ocean Observatories Initiative](#)
- [CP04OSPM – Ocean Observatories Initiative](#)
- [OOI Coastal & Global Scale Nodes](#)
- [The Ocean Observatories Initiative](#)
- [Scientific rationale and conceptual design of a process-oriented shelfbreak observatory: the OOI Pioneer Array](#)
- [Coastal Surface Mooring Developments for the Ocean Observatories](#)
- [OOI Data Explorer](#)
- [Forecasting Hypoxia to Support the Dungeness Crab Fishery - Ocean Observatories Initiative](#)

c. TASK 2: SMART Cables for Ocean Observing: “Undersea cables connect the planet – what if they could help save it?”

- [SMART Cables for Ocean Observing](#)
- [Science Monitoring and Reliable Telecommunications \(SMART\)](#)
- [SMART Cables for Observing the Global Ocean: Science and Implementation](#)

- [SMART Subsea Cables for Observing the Ocean and Earth Presentation](#)
- [Marine Technology Society Journal: SMART Subsea Cables for Observing the Ocean and Earth](#)
- [The Seamounts of the Goringe Bank \(oceana.org\)](#)
- [Charting the Depths: The World of Subsea Cables \(visualcapitalist.com\)](#)

d. TASK 3: From the Red Sea to Tennessee: Understanding ecosystems and saving species

- [allencoralatlas](#)
- [KAUST Reefscape restoration initiative at Shushah](#)
- [Robotic Customized Medicine for Corals](#)
- [Smart Reef and Coastal Sensing Network](#)
- [Holobiont: Definition, Explanation And Examples \(scienceabc.com\)](#)
- [Lake Sturgeon · Tennessee Aquarium](#)
- [Ecoacoustic Monitoring of Lake Sturgeon](#)
- [Sound Production of Spawning Lake Sturgeon](#)
- [Sturgeon Bend](#)

e. TASK 4: MATE Floats!

- [GO-BGC | Global Ocean Biogeochemistry Array](#)
- [Expanding Fleet of Autonomous Floating Robots Targets Deeper Understanding of Global Ocean Dynamics](#)
- [2021 MATE Floats! | MATE ROV Competition Website](#)
- [Adopt-a-Float Newsletters | GO-BGC](#)
- [Argo: A window into the ocean \(arcgis.com\)](#)
- [Argo \(ucsd.edu\)](#)

IMPORTANT NOTE: Questions about production demonstrations and design and building specifications should be sent to the [Competition Technical Manager](#). Question, answers, and official rulings will be posted on the MATE ROV Competition [Q&A and Official Ruling Document](#). This allows all companies to see the questions and answers and helps to avoid duplicate questions. That said, please make sure that your question(s) has not already been asked – and answered – before emailing. It is up to the companies to read, comprehend, and comply with ALL rulings posted on the site.

SIZE RESTRICTIONS

None. SCOUT class companies are not restricted on the size of their vehicle. Companies must be able to transport the vehicle and associated equipment to the product demonstration station and to the engineering presentation area by hand. ROV systems must be capable of being safely hand launched.

PRODUCT DEMONSTRATION

TASK 1: OOI: Coastal Pioneer Array – Relocating ocean observing assets to “answer pressing science question and gather data”

This task involves the following steps:

1.1 Release the multi-function node

- “Trigger” the release of the multi-function node’s recovery float – 10 points
- Pull a pin to release the failed recovery float to the surface – 10 points
- Return the failed recovery float to the surface, side of the pool – 5 points
- Connect a recovery line to the bale on the multi-function node for manual recovery – 15 points
- Manually return the multi-function node to the surface, side of the pool – 5 points

Total points = 40 points

Product Demonstration Notes:

Task 1.1 Release the multi-function node

The multi-function node will be located on the bottom of the pool at the start of the product demonstration. The multi-function node will consist of a [plastic milk crate](#), 3-inch pipe holding the 2-inch pipe recovery float, and ½-inch PVC pipe framework. Companies must first simulate “triggering” an acoustic release by pulling a pin. The pin will be constructed from ½-inch PVC pipe.

Companies will receive 10 points for successfully pulling the pin to release the multi-function node’s recovery float. Successfully pulling the pin is defined as the pin no longer in contact with the ½-inch PVC framework of the multi-function node. The pin is not considered debris and may be left in the pool at the end of product demonstration time.

Once the pin is pulled, the recovery float will deploy. For this product demonstration task, the recovery float will not fully deploy; the deployment will be a failure. The recovery float will not rise all the way to the surface; the float’s rope will be “tangled” causing the float to remain in mid water. “Tangled” will be simulated by the shortened rope that is not long enough for the recovery float to reach the surface.

When the recovery float rises partially to the surface, a manual release pin will be revealed. This pin will be constructed from ½-inch PVC pipe and will secure a loop at the bottom end of the float’s rope. Companies will receive 10 points for successfully releasing the failed recovery float to the surface by pulling the pin. Successfully pulling the pin is defined as the pin no longer in contact with the milk crate and the failed recovery float rising to the surface. The pin is not considered debris and may be left in the pool at the end of product demonstration time.

Once released to the surface, companies must return the recovery float to the surface, side of the pool. Companies will receive 5 points for successfully returning the recovery float to the surface, side of the pool. Successfully returning the float is defined as the float out of the pool and placed on the pool deck.

Companies must connect a recovery line to the bale on the multi-function node. The bale will be constructed from ½-inch PVC pipe with Velcro hooks on the underside. MATE will provide a recovery line and hook. The hook will be constructed from ½-inch PVC pipe with Velcro loops covering the hook. Companies will receive 15 points when the recovery line is successfully attached to the bale on the multi-function node. Successfully attaching the recovery line is defined as the hook no longer in contact with the ROV and a Velcro-to-Velcro connection made to the bale on the multi-function node.

Once a recovery line has been secured to the multi-function node, companies may manually recover the multi-function node. Company members may pull the recovery line by hand to retrieve the multi-function node to the surface, side of the pool. Companies will receive 5 points for successfully recovering the multi-function node. Successfully returning the multi-function node is defined as the multi-function node removed from the pool and placed on the pool deck.

TASK 2: SMART Cables for Ocean Observing: “Undersea cables connect the planet – what if they could help save it?”

This task involves the following steps:

2.1 Deploy SMART cable

- **Deploy SMART cable through two waypoints located on the bottom of the seafloor – 5 points each, 10 points total**
- **Place the SMART repeater in the designated area – 10 points**
- **Return the end of the cable to surface, side of the pool – 5 points**
- **Connect the AUV docking station to the SMART cable repeater**
 - **Retrieve the power connector from the AUV docking station – 10 points**
 - **Install the power connector – 15 points**

Total points = 50 points

Product Demonstration Notes:

Task 2.1 Deploy the SMART cable

The SMART cable with one SMART repeater will be located on the surface, side of the pool at the start of the product demonstration. The SMART cable will be constructed from wire with one SMART repeater, which will be constructed from 1 ½-inch PVC pipe attached to the wire. Companies must deploy the SMART cable through two waypoints. Waypoints will be constructed from ½-inch PVC pipe. Companies will receive 5 points for successfully deploying the cable through each waypoint on the seafloor, 10 points total. Successfully deploying the cable through a waypoint is defined as the wire inside two PVC posts of the waypoint.

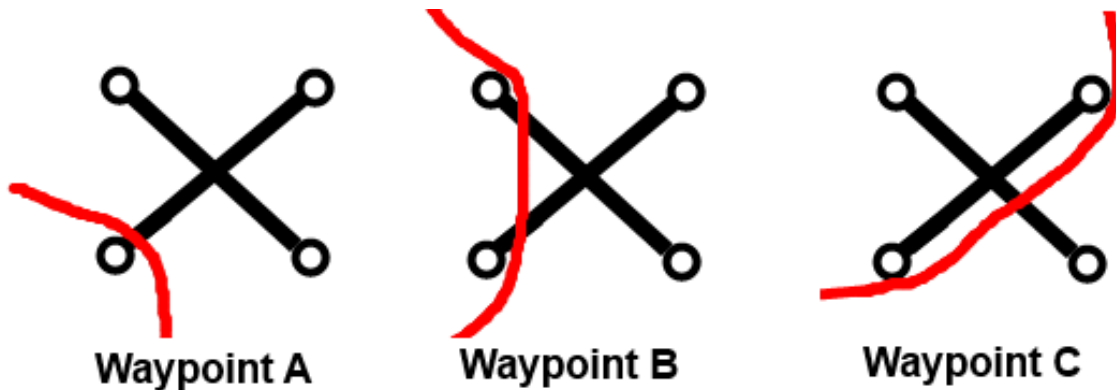

Depiction of successful and unsuccessful cable lying through waypoints. Waypoint A is an unsuccessful cable lay, as the cable is inside one vertical post only. Waypoint B is a successful cable lay, as the cable is inside two vertical posts. Waypoint C is an unsuccessful cable lay, as the cable is only inside one vertical post (the lower right post only).

The wire simulating the SMART Cable will run through a SMART repeater. The SMART repeater will be constructed from 1 ½-inch PVC pipe and end caps. A [#6 screw hook](#) will act as a carrying mechanism for the SMART repeater. Companies must place the SMART repeater into a designated area constructed of ½-inch PVC pipe painted blue. Companies will receive 10 points for successfully placing the SMART repeater in the designated area. Successfully placing the SMART repeater in the designated area is defined as the 1 ½-inch PVC pipe of the repeater no longer in contact with the ROV and completely inside the designated area.

The SMART repeater will weigh less than 5 Newtons in water.

Once the SMART cable is deployed through both waypoints and the SMART repeater is placed in the designated area, the end of the cable must be returned to the surface side of the pool. Companies will receive 5 points for successfully returning the cable end to the surface, side of the pool. Successfully returning the cable end is defined as the wire successfully deployed through both waypoints, the SMART repeater successfully placed in the designated area, and both ends of the wire on the surface, side of the pool.

Once the SMART repeater has been successfully placed in the designated area, companies must connect a nearby AUV docking station to the SMART repeater. The AUV docking station will be constructed from ½-inch PVC pipe. The connector will be located on a corrugated plastic sheet platform on the AUV docking station. The connector will be constructed from ½-inch PVC pipe. A [#6 screw hook](#) will act as a carrying mechanism for the connector. A [rope](#) will be coiled on the platform with the connector and attach the connector to the AUV docking station. Companies will receive 10 points for successfully retrieving the power connector from the AUV docking station. Successfully retrieving the connector is defined as the connector under control of the ROV and no longer touching the platform or the AUV docking station.

The AUV docking station connector will weigh less than 5 Newtons in water.

Once the connector has been retrieved from the AUV docking station, it must be installed into the SMART repeater. The SMART repeater will have two sections of Velcro loops, each 5 cm wide, on either side of the #6 screw hook. The attachment end of the connector will be covered with Velcro hooks. Companies will receive 15 points when the connector is successfully installed into the SMART repeater. Successfully installing the connector is defined as the connector no longer in contact with the ROV and the connector making a Velcro-to-Velcro stick with the SMART repeater.

Note that in order to connect the AUV docking station, the SMART repeater MUST be successfully placed in the designated area.

TASK 3: From the Red Sea to Tennessee: Understanding ecosystems and saving species

This task involves the following steps:

Smart Reefs

3.1 Probiotics 2

- **Place a probiotic irrigation system in the designated location – 10 points**
- **Deploy the probiotic sprinkler on coral head – 10 points**
- **Activate the irrigation system – 10 points**

3.2 Coral Restoration

- **Transplant branching coral – 10 points**
- **Transplant brain coral – 10 points**

Tennessee Lakes and Rivers

3.3 Determine the location of sturgeon spawning grounds

- **Recover an acoustic receiver – 10 points**
- **Determine the location of a potential spawning site**
 - **Create a graph of sturgeon locations from the acoustic receiver data – 15 points**
 - **Determine the potential spawning site – 5 points**
- **Characterize the habitat at potential spawning site**
 - **Place an ADCP – 10 points**
 - **Recover a sediment sample – 10 points**

Total points = 100 points

Product Demonstration Notes:

Task 3.1 Probiotics 2

Companies must place the probiotic irrigation system in the designated location. The probiotic irrigation system will be located on the surface, side of the pool at the start of the product demonstration. The irrigation system will be constructed from ½-inch, 1-inch, and 2-inch PVC pipe. A [#310 U-bolt](#) will act as a carrying mechanism for the irrigation system. A length of [vinyl tubing](#) covered in red tape, the probiotic sprinkler, will be attached to and hang from a [#6 screw hook](#) on the irrigation system. The designated location will be

constructed from ½-inch PVC pipe painted yellow. Companies must place the irrigation system in the designated location. Companies will receive 10 points for successfully placing the irrigation system in the designated location. Successfully placing the irrigation system in the designated location is defined as the irrigation system no longer in contact with the ROV and completely within the PVC pipe of the designated location.

The irrigation system will weigh less than 5 Newtons in water.

Companies must place the probiotic sprinkler over an elkhorn coral within the coral restoration area. The coral restoration area will be constructed of ½-inch PVC pipe with corrugated plastic sheeting attached to the top. An elkhorn coral, painted yellow, will be located in the center of the coral restoration area. Companies must remove the probiotic sprinkler from the hook on the irrigation system and place the sprinkler over the branching coral. Companies will receive 10 points when the probiotic sprinkler is successfully placed over the coral head. Successfully placing the sprinkler is defined as the sprinkler no longer in contact with the ROV and completely over all branches of the coral head.

Once the probiotic sprinkler is placed over the elkhorn coral head, companies must activate the irrigation system. A ½-inch PVC pipe handle will be incorporated into the ½-inch PVC pipe of the irrigation system; one length of PVC pipe will be painted red. Companies must turn the handle 360° to activate the irrigation system. Companies will receive 10 points for successfully activating the irrigation system. Successfully activating the irrigation system is defined as showing the station judge on a video screen that the handle is turned 360°.

Note that companies must successfully place the probiotic sprinkler over the coral head before activating the irrigation system.

Task 3.2 Coral Restoration

Companies must transplant one branching coral and one brain coral from the surface to the coral restoration area. Both the branching coral and the brain coral will be located on the surface, side of the pool at the start of the product demonstration run. The branching coral will be constructed from ½-inch PVC pipe painted pink with a rope carrying mechanism attached. The brain coral will be constructed from a [plastic bowl](#) with a rope carrying mechanism attached.

Companies must transplant the branching coral into the holder on the coral restoration area. A section of 2-inch PVC pipe with a [3-inch to 2-inch reducer](#) will rise vertically from the coral restoration area. Companies must insert the branching coral into the 3-inch reducer. Companies will receive 10 points for successfully transplanting the branching coral fragment. Successfully transplanting the coral is defined as the branching coral positioned inside the vertical 3-inch reducer.

Companies must also transplant brain coral into the restoration area. The brain coral will have Velcro loops on the underside of the bowl. The restoration area will have a 15 cm square area of Velcro hooks on the horizontal corrugated plastic sheet surface. Companies must transplant the brain coral from the surface to the restoration area. Companies that successfully transplant the brain coral will receive 10 points. Successfully

transplanting the brain coral is defined as the vehicle, under control of the pilot, placing the brain coral on the Velcro square. Any portion of the bottom of the brain coral may be touching any portion of the Velcro square.

Both the branching coral and the brain coral must remain successfully transplanted into the coral restoration area for the entire product demonstration run. If either the branching or brain coral is displaced from the reducer or Velcro at any time during the product demonstration run, the company will not receive points for successfully transplanting the coral. If a coral is displaced from the coral restoration area, companies may attempt to transplant the coral again.

Tennessee Lakes and Rivers

Task 3.4 Determine the location of sturgeon spawning grounds

Three acoustic receivers will be located in three different potential spawning locations on the bottom. Companies must recover one acoustic receiver. The acoustic receivers will be constructed from 3/4-inch and 1/2-inch PVC pipe. Companies will receive 10 points when they successfully recover one acoustic receiver. Successfully recovering one acoustic receiver is defined as the acoustic receiver out of the water and placed on the pool deck.

The acoustic receiver will weigh less than 5 Newtons in water.

Once the acoustic receiver has been recovered, companies will receive a table that contains data on sturgeon spawning sounds (also known as “sturgeon thunder”) from the mission station judge. NOTE: If the mission station judge does not immediately provide this table, companies should request it. This table will include data from all three acoustic receivers collected over 8 days. The data will be printed on a laminated sheet.

Companies must use this data to create a graph of the number of sturgeon in each location over the course of 8 days. Companies will receive 15 points for successfully creating a graph of the data. Successfully creating a graph is defined as showing the station judge a graph with all 24 data points plotted as 3 receivers, each containing 8 data points. How companies graph the data is up to them, i.e., it can be done by hand or using a laptop, but the graph should logically show sturgeon numbers from all three acoustic receivers. The graph must be titled and must have both axes labeled (# of sturgeon, day #).

Day	# of sturgeon							
	1	2	3	4	5	6	7	8
Receiver 1	3	3	0	0	1	1	1	1
Receiver 2	2	3	0	1	1	3	2	4
Receiver 3	3	2	8	10	11	2	3	3

A table showing the sturgeon data recovered from the acoustic receivers. The data represents the number of sturgeon detected per day at each acoustic receiver.

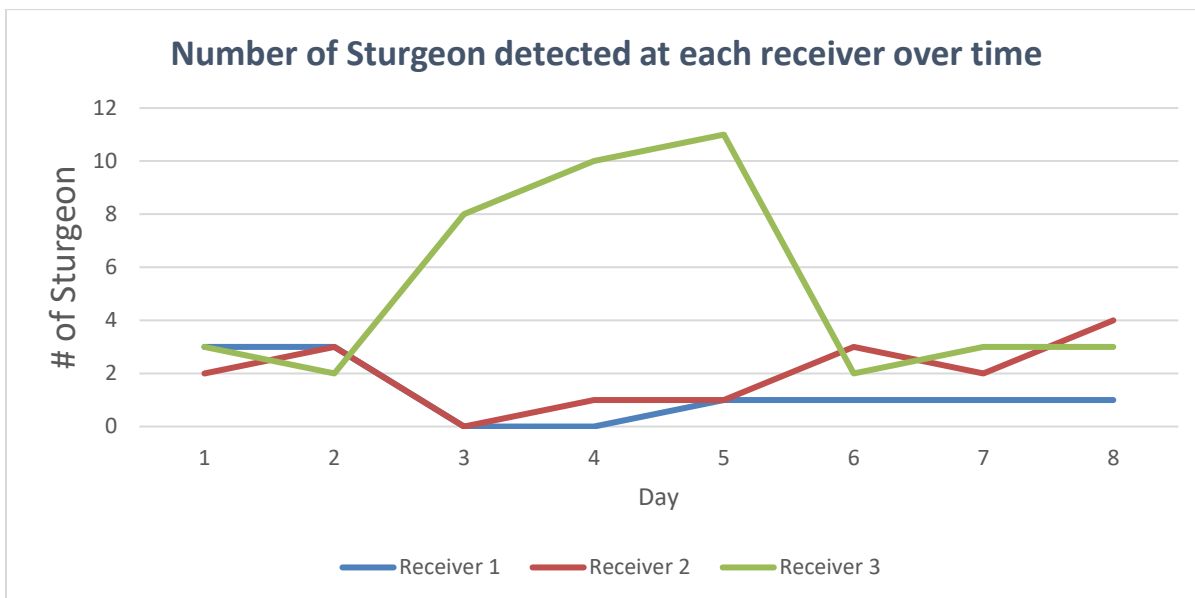
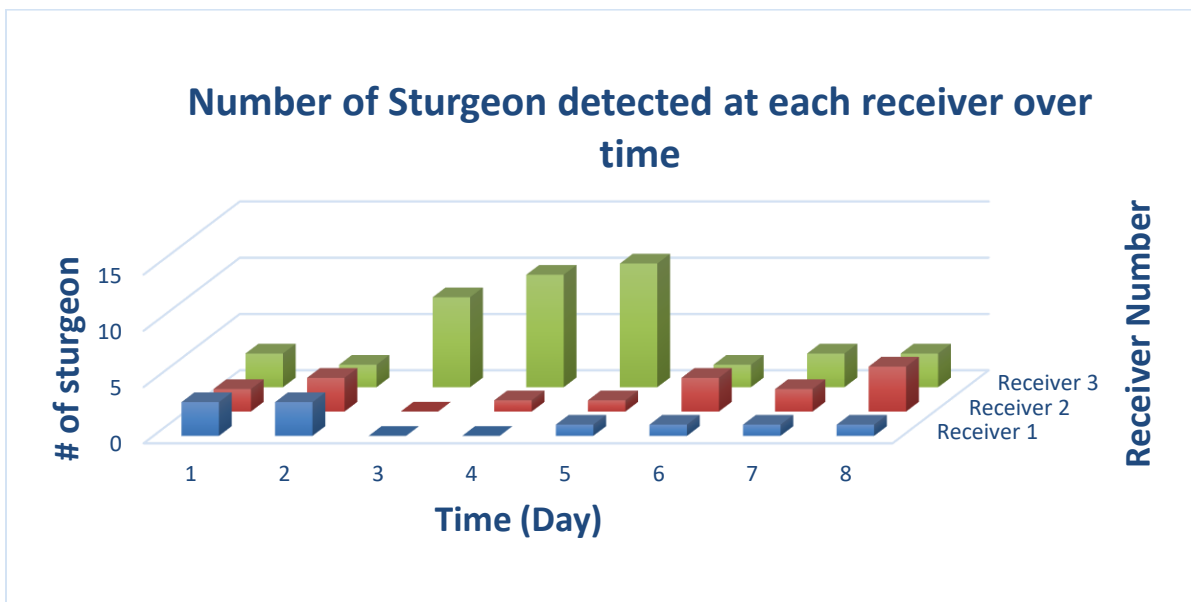

Two graphs displaying sturgeon numbers for each day at three different acoustic receivers. Either graph would successfully display the sturgeon locations from the acoustic receiver data.

Companies must then use their graph to determine the potential sturgeon spawning site, which is the location that has the highest number of sturgeon over a three-day period. Companies will receive 5 points when they successfully determine the potential spawning site. Successfully determining the potential spawning site is defined as using the graph to communicate to the station judge the highest concentration of sturgeon over a 3-day period. Companies must use the graph, and not the raw data, to determine the potential spawning location. For example, from either of the example graphs above, companies would select the Receiver 3 location as the spawning site, identifying Day 3 through 5 as the highest number of sturgeon, and communicate this to the station judge while showing the judge their graph.

Companies must place an [Acoustic Doppler Current Profiler](#) (ADCP) in the designated location at the potential spawning site. Note: Although the data has three potential sites for the sturgeon spawning, there will only be one designated location. The designated location will be constructed of ½-inch PVC pipe painted orange. The ADCP will be constructed of ½-inch PVC and 2-inch PVC pipe and will be available at the surface, side of the pool at the start of the product demonstration run. A rope attached to the top of the ADCP will act as a carrying mechanism. Companies must place the ADCP in the designated location. Companies will receive 10 points for successfully placing the ADCP in the designated location. Successfully placing the ADCP in the designated location is defined as the ADCP no longer in contact with the ROV and the ½-inch base completely inside the designated area.

Companies must collect a sediment sample at the potential spawning site. The sediment will be simulated by [Mexican Beach Pebbles](#), which are rounded black rocks approximately 1-inch to 2-inch in maximum length. The Mexican Beach Pebbles will be located in a ½-inch PVC rectangle adjacent and attached to the designated area for the ADCP. There will be at least five rocks, possibly more, in the rectangle. Each rock will have a 2 cm x 2 cm square of Velcro hooks attached to both sides. Companies must recover one rock to the surface, side of the pool. Companies will receive 10 points for successfully recovering the sediment sample. Successfully recovering the sediment sample is defined as at least one rock being returned to the surface, side of the pool and placed on the pool deck.

NOTE: Companies do not need to determine the potential spawning site before placing the ADCP and collecting the sediment sample. These tasks are independent of determining the potential spawning location.

TASK 4: *MATE Floats!*

MATE Floats! 2024 is inspired by the National Science Foundation (NSF)-funded GO-BGC Project. The goal of GO-BGC is to help build a global network of profiling floats with chemical and biological sensors to monitor circulation, chemistry, biology, and overall ocean health. Scientists, engineers, and technicians are using NSF grant funds to build and deploy 500 robotic ocean-monitoring floats around the globe.

This task involves the following steps:

Design and build an operational vertical profiling float

- **Prior to the competition, design and construct a vertical profiling float with a temperature sensor – up to 10 points**
 - **Design and construct a vertical profiling float – 5 points**
 - **Include a temperature sensor – 5 points**
- **Deploy the float into a designated area – 5 points**
- **Float completes a vertical profile – 15 points**
- **Float collects temperature data from four points – up to 20 points**
 - **Air (prior to being deployed) within 4°C – 5 points**
 - **Surface within 4°C – 5 points**

- Mid-water within 4°C – 5 points
- Bottom within 4°C – 5 points
- Graph water temperature versus depth – 10 points

OR

Company does not design and construct a vertical profiling float or the float does not contain a temperature sensor.

- MATE-provided data is used to graph water temperature versus depth – 10 points

Total points = 60 points

Product Demonstration Notes:

Prior to the competition, SCOUT companies must build a float capable of completing a vertical profile (i.e., traveling from the surface to the bottom and back to the surface) and collecting data during the profile.

The vertical profiling float:

- May use a motor and propeller to travel from the surface to the bottom and back. Alternatively, the float may use other means to go up and down, such as a [buoyancy engine](#).
- Propellers must be enclosed inside the frame of the float or shrouded. The propeller should not be able to touch any surface of the pool. Floats with propellers protruding outside the framework will not pass safety inspection and cannot be used.
- Must operate independently of the ROV. The ROV may carry the float to the designated area, but the float must go down and up independently of the ROV (on its own).
- May be operated by a pilot. This pilot can be the same person who pilots the ROV or a different pilot.
- Must be less than 50 centimeters in overall height. The float may not have a diameter/length/width greater than 12 cm.
- MUST operate as a non-ROV device. See below for additional information on powering non-ROV devices.

Companies will receive 5 points for successfully designing and constructing a vertical profiling float.

Successfully designing and constructing a float is defined as bringing the profiling float to the mission station and explaining to the judge how it operates (how it moves up and down in the water column). Companies will receive 5 points for successfully incorporating a temperature sensor on their profiling float. Successfully incorporating a temperature sensor is defined as showing the station judge the temperature sensor on your float.

Companies must deploy their float in a designated location. The designated location is defined as anywhere beyond a green mark set 1 meter out in the pool. Companies will receive 5 points when they successfully deploy their float. Successfully deploying the float is defined as the float no longer in contact with the ROV, floating on the surface, and beyond the green mark 1 meter away from the side of the pool. If the float is

released before reaching the designated location, companies are permitted to retrieve the float and reposition it in the designated location.

Once released, the float should attempt to complete a vertical profile. A vertical profile is defined as any part of the float on or above the surface, descending in the water column until any part of the float touches the bottom, then ascending to and breaking the surface once again. Companies will receive 15 points for successfully completing a vertical profile. Successfully completing a vertical profile is the float starting on the surface, descending to and touching the bottom of the pool, then ascending to the surface again. Companies must complete an entire vertical profile, surface to bottom to surface, to receive points.

Companies must use the temperature sensor on their float to record four temperature measurements. One measurement must be recorded in the air. This measurement must be taken during the mission run before the float is deployed into the water by the ROV. Note that it cannot be taken during the set-up time. A second temperature measurement must be recorded at the surface. The temperature sensor must be underwater, but some portion of the float must be at the surface of the water. A third temperature measurement must be recorded in the midwater. No part of the float should be on or above the surface, no part of the float should be touching bottom. The float does not need to stop in the midwater in order to take the measurement. A sensor providing continuous temperature readings can be used, and a temperature reading recorded when the moving float reaches the midwater. A fourth temperature measurement should be recorded from the bottom of the pool. Some portion of the float must be touching the bottom of the pool.

Companies will receive 5 points for successfully recording each measurement, up to 20 points. Successfully recording a temperature measurement is defined as showing the station judge your temperature reading and recording that temperature at the mission station. Companies may record the temperatures by hand on paper or enter them into a computer or other device. MATE will not provide paper or a device for recording.

The accuracy of the temperature measurement must be within 4° Celsius of the true temperature. Station judges will have a temperature sensor that will measure the temperature of the pool and the air. Companies can compare their temperature sensor against the station sensor to determine if there is any offset (i.e. to determine if your sensor differs from the station sensor). Recording the temperature can include writing down your temperature on paper or recording it onto a computer spreadsheet.

Once all four temperature measurements have been recorded, companies must graph those four data points as temperature versus depth. Companies should use the known depth of the pool to estimate the depths for each temperature measurement. For example, in a pool 2.2 meters deep, companies could use 20 cm for their air depth, -10 cm for their surface temperature measurement, 110 cm for their midwater depth temperature measurement, and 220 cm for their bottom temperature measurement.

Companies will receive 10 points when they successfully graph the temperature versus depth. Successfully graphing the data is defined as plotting depth on the Y-axis and temperature on the X-axis and showing the resulting graph to the station judge. All dots should be linked by a line. Companies may use Excel or another computer program to plot their data points or may graph the data points on paper. MATE will not provide

computers or graph paper at the mission station; companies must provide their own method for graphing the data. All graphs must have their axes labeled. An example of a graph plotting temperature versus depth is represented below:

Data measured:

Location	Depth (cm)	Temperature (°C)
Air	30	31.4
Surface	-20	27.2
Mid-water	-110	25.5
Bottom	-210	25.4

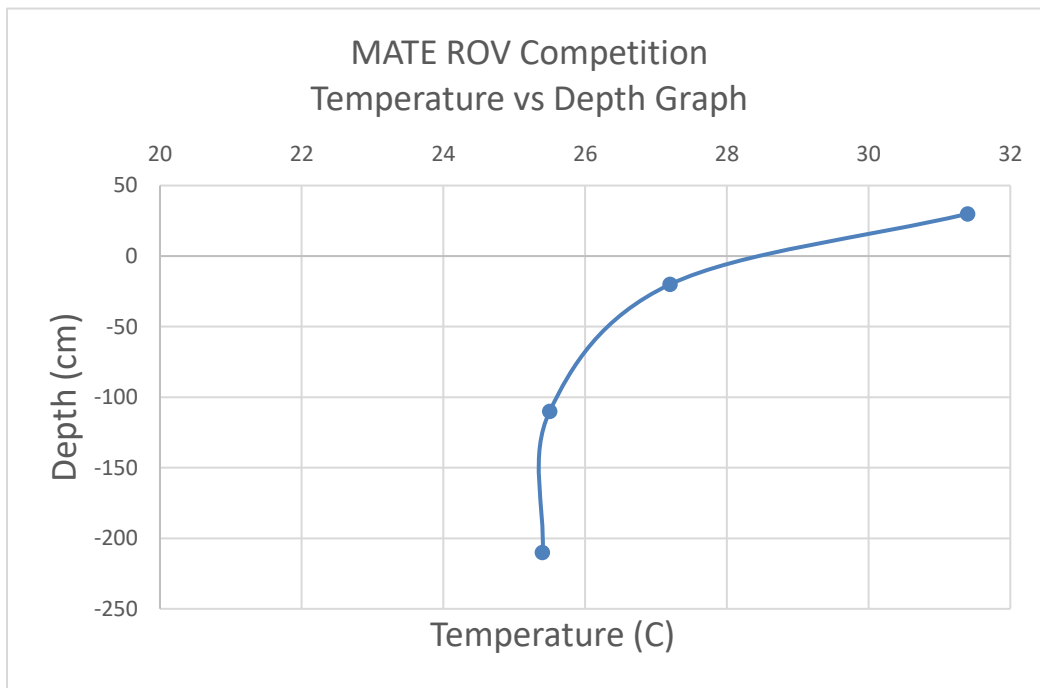

For companies that need help designing and building a vertical profiler, the SeaMATE Store sells a [vertical profiler kit](#). This kit provides the necessary components, as well as [instructions](#) on how to build a vertical profiler with a temperature sensor. NOTE: Companies are not required to use this kit and are free to design and build their own profiler.

If a company does not build a float, if that float does not contain a temperature sensor, or if the temperature sensor fails to send temperature data back to the mission station, companies should inform the station judge that they are choosing to instead graph data provided by MATE. The judge will then provide a set of depth versus temperature data. Once a company requests the MATE data, they can no longer receive points for collecting four temperatures and graphing those four temperatures. Instead, companies will receive 10 points for successfully graphing depth versus temperature. Successfully graphing the data is defined as showing the station judge a graph with temperature on the X-axis and depth on the Y-axis. MATE will not provide

computers or graph paper at the mission station; companies must provide their own method for graphing the data. All graphs must have their axes labeled.

Hints on building your vertical profiling float and incorporating a temperature sensor:

- One motor is sufficient to move your ROV up and down in the water. The same is true for a float.
- Your float only needs to move in two directions, up and down. A DPDT switch is capable of controlling a bilge pump motor on your float.
- Like GO-BGC floats, your float should be positively buoyant. When released by the ROV, it should float on the surface, but do not use so much flotation that your motor and propeller cannot move the float to the bottom of the pool.
- Simple underwater temperature sensors consist of a probe, which goes into the water, and a display that remains out of the water. These components are connected by a short pair of wires. Like the float itself, the temperature sensors may be connected to the mission station by the tether (most temperature sensors will need to be elongated and can use two wires in the tether). The temperature sensor probe must be attached to the float, but wires from the probe can extend from the float to the mission station where your display is located.
- The float wires and the temperature sensor wires may be incorporated into a single tether.
- Want to learn more about temperature sensors on your ROV or float? Check out the MATE ROV Competition [Sensors](#) presentation.
- Glass thermometers are not allowed in the pool! A glass thermometer on a float will NOT pass safety inspection.

Like ROVs, floats do not need to be overly complicated to work. Here is an example of a float using a propeller. While this float uses onboard batteries, which are not allowed for NAVIGATOR and SCOUT, it does use a motor with a shrouded propeller to complete vertical profiles.

[Rancho San Juan – Atlantico Float Documentation](#)

Here are examples of floats that use buoyancy engines to move up and down. These floats also use onboard batteries (again, these not allowed for NAVIGATOR and SCOUT), but are shared here to demonstrate different ways to move a float up and down.

[Florida Atlantic University High School – Night Owls Float Documentation](#)

[X-Academy – Hephaestus Robotics Float Documentation](#)

[Brooks DeBartolo High School – Phoenix Robotics Float Documentation](#)

Additional company float documentation can be found in the [2022 Archives](#) and the [2023 Archives](#). See the Technical Reports & Spec Sheets.

PRODUCT DEMONSTRATION RESPONSIBILITIES

Companies must design and bring any tools or devices to complete the required MATE product demonstration tasks.

PART 2: PRODUCT DEMONSTRATION PROP BUILDING INSTRUCTIONS & PHOTOS



The [product demonstration prop building instructions](#) will be released separately from this competition manual.

PART 3: VEHICLE DESIGN & BUILDING SPECIFICATIONS



1.0 GENERAL

Questions about production demonstrations and design and building specifications should be sent to the [Competition Technical Manager](#). Question, answers, and official rulings will be posted on the MATE ROV Competition [Q&A and Official Ruling Document](#). This ensures that all companies can view the questions and answers and helps to avoid duplicate questions. That said, please make sure that your question(s) has not already been asked – and answered – before emailing. When emailing their question, companies should reference

- Any specific specification or rule (e.g. ELEC-002S)
- Competition class

[Your regional coordinator or your regional contest's website](#) will inform you of any specific requirements or changes for your regional.

2.0 SAFETY

Safety is the competition's primary concern and guiding principle. Any system that is deemed unsafe by competition officials will not be allowed to compete. If a safety concern is identified during the initial inspection, companies are permitted to modify their system and have it re-inspected. Companies are permitted to have their vehicle re-inspected twice. If a company fails to pass its third and final safety

inspection, it is disqualified from the underwater competition portion of the event. There are NO APPEALS once an ROV has been disqualified.

NOTE for 2024!!!

MATE ROV Competition safety inspectors will be reinforcing the competition's emphasis on safety. Wiring discipline/workmanship and strain relief at both ends of the tether (ELEC-011S) will be areas of particular emphasis. **Companies that do not meet these safety standards will not be permitted to compete in the in-water events.** Additional examples of wiring workmanship will be included in the [MATE ROV Competition Safety Inspection Tutorial](#). See the [Tech Bulletin – MATE Expected Work Practices](#) for additional information.

Examples of safety violations from previous ROV competitions include:

- The ROV does not use Anderson Powerpole connectors to attach to main power.
- No SID was provided at the safety check.
- The ROV does not have a main fuse.
- The SID did not show a main fuse.
- Sharp items, or potentially sharp items, (fishing hooks, glass bottles, Mercury thermometers) were included on the vehicle.
- The vehicle motors were not waterproofed.
- Propellers were not protected inside the framework or were not shrouded.

2.1 Safety inspection protocol

1. Before entering the water for practice or a product demonstration run, the ROV system must go through a safety inspection. Once a company successfully passes inspection, they will turn in their safety inspection sheet to the safety inspector and receive a Blue PASSED Card with their company number on it. Companies must present the Blue PASSED Card to the pool practice/product demonstration coordinator before their vehicles are permitted to enter the water.
2. Competition staff will conduct a safety inspection of the vehicle using the [safety inspection rubric](#).
3. If the safety inspector(s) identify a safety violation, companies will have the opportunity to address it. The pool practice or product demonstration run schedule will NOT change to allow companies more time.
4. If during the second safety review the
 - a. violation has not been properly addressed or
 - b. another violation is revealedcompanies will have ONE additional opportunity to address the issue.
5. If during the third safety inspection a violation still exists, safety inspectors will request that the Chief Judge(s) review the violation. If the Chief Judge(s) confirms the violation, companies will not be permitted to participate in the underwater product demonstration component of the competition. However, companies can still participate in the engineering and communication (technical documentation, engineering presentation, and marketing display) component.
6. Reminder: All companies must present the Blue PASSED Card to the pool practice or product demonstration judge before placing their vehicles in the water. In addition, product demonstration

station judges and competition officials can pause or stop a product demonstration run at any time if they feel that there is a potential safety concern.

Your regional competition may use a system other than a Blue PASSED Card, but all companies must pass a safety inspection before entering the water. Contact [your regional coordinator or visit your regional contest's website](#) to determine if a Blue PASSED Card or another system will be used for safety verification.

2.1.1 System Interconnection Diagram (SID)

To pass the safety inspection, companies must provide a system interconnection diagram (SID) of their vehicle control system. An SID is an electrical diagram of their wiring, including their control box, motors, and any other electrical systems on their vehicle. The SID should separate and show what systems are on the surface and what systems are on the vehicle. The SID must not exceed one page in length. **The diagram MUST show an ROV system fuse. SIDs that do not show a fuse, utilizing an ANSI, NEMA or IEC symbol, with the size of the fuse marked, will not pass their safety check.**

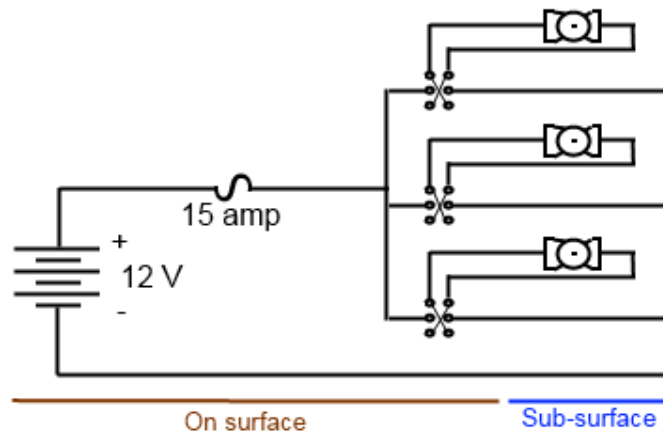



Diagram: An example of an acceptable SID.

Companies should create their own SID. Do not simply copy the above SID, or another SID produced by MATE, including those provided with kits purchased through the SeaMATE store. SIDs help to understand how electricity flows through your system and will provide a better understanding of ROV operations.

DOC-004: Any electrical diagram should use ANSI, NEMA, or IEC symbols as often as possible; it is required for the fuse. They should be neatly hand drawn or created using a CAD software program.

Item	ANSI	IEC
FUSE		

ANSI: American National Standards Institute

IEC: International Electrotechnical Commission

NEMA: National Electrical Manufacturers Association

Note: Companies that do not hand draw their SID may use free drawing software such as MS Paint or [OpenOffice](#) to create their diagrams.

2.2 Safety inspection completed

Companies must complete their safety inspection before entering the water for practice or a product demonstration run on the day of the competition.

3.0 SPECIFICATIONS

The ROV must meet the following requirements to compete in the event:

3.1. Operational

3.1.1 Multiple Vehicles

OPER-001: MULTIPLE VEHICLES ARE NOT PERMITTED. Companies are required to design and build ONE ROV that can complete the necessary product demonstration tasks. All ROV components, including cameras and payload tools, must be connected to the ROV.

3.1.2 Environmental

OPER-002: The ROV System must be able to function in fresh, chlorinated water with temperatures between 15°C and 30°C. The water should be considered conductive of electrical currents.

OPER-003: Visibility in the pool is unlimited. The pool will not be covered or purposefully darkened in any way. However, wind, divers, or ROVs may create ripples on the surface that affect visibility. Companies should plan accordingly.

OPER-004: There will be no water currents intentionally created. However, depending on the venue, pressurized pool filtration system outlets may cause unexpected currents.

Note: Contact [your regional coordinator or visit your regional contest's website](#) to learn more about the environmental operating conditions of the competition pool. Some pools may have sloping bottoms or other features that could affect your ROV's performance.

3.1.3 Service Requirement

OPER-005: Companies shall provide a product demonstration team of at least 3 but no more than 4 people to operate the ROV on the pool deck. Companies may have more than 4 people, but only 4 company members are allowed on the pool deck to operate the vehicle.

3.1.4 Maintenance

OPER-006: All work and system maintenance during operations shall be conducted by company personnel. Work of any kind must NOT be done by mentors or advisors.

3.2. Mechanical/Physical

3.2.1 Tether Length

MECH-001S: ROVs must be capable of operating in a maximum pool depth of 4 meters (13 feet). All underwater product demonstrations will take place within 6 meters (20 feet) from the side of the pool. Tether lengths should be calculated accordingly.

Note: Many SCOUT class competitions are held in water less than 4 meters deep. Contact [your regional coordinator or visit your regional contest's website](#) to determine the maximum depth of the SCOUT competition.

3.2.2 Vehicle Deployment and Recovery

MECH-002S: The product demonstration team must be able to carry the entire vehicle by hand. The crew must be able to hand launch and recover the ROV. No lifts or levers may be used to launch the ROV.

3.2.3 Propellers

MECH-003S: Propellers must be enclosed inside the frame of the ROV or shrouded. Companies that have propellers protruding outside of their frame will not pass the safety inspection and will not be allowed to compete.

3.3. Electrical

ELEC-001S: All power provided to your ROV system must be obtained from the MATE competition power supply. This is a singular point of connection; all power to your ROV must pass through the MATE-provided fuse on the supply AND the single fuse in your wiring.

ELEC-002S: MATE will provide a nominal 12VDC power source at the product demonstration station. This power source may be a battery or a power supply. Nominal voltage may be as high as 14.8 volts.

ELEC-003S: Voltage may never be increased above the nominal 12 volts anywhere in the ROV system.

NEW for 2024!!!

3.3.1 Non-ROV devices

The vertical profiling float with a temperature sensor is considered a non-ROV device. This is a device separate from the ROV that a company can deploy and control to fulfill its mission. The following are rules for the float.

ELEC-NRD-001: The vertical profiling float MUST be powered from the surface; it may not use onboard batteries. **Voltage is limited to 12 VDC maximum; amperage is limited to 6 amps maximum.** All power for the non-ROV device must come from a surface supply, must go down tether wires, and must go through a single fuse (see ELEC-NRD-004).

The temperature sensor on the non-ROV device may be powered independently from the vertical profiling float if the sensor:

- Is purchased “off the shelf” with integrated batteries
- Has a voltage less than or equal to 9v

Provided the off-the-shelf temperature sensor system meets the above requirements, the system does not need to be opened to insert a fuse. **This rule is for the non-ROV device temperature sensor only!** This does not apply to the ROV.

A tether is limited to 6 conducting wires. I.e. your tether may only have 6 wires going from the surface controls to the float. **You may not use pneumatics or hydraulics on your float.** Only electrical wires are allowed to be connected to the float.

ELEC-NRD-002: The vertical profiling float non-ROV device may use thrusters or a buoyancy engine to descend/ascend but no cameras are allowed on the float.

ELEC-NRD-003: Connection to power must be red/black Anderson Powerpole Connectors. The red and black pole pieces must be attached together. Loose Powerpoles (those not attached together) will not pass safety inspection. MATE will provide a 12-volt power source for the float at the mission station.

ELEC-NRD-004: A 7.5-amp (or less) fuse is required. The fuse must be installed in the positive power supply line within 30 cm of the power supply attachment point.

- ATO type blade fuses or MINI blade fuses MUST be used for any fusing. These fuses provide easy visual inspection for amperage using industry standard color codes.
Fuse Reference: [ATO fuse](#) [MINI fuse](#)
These fuses are all rated for 32VDC and are color coded for amperage.
- All blade fuses MUST correspond to the standardized color codes listed on the fuse links above.

3.3.2 Current

ELEC-004S: ROVs are limited to 15 amps.

The ROV **MUST** have a 15A maximum (or smaller) fuse in the positive power supply line within 30 cm of the positive Anderson Powerpole connector. The SID must show this fuse, using a proper fuse symbol, and include the amperage rating of the fuse.

NEW for 2024!!!

Companies MUST use ATO type blade fuses or MINI blade fuses. These fuses provide easy visual inspection for amperage using industry standard color codes.

Fuse Reference: [ATO fuse](#) [MINI fuse](#)

These fuses are all rated for 32VDC and are color coded for amperage. All blade fuses MUST correspond to the standardized color codes listed on the fuse links above.

COMPANIES WITHOUT A PROPER BLADE FUSE WILL NOT PASS SAFETY INSPECTION!

NOTE for 2024!!!

ELEC-005S: ROV systems are allowed only one replacement fuse during the product demonstration run. In the event that the ROV system blows the second fuse during the product demonstration, time will stop, the product demonstration run will be over, and no additional points will be earned. Note: Companies must provide their own replacement fuses. MATE will not provide replacement fuses.

3.3.3 Power Connections

ELEC-006S: The MATE ROV Competition requires that all ROVs use Anderson Powerpole connections ([30 Amp Permanently Bonded Red/Black Anderson Powerpole Connectors | Powerwerx](#), [Power and Powerpole Assembly Kit \(suitable for Angelfish and Pufferfish\) – SeaMATE](#)). Power supply connections at all regional competitions will be red/black Anderson Powerpole Connectors.

Anderson Powerpole connections are two-piece connectors as shown in the picture below.



NOTE for 2024!!!

The red and black Powerpole pieces must be attached together. Loose Powerpoles (those not attached together) will not pass safety inspection.

Part specification and part numbers

Anderson Powerpole – red and black connector with 30 amp contacts

Red is connected to power supply positive.

Black is connected to power supply negative.

Since Anderson sells the connectors in 2500 and 200 piece quantities, these connectors are available from distributors.

Powerpole Assembly Instructions

<http://www.powerwerx.com/assembly.asp>

<http://www.wb3w.net/powerpoleinst.htm> (see the section on using the TriCrimp tool)

YouTube video for Assembly

Part 1: https://www.youtube.com/watch?v=8_DPPuQN8R4

Part 2: <https://www.youtube.com/watch?v=EsSsr2zGFqI>

ELEC-007S: The power supply may be located up to 2 meters from the station and may be located on either side of the station. MATE recommends a power cable long enough to reach the power supply up to 2 meters from your control system.

3.3.4 Exposed connections and disposable motors

ELEC-008S: All electrical components going into the water must be waterproofed. ROVs with electrical connections that are exposed to the water and not sealed will not be permitted to enter the pool. Disposable motors (motors with no waterproofing) are not permitted. Taping a connection with only electrical tape does not constitute a sealed connection. The process of sealing electrical connections must include methodologies such as, but not limited to, silicone RTV, hot melt glue, epoxy, self-vulcanizing tape, and enclosing the connection inside a housing.

3.4 Onboard Electrical Power

ELEC-009: Onboard electrical power is not allowed. All power for the vehicle must come down the tether. Batteries (9-volt, AAA, AA, etc.) are **NOT** allowed under any circumstances.

NOTE: *Water leaking into a closed battery container can result in the generation of hydrogen gas. This gas can build up inside a pressure housing and create an unsafe situation. For this reason, onboard batteries are NOT allowed under any circumstance. Any device that needs power must obtain that power directly from the ROV tether. For devices that operate at a voltage other than the tether voltage, an onboard ROV converter may be included. The converter must be sealed and not exposed to water. This rule includes commercial “watertight” battery containers; no battery of any type is permitted on any competition vehicle.*

3.5 Power Shutdown

ELEC-010S: Power shutdown: For safety purposes, any ROV that is disconnected from the surface power supply must stop functioning in less than 5 seconds.

3.6 Fluid Power

Any vehicle using fluid power must provide a fluid power diagram. Fluid power is defined as hydraulic pumps (water) or pneumatic pumps (air) on the vehicle or on the surface

FLUID-001S: Electrical pumps of any sort are NOT allowed. Companies may only use manual pumps (hand or foot pumps) to push fluids (including air) down the tether and to their vehicle.

FLUID-002S: Companies may only use WATER as their hydraulic fluid. Companies may only use AIR as their pneumatic fluid.

FLUID-003S: Companies may not use pressure accumulators. Pressure inside any container must never exceed the ambient pool pressure. If air is pumped into a container on the vehicle, that container must be open to the water. Vent holes on the container must be at least ¼-inch (6.35 mm) in diameter.

For example: A company wants to fill a PVC pipe container on the vehicle with air. Companies may only use a manual pump (hand/foot powered bicycle pump) to push air down to the vehicle. The company drills four ¼-inch holes in the bottom of the pipe. As they pump air into the container, it will displace the water out of the holes in the bottom of the pipe. However, the pressure inside the container can never get above the ambient pool pressure; excess air will come out the holes on the bottom of the pipe once all the water has been displaced.

3.7 Control Systems

ELEC-011S: Control systems must be built in a neat and workmanship like manner. Loose components and unsecured wires may not pass safety inspection. All wires entering and leaving the control system must have adequate strain relief and wire abrasion protection as the wires pass through the box.

3.8 Cameras and monitors

CAM-001: Cameras are not required in the SCOUT class. However, if a company chooses to use cameras on their ROV, they are limited to one video display screen. This monitor must be provided by the company; MATE will not provide a video display monitor for SCOUT companies.

CAM-002: All cameras and the one monitor **MUST** be powered from the MATE 12-volt supply. Companies may not plug cameras or the monitor into AC wall sockets. Companies may not use their own battery packs or USB to run cameras or monitors. **NO EXCEPTIONS.**

3.9 Lasers

SCOUT class companies may **NOT** use lasers on their vehicles.

PART 4: COMPETITION RULES



Teamwork/
Collaboration



Content
Knowledge



Safety



Vehicle Design,
Buoyancy, Propulsion

4.1 GENERAL

- All members of the company and their supporters must follow the safety regulations of the ROV competition, pool facility, and event venue.
- All company members and their supporters are expected to conduct themselves in a professional and responsible manner during the competition. Disrespectful behavior towards the judges, officials, pool staff, audience, or other companies will lead to penalty points or disqualification.
- Sabotaging, stealing, or pilfering equipment of other companies will lead to disqualification. Companies found cheating will also be disqualified.
- The MATE ROV competition is, at its core, designed to be an educational and inspirational event for **STUDENTS**. It is designed to challenge them to apply the physics, math, electronics, and engineering skills they are learning in the classroom to solving practical problems from the marine workplace. (See the [MATE Competition Philosophy](#).)

It is expected that all “adults” (non-students; e.g. teachers, mentors, parents) involved in the competition limit their input to educational and inspirational roles. Actual construction of the ROV (particularly in the complex electrical and software areas) must be completed by the students. Adults

should teach and advise students about design, electronics, software, and construction, but not complete the work for the students. Throughout the process adults are encouraged to focus on benefits to the students from the process and not simply winning. If it becomes apparent that adults exercised more than an advisory role, judges reserve the right to deduct points or, in extreme cases, disqualify companies from the competition.

ALL work done on the vehicle must be conducted by company members. This includes any work done at home, at school, or during the MATE ROV competition. Teachers, mentors, parents, and non-competing students are not permitted to work on the ROVs. They may provide advisory input, but they may not work on the ROV directly. This includes writing or editing software code. All mechanical, electrical, and software modifications and/or repairs to the ROV must be completed by students.

With learning at its core, the MATE competition encourages students to utilize and build upon their skill sets to find creative solutions to designing and building their ROV. Students gain valuable skills and knowledge when creating a component from “scratch,” which is apparent to judges as they review the technical documentation and engineering presentation. However, as they move through the process of analyzing their designs and identifying building materials, students may decide to either build a component from “scratch” or purchase it from a commercial vendor.*** So, while original solutions are encouraged, the use of commercial components is acceptable, provided 1) that the components adhere to the design and building as well as safety specifications for the particular competition class and 2) more importantly, that the students can provide a reasonable, logical explanation for buying versus building.

The competition scoring rubrics are designed to reflect this; points are awarded based on students’ abilities to explain and justify how all of the components and systems work together as an integrated ROV, regardless if they purchased them, pulled them from public libraries, or made them themselves.

***Note “commercial vendor” includes the [SeaMATE store](#) and other competition programs that sell educational robotics kits. SeaMATE kits were created to remove barriers to participation for teachers and schools unable to easily 1) find parts and materials and 2) set up accounts with multiple vendors. The kits are part of a larger educational package offered by SeaMATE that includes curriculum materials, videos, and other resources to support and enhance learning. And learning is what students who use SeaMATE (or other) kits will be expected to demonstrate during and through the [ENGINEERING & COMMUNICATION](#) components.

It should be noted that purchasing and competing with complete, assembled, commercial ROVs is not permitted.

4.2 PROCEDURAL

- Companies must compete during their assigned time slots. Your company is **NOT** permitted to switch time slots with another company. Failure to show for your scheduled product demonstration or for

your company's engineering presentation will result in "no score" for that particular competition category. **No exceptions.** Assigned time slots will be sent out in advance so that any scheduling concerns can be addressed prior to the event. Contact [your regional coordinator](#) at least four weeks before the competition if you know you have a scheduling concern.

- While there is no limit to the number of students who can compete as part of a company, **the product demonstration team (aka demo team) is limited to four students.** The demo team is defined as the team of students who operate the vehicle and its associated equipment during the product demonstration. The product demonstration is held at a "product demonstration station." Only four students will be allowed to enter the product demonstration station, launch, pilot, and perform the tasks. Instructors, mentors, and/or non-student members cannot participate as part of the demo team. If a regional offers two product demonstration attempts, **companies may alternate students on the demo team for the two product demonstrations. See below for additional information about the number of attempts.** (All members of the company should participate in the engineering and communication components; see [ENGINEERING & COMMUNICATION](#) for more information.)
- Only the demo team members and judges are allowed at the product demonstration station during the product demonstration, which includes the set-up and demobilization periods. Other members of the company, instructors, mentors, audience members, and observers (press or special invited guests) must remain outside the product demonstration station or in designated viewing areas.
- Instructors, mentors, parents, and "fans" are **NOT** permitted at the safety inspection stations or repair tables. Two warnings will be issued before individuals not following this rule will be asked to leave the venue.
- In addition, instructors, mentors, parents, and fans are **NOT** permitted to work on the ROV. Individuals who are seen working on the ROV who are not student company members will be issued a warning. Two warnings will be issued before individuals not following this rule will be asked to leave the venue. If companies choose to take their ROVs off the competition grounds for maintenance and repair, they are expected to observe this rule in the interests of the spirit of the competition.
- Video devices may be used to record the underwater activities for entertainment and learning purposes **only.** Video will not be used as an instant replay to review judges' decisions or to challenge product demonstration timing.
- Companies will compete in ONE product demonstration that consists of four distinct tasks. Companies may get up to **TWO** attempts to complete each product demonstrations. If that is the case, the **higher** of the two scores will be added to the engineering and communication score to determine the total, overall score for the competition.

In general, the product demonstration time consists of a 3-minute set-up period, a 10-minute performance period, and a 2-minute demobilization period. If the demo team and all of their

equipment are not out of the product demonstration station at the end of the 2-minute demobilization period, the company will be **penalized 1 point for each additional minute**.

Note: Regional contests may or may NOT offer companies two attempts at the product demonstration tasks. In addition, the product demonstration time frames for set-up, performance period, and demobilization may be different at your regional contest. Contact [your regional coordinator or visit your regional contest's website](#) for more information.

- Manipulating the tether to free it from underwater obstacles is permitted. Pulling on the tether to speed up the recovery of items or to return your vehicle more quickly to the surface is not permitted and will result in penalty points. Judges will issue one warning if tether pulling occurs. Each future infraction will result in **5** points deducted from the final product demonstration score.
- If your vehicle is completely disabled and/or its tether tangled and unable to free itself from the underwater environment, SCUBA divers can be called in to assist. However, the product demonstration time will NOT stop and **5** points will be deducted from the final product demonstration score.

Diver assistance may not be available at your regional competition. Contact [your regional coordinator or visit your regional contest's website](#) to determine if diver assistance will be available at your regional competition.

- No demo team member shall enter the water to complete an object recovery. Only arms and hands are allowed into the pool to retrieve an object or to retrieve the vehicle. Companies will be disqualified or penalized depending on the severity of the infraction.
- Communication using cell phones, text messaging, and online social media tools such as Skype, Facebook, Twitter, instant messaging, etc. is NOT permitted during the product demonstration, either between the demo team members at poolside or between any demo team member and anyone outside of the product demonstration station.
- **Product demonstration judges and other competition officials will only communicate with students.** Judges and officials will NOT communicate with mentors, parents, or other non-student members regarding product demonstration information, challenges, or other issues except during pre- and post-competition briefing sessions.

Companies that want to issue a challenge during the product demonstration run should immediately communicate this challenge to the product demonstration judges. The judges will discuss and attempt to resolve the issue. If a decision cannot be made, the product demonstration judges will consult with the head judges, competition technical manager, and/or the competition coordinator to resolve the issue.

4.3 DESIGN & SAFETY CONSIDERATIONS

- The competition coordinators and host venues stress the importance of safety practices and procedures to all companies. The score sheets and rubrics will reflect the MATE ROV Competition's efforts to encourage and reward companies that demonstrate exceptional safety practices and procedures.
- **ALL ROVS MUST PASS A SAFETY INSPECTION CONDUCTED BY COMPETITION OFFICIALS PRIOR TO ENTERING THE POOL.** These inspections will be conducted topside to ensure that ROV systems meet the design and building specifications and do not pose a risk to the integrity of the event venue. See [VEHICLE DESIGN & BUILDING SPECIFICATIONS](#) for additional information.

ROV MOTORS MUST BE WATERPROOFED! No exceptions. You may use already waterproofed motors (bilge pump motors, etc.) or you may choose to waterproof small electrical motors.

- Propellers must be enclosed inside the frame of the ROV or shrouded. **Companies that have propellers protruding outside of their frame will not pass the safety inspection and will not be allowed to compete.**
- Cameras and monitors are permitted but aren't needed as companies are allowed to look into the pool to pilot the ROV. If your company chooses to use a camera(s), the camera(s) and monitor must be powered off of the 12-volt battery or power supply provided by the contest organizers. **NO AC POWER IS PERMITTED WHATSOEVER.** In other words, you can't plug your ROV into a wall socket!
- Radio transmitters that operate on a separate battery are permitted. No batteries are permitted to be in or on the water. No exceptions. Note that although wireless controllers are allowed, MATE is not responsible for wireless interference. Adjacent wireless controllers with a battery that has a higher charge may "hijack" control signals. MATE will not stop the clock to resolve wireless control issues under any circumstance. Companies deciding to utilize wireless controllers do so at their own risk.
- Safety must also be a priority when operating your ROV poolside. Keep an eye out for tripping hazards. Make sure that your connections to the battery or power supply are not lying in pools of water on the deck. During your product demonstration, be sure to secure any equipment so that it does not fall, damage the deck, or cause injury.
- Loose fitting clothing, jewelry, and long hair could all become safety issues. Consider securing long shirts or baggy pants, removing jewelry, and tying back long hair when working on or operating your ROV.

- ROVs may be constructed out of materials of your company’s choice, provided they meet the design and building specifications and safety regulations. Warning labels should be posted on potentially hazardous components of your ROV system.
- **Closed-toed shoes are required on the pool deck and anytime you are working on your ROV.** Safety glasses or goggles should be worn when working on your ROV.
- Personal flotation devices (PFDs) may be required when launching and recovering your vehicles. Contact [your regional coordinator or visit your regional contest’s website](#) to determine whether this is a requirement at your regional event. If PFDs are required, they will be provided by the regional coordinator.

PART 5: ENGINEERING & COMMUNICATION



MATE has created an ROV Competition [Marketing Kit](#) that includes logos and guidelines for their use.

The ability to communicate information about your vehicle and the design and building process is equally as important as how well your vehicle performs. Strong communication skills are an essential part of good business practices and one of the most in-demand skills in the constantly evolving, ever-changing workplace.

To emphasize this point, the competition requires the following five engineering and communication components:

- Company spec sheet
- Technical (written) documentation. Examples of SCOUT technical documentation from previous competitions: [Harrington Middle School HMS Seabots](#) (SCOUT 2021) and [Northstar Marine Tech, Inc](#) (SCOUT 2016)
- Engineering (oral) presentation (Videos of engineering presentations can be found on the MATE Vimeo site: [Hawks Engineering](#) (RANGER 2021). This is RANGER presentation (higher level, 15 minutes not 10 minutes) but is a good example of a presentation.

- Marketing display. Examples of SCOUT marketing displays from previous competitions: [Glacier High School – Betta](#) (SCOUT 2023) and [Aptos Jr. High School – Circuit Breakers](#) (SCOUT 2023)
- Corporate Responsibility (OPTIONAL)

NOTE: Regional contests may not require all of the Engineering & Communication components. Contact [your regional coordinator or visit your regional contest’s website](#) for more information.

See the **TIPS FOR EFFECTIVE WRITTEN AND ORAL COMMUNICATION** for additional information.

NOTE for 2024!!!

Your company should refer directly to the scoring rubrics posted under [Scoring](#) for details on what is required for your technical documentation, engineering presentation, and marketing display. The judges will use the rubrics to evaluate and score these engineering and communication components.

5.1 COMPANY SPEC SHEET

The purpose of the company spec sheet is to provide the judges with a “snapshot” of your company. It includes basic information about your company and vehicle.

Company spec sheets will be reviewed by MATE competition coordinators. Companies will receive up to 20 points for submitting a spec sheet that is **one page** in length, follows the file size and naming specifications, and contains **all** of the following information:

COMPANY SPECS

- **Company and school, club, or community organization name**
- **Home state and/or country**
- **Distance required to travel to the world championship**
- **History of MATE ROV competition participation.** Be sure to specify if your company and/or the members of your company are “new” or “returning.”
- **Company photo and caption indicating members’ names and roles (e.g. CEO, CFO, Design Engineer, Pilot, etc.).** This photo should include all of the members of your company.
- **Range of grade/college levels represented by the members of your company**

ROV SPECS

- **ROV name** if applicable
- **Total cost.** You must include the approximate cost of any donated items.
- **Size and weight measurements**
- **Total student-hours to design and build.** This should include the number of hours that each and every member of the company worked on the vehicle.
- **Safety features**
- **Special features**
- **Photo of the vehicle**

REMINDER!!! If all of the above information is included, the specifications for length, size, and naming conventions are followed carefully, and the document is submitted on time, this is an “easy” 20 points! You can find the company spec sheet scoring rubric posted [here](#).

5.2 TECHNICAL DOCUMENTATION

The purpose of the technical documentation is to challenge you to communicate information using clear and concise text along with graphics, illustrations, and data that add to and complement (and not distract from) the information. Your company must organize and present the information in a way that is logical and complete. The document should focus on the technical and safety aspects of your ROV/ROV systems, the design rationale behind your engineering decisions, and a critical analysis of testing and troubleshooting done on the vehicle. You should consider this document a reference for both judges and future team members (part of the company’s institutional knowledge).

Your company’s technical documentation will be reviewed and evaluated by a panel of working professionals – individuals who represent science, exploration, government, and industry.

Each judge on the panel will award a score (50 points max). Judges’ scores and comments will be returned to you shortly after the event.

NOTE: The judges will not review and rescore revised versions of your technical documentation during the competition.

Use the technical documentation scoring rubric posted [here](#) as the guideline for the required components for the technical documentation. This rubric will be posted by March 1, 2024. In the meantime, companies may refer to the [previous year’s rubrics](#) for a general idea of the categories and points.

5.3 ENGINEERING PRESENTATION

The purpose of the engineering presentation is to challenge you to communicate information with words and “props” (i.e., the ROV). Your company must organize and present the information in a way that is logical and covers the development and testing of your ROVs and the formation and development of their team. The presentation should be delivered as a “technical brief.” The presentation is the opportunity your company has to 1) communicate directly and in person your critical thinking, creativity, and engineering reasoning and 2) demonstrate your individual and collaborative contributions to the creation of the vehicle.

During the competition, your company will have 5-10 minutes deliver your presentation to a panel of working professionals – individuals who represent science, exploration, government, and industry. After the presentation, the judges will take 5-10 minutes to ask the members of your company questions about your ROV. The judges will evaluate both your presentation and responses to their questions. Each judge on the

panel will award a score (50 points max). Judges' scores and comments will be returned to you shortly after the event.

All student members of your company must be prepared to participate in the presentation and question and answer (Q&A) period. You are required to have your ROV with you. During the Q&A, all members of the company should be prepared to answer. However, if one student is better able to answer a specific question, the others may pass the question to that student to answer. For example, if a judge calls on the pilot to answer a question about the tether, the pilot can respond by informing the judge that the tether manager was the lead on that system and allow the tether manager to answer without penalty or loss of points.

NOTE: The engineering presentation is designed to be a face-to-face interaction where students and representatives from industry become engaged in conversation. MATE will not provide audio visual aids, such as slide projectors, computer projection screens, white boards, etc.; however, you are welcome to distribute handouts to help judges better understand the information that you are presenting. Electronic forms of presentation (e.g. PowerPoint or Keynote slides) **are NOT permitted.**

Instructors, mentors, family members, friends, and members of other companies are permitted to attend. However, we ask that those in attendance be respectful and courteous throughout the presentation and follow-up question and answer period. Be mindful that this presentation may be a stressful time for the students. If the room becomes crowded or the spectators become distracting, it is up to the judges' discretion to request that some or all spectators leave the presentation. **While they are permitted to attend, instructors and mentors are not allowed to participate.**

Use the engineering presentation scoring rubric posted [here](#) as the guideline for the required components for the engineering presentation. This rubric will be posted by March 1, 2024. In the meantime, companies may refer to the [previous year's rubrics](#) for a general idea of the categories and points. Judges may ask questions regarding any of these topics not covered in the presentation as well as other questions about the vehicle, the mission theme, or the company.

Preparing for your engineering presentation and Q&A

- Make sure that every member of your company has a good, general working knowledge of your vehicle, even though they may have specialized in one specific aspect of its design and construction.
- Encourage each member of your company to keep a project notebook. Before the competition, set up a time where you compare notebooks. One member might have written more information about your ROV's electrical system, while another might have included details about buoyancy that others forgot. This exercise will help to refresh everyone's memory about the design and building process. If your company submitted technical documentation, make sure that all company members have read and are familiar with it. This exercise will help to familiarize everyone with all aspects of the project.
- Generally, you will have more to say about your ROV than can be presented in 5-10 minutes. That is why it is critical to organize your material and practice communicating it. However, avoid coming across as having memorized your presentation verbatim. Judges want to see that you are prepared

and understand the information, not that you can simply regurgitate a rehearsed speech from memory. Ask your instructors or mentors to give you feedback.

Other important items

- If during the engineering presentation it becomes apparent that instructors, mentors, and other adults associated with your company exercised more than an advisory role, judges reserve the right to deduct points or, in extreme cases, disqualify companies.

5.4 MARKETING DISPLAY

The purpose of the marketing display is to challenge you to present technical information in a way that is appealing to and understood by a non-technical audience. It is the promotional piece – you must not only present information about your ROV and your company, but you must also use graphics and design to publicize and “sell” (convince viewers of their value and excellence) your products and people.

During the competition, your company’s display will be evaluated and scored by a completely different group of working professionals – individuals who will represent science, business, government, industry, and education/outreach.

While some judges will have a technical background, others will have a communications, marketing, or public relations background. In addition, there will be visitors to the competition who may not completely understand what an ROV is or how it is used. Think of these visitors as potential future clients who may authorize funding for your work but have a limited understanding of the technology (i.e., you need to explain your technology, the tasks at hand, and “sell” them on YOUR products and services). Design your display to communicate to this type of audience.

Each judge will award a score (50 points max). Judges’ scores and comments will be returned to you shortly after the event.

Each company will have a space approximately 3-feet x 3-feet for its display. Depending on your regional, tables may or may not be provided. Contact [your regional coordinator or visit your regional contest’s website](#) for more information.

Use the marketing display scoring rubric posted [here](#) as the guideline for the required components for the marketing display. This rubric will be posted by March 1, 2024. In the meantime, companies may refer to the [previous year’s rubrics](#) for a general idea of the categories and points.

Creating an effective marketing display:

- Address the theme and make real-world connections.
- Reflect your company’s personality and mindset.
- Make key points and be concise.
- Keep the general public in mind.

- Make sure to label any and all figures, graphs, diagrams, and photographs and credit the source.
- Maximize the use of the 36” by 48” display space.
- Make sure that it is both informational and aesthetically pleasing.

Note: “Accessories” such as video footage, PowerPoint slide presentations running on laptop computers, video projections, etc. are permitted but should be used with discretion. Remember that the judges will have a limited amount of time to evaluate your marketing display and may find excessive use of audio or video presentations distracting.

However, if you do make a video of your ROV building or competition experience, please submit information about it to the [MATE ROV Competition officials](#) so that it can be shared via MATE’s YouTube and Vimeo channels.

5.5 CORPORATE RESPONSIBILITY

The MATE ROV Competition uses underwater robotics to inspire and encourage students’ interest in STEM (science, technology, engineering, and math) education and careers. Recognizing that the students who participate in MATE competitions are powerful ambassadors for the program as well as effective leaders in raising awareness of important issues and bringing about positive change, companies have the opportunity to earn up to 20 points for “corporate responsibility.”

Corporate responsibility includes, but is not limited to, the following:

- **Mentoring** consists of, for example, providing guidance to other students in your area who are designing and building an ROV for the competition or a science or other project.
- **Engaging the community** includes demonstrating your ROV and sharing information about your company at festivities and other community-wide events. Presenting to a Rotary Club or your school districts board of directors are other examples.
- **Media outreach** consists of:
 - o Developing a list local media contacts
 - o Writing a press release about your participation in the MATE ROV competition
 - o Distributing it to your media contacts
 - o Following up with your media contacts to see if they’re interested in your company and its ROV
 - o Compiling a summary of results

Here are some [general guidelines](#) for working with the media. They are specific to the World Championship but can be easily modified for regional events.

- **Raising awareness of environmental, social, and governance (ESG) issues. Just look at this year’s theme and product demonstration tasks for ideas – from installing marine renewable energy to reduce carbon emissions to helping and healing the environment to monitoring the health of the oceans.**

- Corporate responsibility efforts will be reviewed by competition coordinators and awarded 0 to 20 bonus points, depending on the number and scope of the outreach and awareness activity(s), i.e., the number of other students or members of the community engaged, the number of mentoring sessions, etc.

Make sure to include the following information in your write-up:

- Type of activity (e.g. mentoring, exhibiting at a community event, raising awareness)
- Locations, dates, and the amount of time spent on the activity
- Number of students or community members (if a large event, this can be an approximate) involved
- Description of your actions, outcomes, and other information that helps to demonstrate the quality of your time and efforts
- For media outreach, please submit a copy of your press release, a copy of your media contacts list, and a summary of news articles, TV or radio coverage, etc. that your company received. Include copies of articles and URLs and list any television or radio coverage. Be sure to include name of outlet, date, and a summary of the coverage.

TIPS FOR EFFECTIVE WRITTEN AND ORAL COMMUNICATION

Communicating ideas about how to solve a problem and evaluating those ideas against alternative ideas is a critical skill for anyone entering the workplace. It is a skill that is directly linked to decision making about whether or not to hire (or fund) us and our ability to have a say in the work that we do.

The key to a successful technical documentation and engineering presentation is the way that critical thinking and engineering reasoning are communicated. You can think of the process as technical “storytelling.”

Technical storytelling includes the use of text, images, schematics, and data to communicate the “story” of how your company brainstormed and evaluated ideas to come up with your solution (e.g. ROV, payload tools, and operational strategies) to the problem at hand (product demonstration tasks). It also involves organizing information to efficiently present your work and justify why you did what you did.

However, you should choose details with care. Each detail should help to answer the question “why is what you did the best solution for your company and for this competition?” Describe why a component in the system is important and how you chose it. Include specifications or dimensions only if they help to explain the “why” and “how” you made choices. Keep in mind that a mechanical drawing with dimensions can replace a lot of text and in many cases do a better job telling details of the story than text.

That said, if something is hard to describe clearly and completely with two to three sentences, consider whether using an image may help. A good technical document balances text and images to provide lots of information in a concise way, which helps give readers a detailed understanding while being quick and easy to read. Remember that your reader is new to your design and needs to understand both what your design is and the process you used to get there. Present text and images in a logical order that helps readers follow your design and building process and results.

Maintaining a project notebook is a good business practice that will help to capture ideas and document your company's progress – including your research, designs, trade studies, experiments, data, vehicle specifications, testing, expenditures, and donations. The notebook is also a place to keep track of your company member's contributions (time, support, etc.).

Along with your notebook, here are some items to consider as you prepare to tell your story:

- What was your company's "work breakdown structure" (tasks, time, and people)?
- What were the greatest constraints (schedule, budget, equipment, labor, logistics, etc.) on your design process?
- How did the product demonstration tasks and rules influence your design and decisions?
- What process did you use to evaluate different design solutions?
- What were the most important design decisions you made and why?
- How did you arrive at your final power budget? What trade-offs, if any, did you have to make and why?
- How do you calibrate your sensors?
- If your vehicle uses software, where does the code execute? Describe the flow and format of the data.
- Did you have a major troubleshooting experience? Any problem or procedure that takes more than 20 minutes to figure out is worth understanding and writing down.

PART 6: DOCUMENTATION



Communication



Autonomy



Obstacles



Project Management

Companies are required to submit a system interconnection diagram (SID) of their vehicle control system. Your regional may also require you to submit technical documentation and a company spec sheet.

Contact [your regional coordinator or visit your regional contest's website](#) to determine what documentation must be submitted for your regional and the date it is due.

DOC-001: Technical documentation: A technical document or engineering notebook about your vehicle that will be reviewed by a panel of judges. See the [technical documentation](#) section for more information on the contents required for the technical documentation.

DOC-002: Company spec sheet: A one page document that provides a snapshot of your company and ROV. See the [company spec sheet](#) section for more information on the requirement for the company spec sheet.

DOC-003: SID Electrical: Companies must provide a [system interconnection diagram \(SID\)](#) of their vehicle control system during their safety inspection.

DOC-004: Fluid power SID: Companies using fluid power (hydraulics or pneumatics) must provide a fluid power diagram. The diagram should separate and show what systems are on the surface and what systems are on the vehicle. A fluid power SID for simple syringe hydraulics would consist of a syringe box on the surface connecting to a syringe box on the vehicle.

The fluid power SID can be incorporated into the Electrical SID or can be a separate, one page document.

DOC-005: Documents may be due before the competition or the day of the competition. Regardless, companies **MUST** bring a SID of their ROV systems in order to pass the safety inspection!

NOTE: By submitting your documentation, you are giving the MATE ROV Competition permission to publish these documents on its web site.

6.2 KEY DEADLINES

Contact [your regional coordinator or visit your regional contest's website](#) to determine the key deadlines for your regional competition.