



2025 COMPETITION MANUAL NAVIGATOR CLASS

RELEASE: NOVEMBER 2024



MTS 
marine technology society



2025 MATE ROV COMPETITION:

UN Decade of the Ocean, MATE Year of the Great lakes:
Monitoring and Mitigating the Impacts of Climate Change on Our
Water World

NAVIGATOR CLASS COMPETITION MANUAL

For general competition information, including a description of the different competition classes and eligibility requirements, visit [Compete](#).

Contents

- OVERVIEW2
- THINK OF YOURSELVES AS ENTREPRENEURS3
- 10 CHALLENGES – 10 YEARS – ONE OCEAN 4
- PART 1: PRODUCT DEMONSTRATION 4
- OVERVIEW 4
- CONTEXT & NEED 6
- REQUEST FOR PROPOSALS (RFP) 7
- SIZE RESTRICTIONS16
- PRODUCT DEMONSTRATION17
- ORGANIZATIONAL AND OPERATIONAL EFFECTIVENESS17
- TASK 1: Shipwrecks, Spotter Buoys, and Flying Fish: Documenting the Impact of Climate Change and Invasive Species on the Great Lakes17
- TASK 2: Marine Renewable Energy: Producing Power from Our Planet While Monitoring Environmental Impact22
- TASK 3: *MATE Floats!*.....26
- PRODUCT DEMONSTRATION RESOURCES..... 30
- PRODUCT DEMONSTRATION RESPONSIBILITIES 30
- PART 2: PRODUCT DEMONSTRATION PROP BUILDING INSTRUCTIONS & PHOTOS ..31
- PART 3: VEHICLE DESIGN & BUILDING SPECIFICATIONS.....31
- 1.0 GENERAL31
- 2.0 SAFETY32
- 2.1 Safety Inspection Protocol 32
- 3.0 SPECIFICATIONS 34
- 3.1 Operational 34
- 3.2 Mechanical/Physical 35
- 3.3 Electrical 36
- 3.4 Onboard Electrical Power 41
- 3.5 Power Shutdown..... 41
- 3.6 Fluid Power..... 41
- 3.7 Control Systems 44
- 3.8 Command, Control, & Communications (C3) 44

3.9 MATE Provided Equipment	45
3.10 Laser Safety Rules.....	45
PART 4: COMPETITION RULES.....	47
4.1 GENERAL.....	47
4.2 PROCEDURAL	48
4.3 DESIGN & SAFETY CONSIDERATIONS	51
PART 5: ENGINEERING & COMMUNICATION	53
5.1 COMPANY SPEC SHEET.....	54
5.2 TECHNICAL DOCUMENTATION	54
5.3 ENGINEERING PRESENTATION	55
5.4 MARKETING DISPLAY	57
5.5 CORPORATE RESPONSIBILITY.....	58
TIPS FOR EFFECTIVE WRITTEN AND ORAL COMMUNICATION	58
PART 6: DOCUMENTATION.....	61
6.1 DOCUMENTATION.....	62
6.2 KEY DEADLINES.....	62



This work is licensed under a [Creative Commons Attribution-NonCommercial-NoDerivatives 4.0 International License](https://creativecommons.org/licenses/by-nc-nd/4.0/). Under this license you may download this document. Please give credit to the MATE ROV Competition. You may not use these materials for commercial purposes without written permission from the MATE ROV Competition. Please click on the Creative Commons link above for license details.
materovcompetition.org

OVERVIEW

From Technical Talents to Teamwork, Problem-Solving, Creativity, and Critical Thinking: MATE Develops Skills for Success in the Workforce.

As you prepare to develop and deploy technologies to monitor ocean conditions and understand ecosystems, make sure to find a moment to reflect on the skills that you are developing to allow you to tackle these tasks. These are the skills that you will take with you along your educational journey and pathway into the workplace.

They also happen to be the skills that are in high demand by employers around the globe. Machine learning, data analytics, AI, video marketing, critical thinking, creativity, collaboration, time management, and leadership – articles published by [LinkedIn](https://www.linkedin.com/) and [Forbes Magazine](https://www.forbes.com/) highlight these technical and employability (aka “Soft”) skills as the most “in-demand for the next 10 years” and, likely, beyond.

A number of these skills could be described as “entrepreneurial,” part of a skill set that also includes the ability to understand the breadth of business operations (from using data to make informed financial decisions to researching and critiquing potential design solutions and producing content for media outreach); acknowledge your strengths (and weaknesses!); work as an integral part of a team; and apply technical knowledge and skills in new and

creative ways. By developing a business acumen, a mindset for innovation and collaboration, and an understanding of how to take environmental, social, and governance (ESG) factors into consideration when making business decisions, you will be well prepared for the global workplace and ready to tackle today's (and tomorrow's!) challenges.

As you read through this manual you will see the following icons:*



These icons correspond to the employability (orange) and ROV-specific (green) knowledge and skills that you gain as you build your ROV and prepare for the competition and which of the various competition requirements – from Product Demonstration to Engineering and Communication – help to develop each of these skills.

**These icons are from Evaluate-Compete, which is designed to help give you a competitive edge in preparing for the competition and the workforce! High school and college teams are invited to participate in the projects pilot testing phase. Visit [Evaluate-Compete](#) for more information.*

THINK OF YOURSELVES AS ENTREPRENEURS

The MATE ROV Competition not only encourages you to reflect on the skills that you develop, but, for more than a decade, has also challenged you to think of yourself as an entrepreneur, embrace the skills that being one requires, and transform and organize your team into a start-up company. Use the following questions as a guide to assist you with this process:

- What is your company name?
- Who are its leaders, including the:
 - CEO (chief executive officer – the leader)
 - CFO (chief financial officer who oversees the budget and spending)
- Who manages Government and Regulatory Affairs (i.e. who's in charge of reviewing the competition rules and making sure that they are understood and followed by everyone)?
- Who is responsible for research and development (aka R&D)?
- Who is responsible for system(s) engineering? Design integration? Testing? Operations?
- Who is responsible for fund-raising, marketing, and media outreach?
- Who is the company's ESG research and engagement analyst?
- What other positions might you need? (Depending on your personnel resources, more than one person may fill more than one role.)
- What products and services do you provide?

- Beyond MATE, who are your potential clients?

10 CHALLENGES – 10 YEARS – ONE OCEAN

In short, the **MATE ROV Competition’s philosophy** is about student learning. It is about the knowledge and skills gained through participating in the competition and how that knowledge and those skills prepare you for your future career in the ocean STEM workforce – and [beyond](#).

As you contemplate your future education and career plans, the challenge presented to you today is how to apply your knowledge and skills to addressing the competition mission tasks so that we can effectively consider and respond to the question “how do we move from the ocean we have to the ocean we want?”

Again this year the MATE ROV Competition is highlighting the [United Nations Decade of Ocean Science for Sustainable Development](#) and aligning its mission tasks with the “10 Challenges for Collective Impact”. This 2025 MATE ROV Competition also continues to inspire ESG principles in order to do “good for good” for our ocean planet and global community. Again this MATE ROV Competition season the “client” is us – our global community of learners, inspired by the ocean, innovating and collaborating to address societal challenges. You are presented with a request for proposals (RFP), the specifics of which are included below.

PART 1: PRODUCT DEMONSTRATION



OVERVIEW

NAVIGATOR class companies will take part in ONE product demonstration that consists of three distinct tasks:

TASK #1: Shipwrecks, Spotter Buoys, and Flying Fish: Documenting the Impact of Climate Change and Invasive Species on the Great Lakes

TASK #2: Marine Renewable Energy: Producing Power from Our Planet While Monitoring Environmental Impact

TASK #3: MATE Floats!

NOTE: Regional competitions may not include all 3 tasks of the product demonstration; regional competitions may also give companies more than one attempt at the product demonstration. If competing at a regional event, [contact your regional coordinator or visit your regional contest’s website](#) to determine what will take place at your regional

competition. Regardless, the product demonstration score will be added to your [ENGINEERING & COMMUNICATION](#) and [SAFETY](#) scores to determine your total, overall score for the competition.

SCORING OVERVIEW

The competition consists of product demonstrations, engineering and communication, and safety with the following scoring breakdown:

- **Product demonstrations**
 - 265 points (max), plus a time bonus
 - Product demonstration organizational effectiveness
 - 10 points (max)
- **Engineering & Communication**
 - Technical documentation
 - 50 points (max)
 - Engineering presentations
 - 50 points (max)
 - Marketing displays
 - 50 points (max)
 - Company Spec Sheet
 - 20 points (max)
 - Corporate Responsibility
 - 20 points (max)
- **Safety** – 10 points (max)

TOTAL POINTS = 475

NOTE: Regional contests may not require all of the Engineering & Communications components or offer the opportunity to earn points for Corporate Responsibility. If competing at a regional event, [contact your regional coordinator or visit your regional contest's website](#) for more information.

TIME

The time that your company will have to complete the product demonstration will depend on your regional event. Contact [your regional coordinator or visit your regional contest's website](#) to determine how your demonstration will be timed and how long you will have to set up, complete the tasks, demobilize, and exit the station.

At any time during the product demonstration you may pilot your ROV to the surface and remove it from the water for things such as buoyancy adjustments, payload changes, and troubleshooting. However, the product demonstration clock will NOT stop. The only time the clock will stop is if a judge determines that there is an issue that is beyond your control. Otherwise, the clock will only stop after all of the tasks are successfully completed, the ROV has returned to the surface under its own power so that it touches the side of the pool, and a member of your company at the product demonstration station has physically touched the vehicle. Your ROV is not required to return to the surface between tasks.

TIME BONUS

Companies will receive a time bonus for each product demonstration run if you:

- 1) successfully complete the tasks,
- 2) return your ROV to the surface under its own power so that it touches the side of the pool, and
- 3) physically touch your vehicle before the product demonstration time ends.

How the time bonus is calculated will depend on your regional event. Contact your [regional coordinator](#) for more information.

CONTEXT & NEED

As we dive into another MATE ROV Competition season (and our second year as part of the [Marine Technology Society](#)!) we continue to highlight scenarios aligned with the United Nations [Decade of Ocean Science for Sustainable Development \(2021-2030\)](#) while adding a new twist – tackling mission tasks in the Great Lakes!

Rising temperatures, extreme weather, damaged ecosystems, and rising sea levels are affecting all parts of our world, and the Great Lakes are no exception. Home to 84% of North America's surface fresh water and 21% of the world's fresh water, the Great Lakes are one of the world's largest surface freshwater ecosystems. They are becoming ever more threatened as our planet's temperatures continue to rise. We know that our ocean is becoming more acidic as it absorbs carbon dioxide that human activity releases into the atmosphere; studies based on computer models suggest that this same phenomenon may also be happening in big, freshwater systems, such as the Great Lakes. Besides disrupting aquatic life and habitat, acidification could deteriorate the thousands of wooden shipwrecks believed to be resting on the bottom, the majority of which have yet to be discovered.

What impact does a warming, freshwater ecosystem have on these cultural resources? That is an important question for [Thunder Bay National Marine Sanctuary](#) (TBNMS). One of 16 national marine sanctuaries managed by the U.S. [National Oceanic and Atmospheric Administration](#) (NOAA), TBNMS is charged with protecting a significant collection of nearly 100 historic shipwrecks in Lake Huron off the U.S. state of Michigan coast.

The 2025 competition mission tasks challenge you to help answer that question by documenting a shipwreck, installing sensors on a moored buoy for long-term monitoring, and collecting a water sample to measure pH and to detect eDNA to identify the presence (or absence) of an invasive species, which is only compounding the disruptive impacts of climate change on Great Lakes ecosystems. Moving from fresh to saltwater, this year's tasks also require you to maintain offshore wind farms and monitor the impacts of these structures and floating solar panel arrays on organisms that range in size from jellyfish medusa to blue whales. Finally, in 2025, we continue to task you to deploy a vertical profiling float, one that can collect and contribute data to a global repository, enabling us to collectively and collaboratively monitor ocean health.

We launch the 2025 season with continued optimism that together we can inspire, innovate, and create technology solutions to mitigate the impacts of climate change and pave the way to a sustainable future for both our ocean and the Great Lakes. And with the technologies

that enable increased and improved monitoring and data collection to support us, we remain optimistic that we can influence mindsets and guide communities to embrace and adapt practices for the good of us all.

If you have competed in the MATE ROV Competition in the last 4 years, it will come as no surprise that once again this (our 23rd!) competition season the “client” is us: our global community of learners, inspired by the ocean, innovating and collaborating to address environmental and societal challenges. Our 2025 scenarios and mission tasks continue to inspire [ESG](#) and acknowledge and embrace the UN Sustainable Development Goals and its 10 Challenges for Collective Impact,” while also calling attention to the similar climate challenges that are facing freshwater ecosystems.

Again this year we are tasking our MATE competition community to design and build a remotely operated vehicle and the necessary sensors, tooling, and complementary technologies to combat climate change, provide clean energy, protect ecosystems from invasive invaders, and monitor the health of the salt- and freshwater habitats of our Blue Planet. Equipped with scientific data and technology solutions and with an understanding of the actions that we need to take, we can proactively and confidently move from the aquatic ecosystems we have to the ocean, rivers, lakes, and streams we want.

Albeit we won't be able to make that move without an appropriately educated and skilled workforce, one that is aware of and informed about the challenges we face and prepared to apply knowledge and skills to tackling them.

REQUEST FOR PROPOSALS (RFP)

1. General

- a. Mission Task #1: Shipwrecks, Spotter Buoys, and Flying Fish: Documenting the Impact of Climate Change and Invasive Species on the Great Lakes
Ocean Decade Challenges for collective impact:

[**#2: Protect and restore ecosystems and biodiversity**](#)

[**#7: Expand the Global Ocean Observing System**](#)

[**#8: Create a digital representation of the ocean**](#)

In addition to hosting the MATE World Championship, in 2025 the Thunder Bay National Marine Sanctuary (TBNMS) will be celebrating its 25th anniversary as the first national marine sanctuary protecting the maritime history of the Great Lakes. Designated as a sanctuary in 2000, this 4,300-square-mile area of Lake Huron is now both a national marine sanctuary and a state underwater preserve, one of 13 underwater preserves in the state of Michigan.

TBNMS currently looks after nearly 100 shipwrecks, but can easily add to its stewardship as more shipwrecks are discovered. And, given the long history of travel and transport on the Great Lakes, there are more to be discovered. From dugout and birchbark canoes to wooden sailboats and steel freighters, thousands of ships have made millions of voyages across the Great Lakes. The substantial amount of travel over the last 150 years transformed the Great Lakes into one of the world's busiest waterways.

With growth came challenges, particularly before accurate weather forecasting, radar, and GPS assisted ships in steering clear of bad weather, natural obstacles like shoals and shallow

water, and each other. Over 200 pioneer steamboats, tall-masted schooners, and bulky freighters have wrecked near Thunder Bay alone. Discovering these wrecks, identifying and documenting them, sharing their histories, using technology to create ways to explore them (without ever having to get wet!), and ensuring their protection for future generations is core to the mission and role of TBNMS.

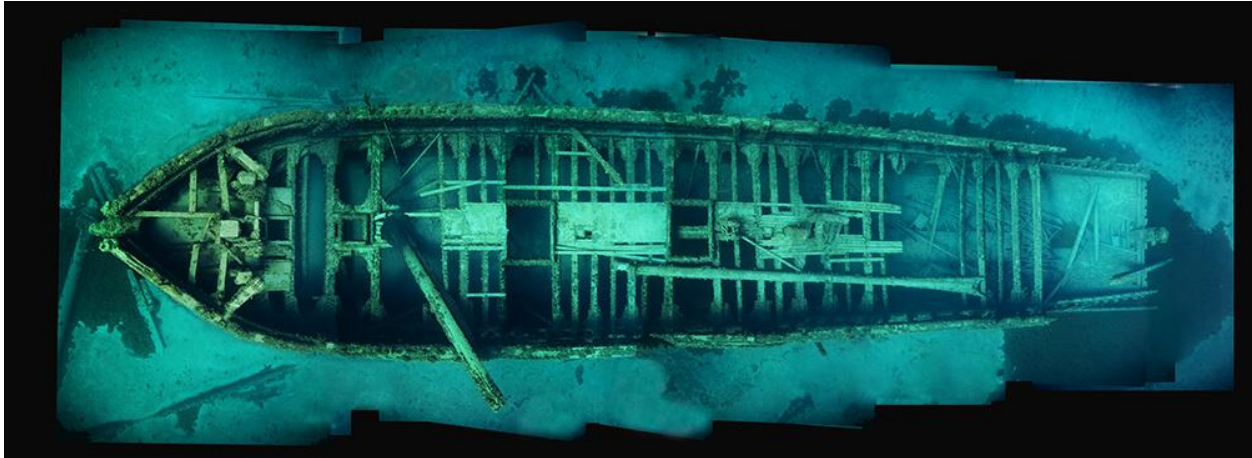

Photomosaic of the wooden two-masted schooner E.B. Allen. ([E.B. Allen | Thunder Bay National Marine Sanctuary \(noaa.gov\)](#))

Making sure that they are protected includes using technology to monitor and track the impacts of rising temperatures and absorption of carbon dioxide and the resulting increase in acidity on these cultural resources. Enter NOAA and Sofar Spotter buoys, moored platforms that have a suite of sensors, both at and below the surface, to collect and transmit data in real time. While NOAA buoys have been operational for more than 10 years, Sofar Spotter buoys are a new addition to Thunder Bay. Low-cost and easy to deploy, Spotter buoys include thermistors (temperature sensors), pressure sensors, and current meters, sensors that measure the partial pressure of carbon dioxide, and more. Together with more traditional technologies (aka researchers in the field) that measure water quality parameters, these buoys are providing access to additional data that will allow us to better understand and evaluate the health of Great Lakes.

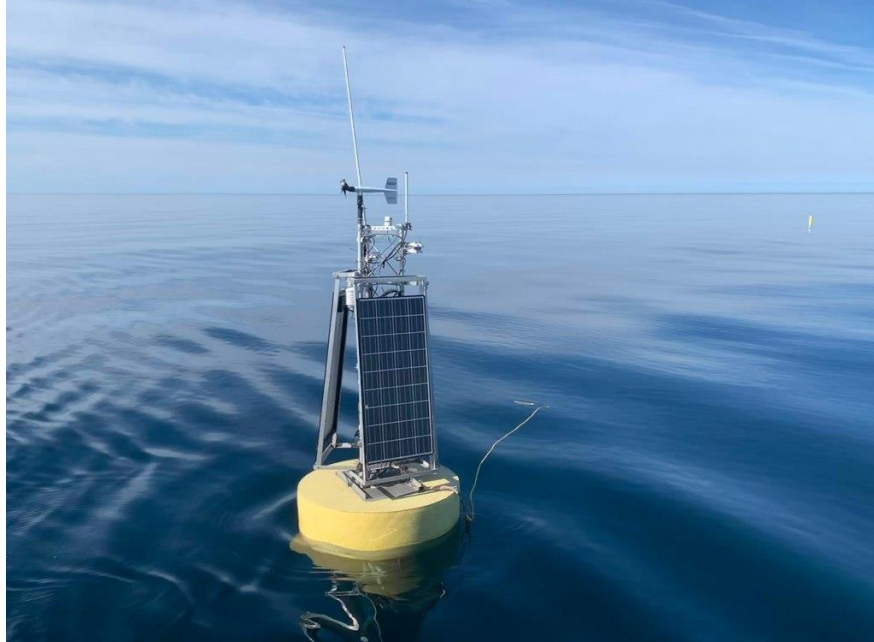

A NOAA buoy in Lake Michigan. ([New science with historic data: 15 years of Great Lakes environmental data archived in NOAA data repository | NOAA Great Lakes Environmental Research Laboratory \(noaaglerl.blog\)](#))

While perhaps not so much a threat to shipwrecks as rising temperatures and acidic conditions, Asian carp are a threat to Great Lakes ecosystems and their \$7 billion fishing industry. Growing up to 100 pounds and four feet in length, these invasive species were originally imported into the southern U.S. in the 1970s to help control algae and parasites in aquaculture ponds and wastewater treatment facilities. Escaping into local rivers, streams, and lakes, Asian carp made their way into the Mississippi River basin and headed north, through the Illinois River watershed and into the Great Lakes where they compete with native fish species for food and space and upset the balance of the lake ecosystem.



Asian carp ([Eat Asian Carp? Sure, why not? Conservation official says they don't taste as fishy - Missouri.net](#))

Enter another technology – environmental DNA, known as eDNA – that allows researchers to monitor and track the carps’ progress through river basins, watersheds, and into the Great Lakes. eDNA technology helps researchers detect and monitor species using DNA fragments shed by organisms in the water column. It involves collecting and processing water samples (and not organisms!) to sequence for DNA, providing a non-invasive, cost-effective, and comprehensive approach to determining the presence (or absence) of species in aquatic ecosystems. Although in the case of invasive species, the hope is NOT to find their DNA in water samples, eDNA is a powerful tool in documenting aquatic biodiversity. Building and expanding an eDNA catalog of the biodiversity of the Great Lakes and the surrounding watersheds will help us to understand – and protect – these ecosystems.

- b. Mission Task #2: Marine Renewable Energy: Producing Power from Our Planet While Monitoring Environmental Impact

Ocean Decade Challenges for collective impact:

[**#2: Protect and restore ecosystems and biodiversity**](#)

[**#4: Develop a sustainable and equitable ocean economy**](#)

Countries around the world are installing offshore wind farms as a way to produce renewable energy and lessen the impacts of climate change. As of June 2024, there were nearly 300 offshore wind farms operating in 20 countries worldwide, with the majority in China. Combine that with the creative minds working to take advantage of existing infrastructure and install floating solar panel arrays amongst offshore wind farms and we arrive at increased efficiency, increased impact, and a powerhouse of technologies producing energy for our planet.

With the installation of offshore wind farms and floating solar panel arrays comes the need to service and maintain the subsea infrastructures. Battling the corrosiveness of saltwater is a priority to maintaining and extending the lifespan of these structures. As any owner of an ocean-going vessel (big or small) knows, zinc, aluminum, and magnesium are “sacrificial anodes” – that is, metals that are more easily corroded than steel, which is what offshore wind structures are typically made of. Attaching a block of zinc to submerged offshore wind structures is a common practice, as is replacing the block with a new one once it’s been significantly “eaten” away. Regularly replacing sacrificial anodes adds life to any structure by reducing and slowing down ongoing corrosion.



Sacrificial anodes attached to a ship's hull ([Sacrificial anodes - Cathwell](#))

Even with sacrificial anodes, corrosion can and does happen. Painting offshore structures with a marine epoxy is a technique used to combat corrosion. As with sacrificial anodes, this epoxy helps to maintain and extend the time that these structures would need to be replaced.

Like offshore oil rigs, offshore wind farms and floating solar panel arrays provide “reef” habitats where diverse groups of marine organisms gather – from fish to invertebrates. Invertebrates in particular thrive; in an otherwise open water environment, these offshore structures offer a hard substrate to attach to, which is essential for many invertebrates. The organisms growing on these reef habitats are key to a diverse ecosystem, and an important part of the marine food web.

Researchers at the Florida Institute of Oceanography are especially interested in studying jellies, including the impact that offshore structures may have on the life cycles of these organisms. One challenge has been to develop the tooling to effectively – and without causing damage – collect the various life cycle stages jellies, from larvae to polyp to adult medusa. Collecting these soft-bodied organisms, in all of their life-cycle stages, is important for understanding the species.

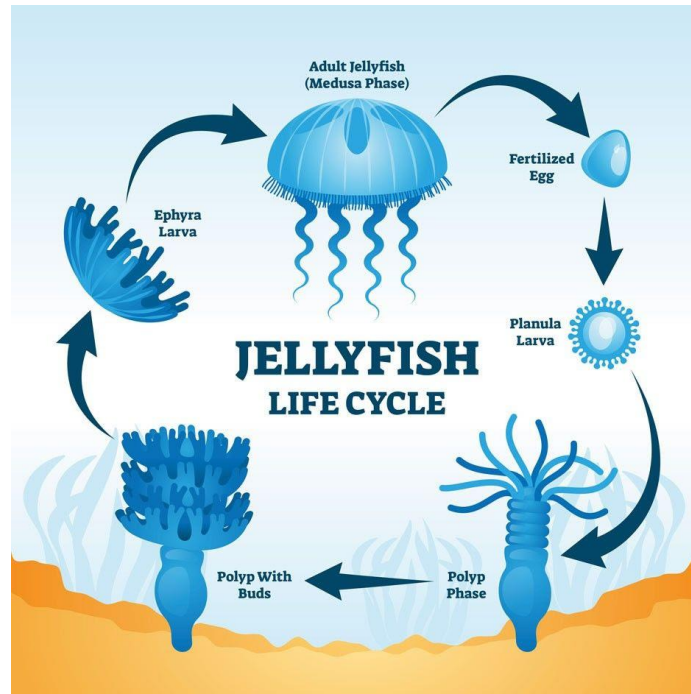

([Jellyfish - Great Barrier Reef Foundation - Great Barrier Reef Foundation](#))

While the subsea infrastructures of offshore wind farms and floating solar panel arrays are benefits for some marine species, they can be obstacles for others. Not only the structures themselves, but the noise produced during pre-construction surveys, installation, operation, and, when the time comes, decommissioning of these structures and its impact on marine mammals is of interest to researchers. One way to monitor both the noise production from and the presence of marine mammals around these structures is by setting up a series of hydrophones on the seafloor. By understanding the amount of noise as well as marine mammals, steps can be taken to lessen any harmful impacts of these offshore marine renewable energy producers, allowing us to save both magnificent species and our beautiful blue ocean planet.

c. Mission Task #3: *MATE Floats!*

Ocean Decade Challenges for collective impact:

[#5: Unlock ocean-based solutions to climate change](#)

[#7: Expand the Global Ocean Observing System](#)

[#8: Create a digital representation of the ocean](#)

The goal of the [National Science Foundation \(NSF\)-funded GO-BGC Project](#) is to build a global network of chemical and biological sensors that monitor ocean health. Scientists, engineers, and technicians from multiple organizations are using NSF grant funds to build and deploy 500 robotic ocean-monitoring floats around the globe. The temperature, depth, and bio-geochemical information that these floats collect will add to the data needed to better understand ocean processes and predict the consequences of climate change. As of November 2024, more than 200 GO-BGC floats have been deployed throughout the global ocean.

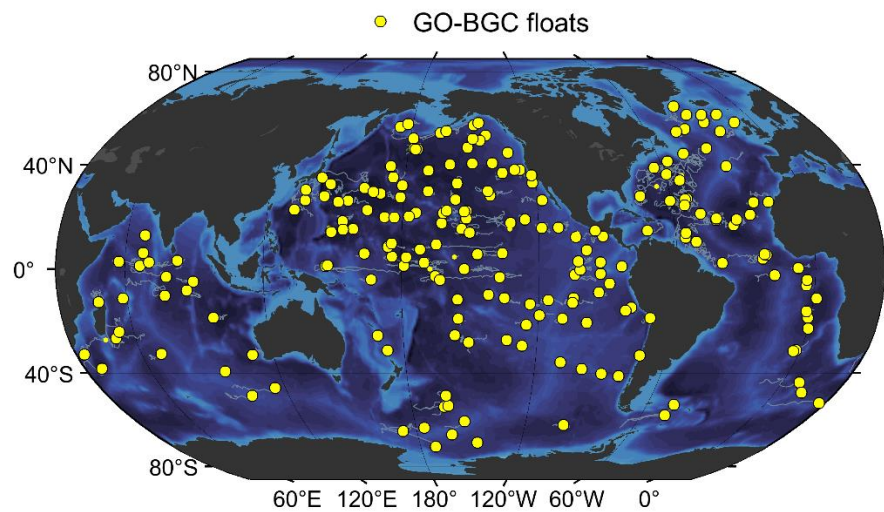

Non-operational floats denoted by small circles [05-Nov-2024]

GO-BGC Float locations as of November 5, 2024 ([Array Status | GO-BGC](#)).

These GO-BGC floats have joined a larger network of vertical profiling floats that have been circulating the world ocean for more than 20 years. Named after the ship made famous by Jason of Greek mythology, the [Argo float program](#) is an international effort of 30+ countries that since 1990 has deployed nearly 4,000 floats to collect temperature and salinity data and make this data available to the global community of researchers, changing the way we learn and share information about the ocean. GO-BGC floats are essentially the next generation of Argo floats and represent a technological evolution with the development and addition of bio-geochemical sensors – and, most importantly, making the data that these sensors collect available to the broader science community.

The MATE ROV Competition's primary focus is on engineering ROVs. However, the GO-BGC project provides an opportunity to present competitors with the challenge of designing and building another type of underwater technology, one that contributes to ocean observations and research that is critical to understanding the impact of climate change.



Readying a GO-BGC float for deployment ([GO-BGC | Global Ocean Biogeochemistry Array](#))

2. Mission Scope and Purpose

This and the following sections contain the technical specifications and requirements for ROV services needed to support the **UN Decade of the Ocean, MATE Year of the Great Lakes: Monitoring and Mitigating the Impacts of Climate Change on Our Water World**. In 2025, ROV services include:

1. Task 1. Shipwrecks, Spotter Buoys, and Flying Fish: Documenting the Impact of Climate Change and Invasive Species on the Great Lakes
 - Use visual clues to determine the identity of an unknown shipwreck using type of ship, length of ship, and cargo carried
 - Replace a damaged thermistor on a subsurface Spotter buoy
 - Install a pCO₂ sensor to the subsurface Spotter buoy
 - Collect a water sample
 - Measure the pH and dissolved CO₂ levels of the water sample
 - Use eDNA to determine if the unknown sequences include invasive carp
2. Task 2. Marine Renewable Energy: Producing Power from Our Planet While Monitoring Environmental Impact
 - Connect a floating solar panel array to the grid
 - Replace a sacrificial anode on the base of an offshore wind farm
 - Apply a patch to a corroded area on the base of an offshore wind farm
 - Collect polyp stage jellies from underneath the solar panel array
 - Collect a medusa stage jelly from mid-water

- Collect fish species from underneath the solar panel array
 - Place a hydrophone in the designated location
3. Task 3. *MATE Floats!*
- Prior to the competition, design and construct an operational profiling float
 - Float completes a vertical profile
 - Float collects temperature data
 - Data graphed as temperature versus depth
3. Specifications
- See the specific tasks described below as well as the [VEHICLE DESIGN & BUILDING SPECIFICATIONS](#) and [COMPETITION RULES](#) sections.
4. Maintenance and Technical Support
- The company shall warrant the ROV and associated systems and equipment for at least the duration of the product demonstrations. Repair or replacement shall be at the company's expense, including the cost of shipping the ROV to and from the competition facility.
- During regional events, the company shall provide at least one day of technical support to resolve hardware, software, and operational issues.
5. Shipping and Storage
- Delivery of the ROV and associated systems and equipment shall be no later than the date of the geographically closest regional contest.
6. Evaluation Criteria
- a. Technical documentation
 - b. Engineering presentation
 - c. Marketing display
 - d. Company spec sheet
 - e. Product demonstration
 - f. Safety
7. References
- a. General
 - [United Nations Decade of Ocean Science for Sustainable Development](#)
 - [17 UN Sustainable Development Goals](#)
 - [10 Challenges - Ocean Decade](#)
 - [A Hotter Future Is Certain, Climate Panel Warns. But How Hot Is Up to Us](#)
 - [ESG \(environmental, social and governance\)](#)
 - [Here's What Climate Change Is Doing to the Great Lakes](#)
 - [Great Lakes Facts and Figures](#)
 - [Scientists: Atmospheric carbon might turn lakes more acidic](#)
 - b. Task 1: Shipwrecks, Spotter Buoys, and Flying Fish: Documenting the Impact of Climate Change and Invasive Species on the Great Lakes
 - [Frozen in Time: National Marine Sanctuary Researchers Discover Lost Shipwreck Ironton](#)

- [Thunder Bay National Marine Sanctuary \(noaa.gov\)](https://www.noaa.gov)
- [Shipwrecks | Thunder Bay National Marine Sanctuary](#)
- [3DShipwrecks.org](https://www.3DShipwrecks.org)
- [Spotter Platform - Subsurface](#)
- [Great-Lakes Region Acidification Research](#)
- [Freshwater Acidification Research in Thunder Bay Great Lakes Fishery Commission - Invasive Carps](#)
- [What are Invasive Carp?](#)
- [New Study Finds Asian Carp Threat to Lake Michigan Is Greater Than Previously Thought](#)
- [Environmental DNA Technology Committee](#)
- [Exploration Tools: Environmental DNA: NOAA Office of Ocean Exploration and Research](#)
- [Deep Trouble: In hunt for Asian carp, scientists find DNA, controversy](#)
- [How eDNA technology is changing the game for protecting ocean species Location of the Illinois River basin](#)

c. Task 2: Marine Renewable Energy: Producing Power from Our Planet While Monitoring Environmental Impact

- [Top 10 Things You Didn't Know About Offshore Wind Energy](#)
- [What are the advantages and disadvantages of offshore wind farms?](#)
- [Offshore wind farms by key country 2024](#)
- [A metaheuristic optimization model for the inter-array layout planning of floating offshore wind farms](#)
- [Wind turbine design – Corrosion control challenges](#)
- [Singapore unveils one of the world's biggest floating solar panel farms](#)
- [Where the Sun Meets the Sea: Offshore Floating-PV Powers Singapore's Journey Toward Carbon Neutrality](#)
- [RWE And SolarDuck To Explore And Develop Offshore Floating Solar Parks Globally](#)
- [Jellyfish and Comb Jellies](#)
- [Wind Turbine – Discovery of Sound in the Sea](#)
- [Recent Advances in Autonomous Environmental Monitoring Technologies to Support Offshore Wind Energy](#)

d. Task 3: *MATE Floats!*

- [GO-BGC | Global Ocean Biogeochemistry Array](#)
- [Expanding Fleet of Autonomous Floating Robots Targets Deeper Understanding of Global Ocean Dynamics](#)
- [2021 MATE Floats! | MATE ROV Competition Website](#)
- [Adopt-a-Float Newsletters | GO-BGC](#)

SIZE RESTRICTIONS

None: NAVIGATOR class companies are not restricted on the size of their vehicle. Companies must be able to transport the vehicle and associated equipment to the product demonstration station and to the engineering presentation area by hand. ROV systems must be capable of being safely hand launched.

PRODUCT DEMONSTRATION

IMPORTANT NOTE: Questions about the competition, production demonstrations, and design and building specifications should be posted to the [MATE ROV Competition Forum Board](#). Questions will be answered by MATE ROV Competition officials so that all companies can see the questions and answers. This will also help to avoid duplicate questions. That said, please make sure that your question(s) has not already been asked – and answered – before posting. It is up to you and your company to read, comprehend, and comply with ALL rulings posted on the site. All pertinent rulings will be posted to the [2025 Official Rulings](#) thread, which will be pinned to the top of the forum board.

ORGANIZATIONAL AND OPERATIONAL EFFECTIVENESS

Companies will receive up to 10 points for Organizational and Operational Effectiveness. This includes points for teamwork, collaboration and communication, project management, problem solving and the ability to deal with obstacles, and system design and control.

Organizational and operational effectiveness is included on the product demonstration rubric posted [here](#). This rubric will be posted by March 1, 2025. In the meantime, companies may refer to the [previous year's rubrics](#) for a general idea of the categories and points.

TASK 1: Shipwrecks, Spotter Buoys, and Flying Fish: Documenting the Impact of Climate Change and Invasive Species on the Great Lakes

This task involves the following steps:

Task 1.1 Shipwrecks

- **Use visual clues to determine the identity of an unknown shipwreck**
 - **Determine type of ship – 5 points**
 - **Determine length of ship**
 - **Within 5 cm – 10 points**
 - **Between 5.01 cm and 10 cm – 5 points**
 - **Not within 10 cm – 0 points**
 - **Determine the cargo that the ship carried**
 - **Remove the cover and determine the type of cargo – 5 points**
 - **Replace the cover – 5 points**
 - **Identify the shipwreck – 10 points**

Task 1.2 Spotter Buoys

- **Replace a damaged thermistor on the subsurface Spotter buoy**
 - **Remove the damaged thermistor**
 - **Release the top end connection point – 5 points**
 - **Release the bottom end connection point – 5 points**
 - **Install a new thermistor**
 - **Attach the top end connection point – 10 points**

- **Attach the bottom end connection point – 10 points**
- **Install a pCO₂ sensor to the subsurface Spotter buoy – 10 points**

Task 1.3 Lake Acidification and Invasive Carp

- **Collect a water sample – 10 points**
 - **Lake acidification**
 - **Determine the pH of the water sample – 5 points**
 - **Measure the dissolved CO₂ levels of the water sample – 5 points**
 - **eDNA of invasive carp**
 - **Determine if the unknown sequences include invasive carp – 10 points**

Total points = 105 points

Product Demonstration Notes:

Task 1.1 Shipwrecks

An unknown shipwreck will be located on the bottom of the pool. The shipwreck will be constructed from ½-inch PVC pipe. Depending on the type of ship, the shipwreck may also be constructed from rope, plastic sheeting, and/or other materials. Companies must use visual clues to determine the identity of the unknown shipwreck. A shipwreck handbook (see [PRODUCT DEMONSTRATION RESOURCES](#)) will be available at the product demonstration station. The shipwreck handbook will include 9 unknown shipwrecks; the shipwreck located on the bottom of the pool will match one of these shipwrecks. Each of the 9 shipwrecks in the handbook will have unique factors to set it apart from other shipwrecks.

Companies must determine the type of ship. The shipwreck will either be a sailing schooner, a steam-driven paddlewheel ship, or a propeller-driven bulk freighter. Sailing schooners will be identified by a mast. Masts will be constructed from ½-inch PVC pipe and painted brown. Steam driven paddlewheel ships will be identified by an octagonal paddlewheel. Paddlewheels will be constructed from ½-inch PVC pipe. Propeller driven bulk freighters will be identified by a propeller. Propellers will be constructed from ½-inch PVC pipe with corrugated plastic attached to it. Companies will receive 5 points for successfully determining the type of ship. Successfully determining the type of ship is showing the station judge the shipwreck's mast, paddlewheel, or propeller on a video display and verbally communicating the type of ship to the judge.

Companies must measure the length of the shipwreck from bow to stern. Both the bow and the stern of the shipwreck will rise approximately 20 cm above the bottom of the pool. The measurement must be taken from the very front of the ½-inch PVC rising at the bow of the shipwreck to the very back of the ½-inch PVC rising at the stern of the shipwreck. Companies should verbally communicate their length measurement to the station judge. If companies are calculating the total length from a given distance, that should also be verbally communicated to the station judge. Companies will receive 10 points if their measurement is within 5 cm of the true length of the shipwreck. Companies will receive 5 points if their measurement is between 5.01 and 10 cm of the true length of the wreck. Companies will receive 0 points if their measurement is greater than 10 cm from the true length. Companies will only have one chance to correctly measure the length of shipwreck.

Shipwrecks in the Great Lakes are historical sites and must be preserved. Therefore, companies will be penalized 5 points each time their ROV comes in contact with the

shipwreck, up to penalty of 25 points total. This includes the ROV tether and other components, but does not include the profiling float, which acts independently once released. If any part of the ROV comes in contact with the shipwreck, the station judge will inform the company, and the company will be penalized 5 points.

Companies must determine the type of cargo carried by the ship. The cargo container will be constructed from a [Sterilite 6 qt plastic container](#) with a lid that will act as a cover. The container will be painted brown so the contents cannot be seen from the outside. A ½-inch PVC handle will act as a carrying mechanism for the cover. Companies must first remove the cover from the cargo container. The cover will not be secured to the container; the cover will be weighted and resting on top of the cargo container. The cargo will be constructed from ½-inch PVC tees and 90° elbows painted a certain color. Yellow tees and elbows represent wheat. Red tees and elbows represent bricks. Black tees and elbows represent coal. White tees and elbows represent furnace sand. Note: the cargo container and cover are not considered part of the shipwreck and may be contacted by the ROV without penalty.

Companies will receive 5 points for successfully removing the cover and determining the type of cargo. Successfully removing the cover is defined as the cover no longer in contact with any portion of the cargo container. Successfully determining the type of cargo is showing the station judge the exposed cargo and verbally communicating to the station judge the type of cargo: wheat, bricks, coal, or furnace sand. Companies must have successfully removed the cover in order to identify the cargo.

The lid will weigh less than 5 Newtons in water.

Once the cover has been removed and the cargo identified, companies must replace the cover, leaving the shipwreck as they discovered it. Companies will receive 5 points for successfully replacing the cover on the cargo container. Successfully replacing the cover is defined as the cover no longer in contact with the ROV, resting on top of the cargo container, and no part of the cover in contact with the bottom of the pool. The cover does not have to fully conceal the cargo inside. Companies must show the station judge the cover on the cargo container in a video display. The cover must stay on the cargo for the entire product demonstration run. If the cover is knocked off at any time during the product demonstration run, companies will lose their points for replacing the cover. If these points are lost, companies may attempt to replace the cover again to regain those points.

Companies then must identify the shipwreck. Companies must have determined the type of ship, the length of the ship (even if incorrectly measured), and the cargo of the ship to identify the shipwreck. (Note: The cover does not have to be replaced over the cargo to identify the shipwreck.) When all three factors have been determined, companies may consult the shipwreck handbook located at the station to identify the ship.

Companies will receive 10 points for successfully identifying the shipwreck. Successfully identifying the shipwreck is defined as verbally communicating to the station judge the name of the shipwreck and confirming that the three factors visually match with that shipwreck information. For example, if the company determines the ship is a paddlewheel ship, the length is 1.56 meters, and the cargo was wheat, they could consult the shipwreck handbook and identify the ship as the *Albany*.

Task 1.2 Spotter Buoys

A Spotter buoy will be located in the pool at the start of the product demonstration. The Spotter buoy will consist of a float at the surface constructed from a 2-inch tee and foam, a mid-water thermistor constructed from 1 ½-inch, 1-inch and ½-inch PVC pipe, and a base, on the bottom, constructed from 1 ½-inch and ½-inch PVC pipe. A [#310 U-bolt](#) will act as a carrying mechanism for the thermistor. A rope will connect the surface, mid-water, and bottom base of the Spotter buoy. A new thermistor, constructed identically to the one located on the Spotter Buoy in mid-water, will be on the surface, side of the pool.

Companies must replace the damaged mid-water thermistor on the Spotter buoy. The thermistor will be connected by Velcro to two 1 ½-inch end caps, one of which will hang down below the surface Spotter buoy, the other which will have flotation attached and rise up from the base of the Spotter buoy. Companies must release the damaged thermistor by pulling down to release it from the top end cap, and by pulling up to release it from the bottom end cap.

Companies will receive 5 points for successfully releasing the top end Velcro connection and 5 points for successfully releasing the bottom end connection point. Successfully releasing from the top connection point is defined as no part of the damaged thermistor touching the top end cap. Successfully releasing from the bottom connection is defined as no part of the damaged thermistor touching the bottom end cap. Companies may release either end of the damaged thermistor first; the two releases may be done in any order. The damaged thermistor is considered debris; companies must return the damaged thermistor to the surface or it must be under control of their ROV at the end of the product demonstration run.

Once the damaged thermistor has been removed from both connection points, companies may install the new thermistor by attaching it to both the top and bottom end connection points. The new thermistor will be located on the surface, side of the pool at the start of the product demonstration run.

Companies will receive 10 points for successfully attaching the new thermistor to the top end connection point. Successfully attaching the new thermistor to the top end connection point is defined as a Velcro to Velcro stick from the Velcro loops at one end of the thermistor to the Velcro hooks on the inside of the 1 ½-inch end cap. Companies will receive an additional 10 points for successfully attaching the new thermistor to the bottom end connection point. Successfully attaching the new thermistor to the bottom end connection point is defined as a Velcro to Velcro stick from the Velcro loops at one end of the thermistor to the Velcro hooks on the inside of the 1 ½-inch end cap. Companies may connect to either the top end or bottom end first; the two connections may be done in any order. Once installed, the thermistor must remain installed for the entire product demonstration run. If the thermistor becomes disconnected from the top and/or the bottom connection point, companies will lose their points for attaching to that connection point. Companies may attempt to reattach to the connection point to regain those points.

Companies must also install a pCO₂ sensor at the base of the Spotter buoy. A pCO₂ sensor will be available at the surface, side of the pool at the start of the product demonstration run. The pCO₂ sensor will be constructed from ½-inch PVC. A length of [rope](#) will act as a carrying mechanism for the pCO₂ sensor. Companies must install the pCO₂ sensor into a port on the

base of the Spotter buoy. The base of the Spotter buoy will be constructed from ½-inch PVC pipe; the port will be constructed from 2-inch pipe with a 3-inch to 2-inch reducer.

Companies will receive 10 points when they successfully install the PCO₂ sensor into the port on the base of the Spotter buoy. Successfully installing the PCO₂ sensor is defined as the sensor no longer in contact with the ROV and inside the 3-inch to 2-inch reducer. The PCO₂ sensor must remain in the reducer for the entire product demonstration run. If the pCO₂ sensor comes out of the reducer at any time during the product demonstration run, companies will lose points for installing it. If it does come out, companies may install it again to regain those points.

Task 1.3 Lake Acidification and Invasive Carp

Companies must collect a water sample. The water sample will be simulated by a 1 ½-inch pipe with end caps. A length of [rope](#) will act as a carrying mechanism for the water sample. Companies will receive 5 points for successfully collecting the water sample. Successfully collecting the water sample is defined as the 1 ½-inch PVC pipe placed on the surface, side of the pool.

Once the water sample has been collected, companies may open an end cap of the sample and retrieve two plastic test tubes from inside. One test tube will be marked pH; the other will be marked CO₂.

Companies must measure the pH of the water in the test tube marked pH. MATE will supply a [litmus strip pH test](#) to determine the pH of the sample. Companies may choose to bring and use their own pH sensor or test kit as well.

Companies will receive 10 points when they successfully determine the pH of the water sample. Successfully determining the pH of the sample is defined as showing the mission station judge the pH reading and verbally communicating to the judge whether the sample is acidic or alkaline. An acidic reading is defined as a reading from 0.1 to 7.0. An alkaline reading is defined as a reading from 7.01 to 14.

Companies must also measure the dissolved CO₂ levels of the water in the test tube marked CO₂. Companies will use a [commercial carbon dioxide](#) test kit to determine the dissolved CO₂ levels of the water sample. The test kit will include all the components needed to complete the testing, including a test tube, reagents, and titrator. The process for testing is detailed in the dissolved CO₂ Test Procedure, which can be found in the [PRODUCT DEMONSTRATION RESOURCES](#). This procedure includes a video.

Companies will receive 10 points when they successfully measure the dissolved CO₂ levels of the water sample. Successfully measuring the dissolved CO₂ levels is defined as showing the station judge that the sample has turned pink and verbally communicating the amount of reagent (CO₂ B) used to turn the sample pink. The sample must maintain color for 10 seconds after mixing.

Once the water sample has been successfully collected, companies will receive laminated sheets with ten eDNA code sequences representing unknown organisms. Companies must compare the unknown DNA sequences to those of the invasive carp species. The Invasive Carp Species Handbook will be available at the product demonstration and will include two

DNA sequences of the two invasive carp species. See the [PRODUCT DEMONSTRATION RESOURCES](#) to access the handbook. Companies must compare the ten unknown DNA sequences to the invasive carp species sequences.

Companies will receive 10 points for successfully determining if the unknown sequences include invasive carp. Successfully determining if the unknown sequences include invasive carp is defined as verbally communicating to the station judge which unknown sample matches that of one species of invasive carp. Only one of the ten unknown samples will correspond to one of the invasive carp species. Companies must verbally communicate to the station judge which unknown DNA sequences match one of the two DNA sequences of the invasive carp species.

Dissolved CO₂ testing, pH testing, and identifying invasive carp may be done in any order. Companies can test for pH, test for dissolved CO₂, and identify invasive carp in any order they choose.

TASK 2: Marine Renewable Energy: Producing Power from Our Planet While Monitoring Environmental Impact

This task involves the following steps:

Task 2.1 Produce Power

- **Connect a floating solar panel array to the grid**
 - **Retrieve the power connector – 5 points**
 - **Install the power connector into the hub**
 - **Remove the cover from the connection port – 5 points**
 - **Install the connector – 10 points**
- **Protect an offshore wind farm from corrosion**
 - **Replace a sacrificial anode onto the base of an offshore wind farm**
 - **Disconnect the old sacrificial anode from the base – 5 points**
 - **Connect the new sacrificial anode onto the base – 10 points**
 - **Mitigate corrosion**
 - **Conduct a visual inspection of the base structure – 5 points**
 - **Apply an underwater epoxy patch to the corroded area – 10 points**

Task 2.2 Monitor Environmental Impact

- **Collect life stages of jellyfish**
 - **Collect polyp stage jellies attached to the solar panel array**
 - **Collect 4 or more polyps – 10 points**
 - **Collect 1 to 3 polyps – 5 points**
 - **Collect a medusa stage jelly from mid-water**
 - **Collect the medusa jelly – 15 points**
- **Collect fish species aggregated underneath the solar panel array**
 - **Collect 4 or more fish species – 10 points**
 - **Collect 1 to 3 fish species – 5 points**
- **Place a hydrophone in the designated location**
 - **Place the hydrophone in the designated location – 10 points**
 - **Pull the pin to release the hydrophone from its base – 5 points**

Total points = 100 points

Product Demonstration Notes:

Task 2.1 Produce Power

Companies must connect a floating solar panel array to the grid. The floating solar array panel will be on the surface adjacent to an offshore wind turbine. A [rope](#) will connect the surface components of the floating solar panel array to a platform with a connector on the bottom of the pool. A 4-meter wire will connect the platform to the connector. A [rope](#) will connect the surface components of the wind turbine the base structure of the wind turbine on the bottom of the pool. The surface components of the floating solar panel array and the wind turbine will be constructed from ½-inch PVC pipe and corrugated plastic sheeting. The platform of the solar panel array on the bottom of the pool will be constructed from ½-inch PVC pipe and corrugated plastic sheeting. The base structure of the wind turbine will be constructed from ½-inch, 1-inch, and 2-inch PVC pipe, and corrugated plastic sheeting.

To connect the floating solar panel array to the grid, companies must retrieve the power connector, remove the cover from the connection hub, and install the connector into the power port. The power connector will be located on a platform on the bottom of the pool. The power connector will be constructed from ½-inch PVC. A [#6 screw hook](#) will act as a carrying mechanism for the power connector. Wire will connect the power connector to the platform.

Companies will receive 5 points for successfully retrieving the power connector from the platform. Successfully retrieving the power connector is defined as the power connector under control of the ROV and no longer touching the platform or the bottom of the pool.

Companies must also remove the cover from the connection port. Companies may remove the cover from the connection port before or after they pick up the power connector. The connection port will be constructed from 2-inch PVC pipe. The cover of the connection port will be constructed from a 3-inch PVC end cap. A length of [rope](#) will act as a carrying mechanism for the cover.

Companies will receive 5 points when they successfully remove the connection cover from the connection port. Successfully removing the connection cover is defined as the cover under control of the ROV and no longer in contact with connection port. The connection cover is considered debris; companies must return the cover to the surface or under control of their ROV at the end of the product demonstration run.

Once the power connector has been retrieved and the cover removed from the connection port, companies must install the connector into the port. The end of the connector will be covered by Velcro hooks. The inside of the port will covered by Velcro loops.

Companies will receive 10 points when the connector is successfully installed into the port. Successfully installing the connector is defined as the connector no longer in contact with the ROV, the connector inserted into the 2-inch port, and the connector making a Velcro-to-Velcro stick. Once installed, the power connector must remain installed for the entire product demonstration run. If the connector becomes disconnected, companies will lose

their points for installing the connector. Companies may attempt to reinstall the power connector to regain those points.

Companies must replace a sacrificial anode on the subsurface base structure of the offshore wind farm. Both the old and the new sacrificial anode will be constructed from 2-inch and ½-inch PVC pipe. Both anodes will be painted silver. To replace the sacrificial anode, companies must first disconnect and remove the old sacrificial anode. Once removed, companies must connect the new sacrificial anode and secure it in place. A section of ½-inch PVC pipe will be inserted through a slot cut in the corrugated plastic sheeting. At the start of the product demonstration, this section of ½-inch PVC pipe will be located underneath the slot in the plastic sheeting. Disconnecting and removing the sacrificial anode requires turning the anode so the ½-inch PVC pipe is parallel to the slot in the plastic sheeting and can be removed through the slot. Companies may rotate the anode in either direction to disconnect and remove it.

Companies will receive 5 points for successfully disconnecting and removing the old sacrificial anode from the base structure of the offshore wind farm. Successfully disconnecting and removing the sacrificial anode is defined as the old sacrificial anode under control of the ROV and no part of it touching the base structure of the offshore wind farm. The old sacrificial anode is considered debris and must be returned to the surface or under control of the ROV when the product demonstration time ends.

Once the old sacrificial anode is removed, companies must connect the new sacrificial anode and secure it into place. The new sacrificial anode will be available at the surface, side of the pool during the 5-minute set up period. Companies must insert the section of ½-inch PVC pipe through the slot in the corrugated plastic sheeting.

Companies will receive 10 points for successfully connecting the new sacrificial anode onto the base structure of the wind farm. Successfully connecting and securing the new sacrificial anode is defined as the anode no longer in contact with the ROV and the section of the new anode inserted through, and located below, the slot in the corrugated plastic sheeting. Once connected, the new anode must remain connected for the entire product demonstration run. If the anode becomes disconnected, companies will lose their points for connecting the anode to the base structure. Companies may attempt to reconnect the anode to regain these points.

Both the old and new sacrificial anode will weigh less than 10 Newtons in water.

Companies must also mitigate corrosion on the base structure of the offshore wind farm. This involves conducting a visual inspection to identify the area of corrosion and applying an underwater epoxy patch to the corroded area. Companies must first inspect the four “legs” of the base structure for corrosion. Corrosion will be simulated by a [red Velcro hook 1-inch circle](#) on a 1-inch PVC pipe. There will only be one area of corrosion and it will not be on the underside of any of the “legs.”

Companies will receive 5 points when they successfully conduct a visual inspection and identify the corrosion spot. Successfully identifying the corrosion spot is defined as showing the station judge the red Velcro spot on a video display

Once the corrosion has been identified, companies must apply an epoxy patch to the corroded area. The epoxy patch will be available at the surface, side of the pool at the start of the product demonstration run. The epoxy patch will be constructed from a 1 1/4-inch tee cut in half lengthwise and 1/2-inch PVC pipe. The inside of the tee will be covered with Velcro loops.

Companies will receive 10 points for successfully applying the epoxy patch to the corrosion. Successfully apply in the epoxy patch is defined as a Velcro to Velcro connection between the red Velcro hook 1-inch circles and the Velcro loops inside the 2-inch tee. Any Velcro to Velcro connection is considered a successful installation; the patch does not need to cover the entire corrosion area. Once the patch is applied, it must remain applied for the entire product demonstration run. If the patch becomes disconnected, companies will lose their points for applying the epoxy patch. Companies may attempt to reapply the patch to regain those points.

Task 2.2 Monitoring Environmental Impact

Companies must collect life stages of a jellyfish, collect fish species, and place a hydrophone to monitor the environmental impact of offshore energy structures. Companies must collect polyp stage jellies attached to the bottom of a solar panel array. The polyp stage jellies will be constructed from [black chenille pipe cleaners](#). The chenille pipe cleaners will be twisted together into a loop with one end inserted into 3/16-inch holes in the 1/2-inch PVC pipe that is used to construct the offshore solar panel array. Companies must collect the polyp stage jellies and return them to the surface, side of the pool. Companies that successfully collect four or more polyps will receive 10 points. Companies that successfully collect 1 to 3 polyps will receive 5 points. Successfully collecting a polyp stage jelly is defined as the polyp being removed from the PVC framework under control of the ROV and placed on the surface, side of the pool.

Companies must also collect a medusa stage jelly from mid-water. The medusa stage jelly will be simulated by a [water wiggler](#). A 1.5 cm to 2 cm section of 1/2-inch PVC pipe will be inserted into the water wiggler to make it slightly positively buoyant. At the start of the product demonstration run, the medusa stage jelly will be enclosed within a holder constructed from 3-inch pipe. Companies must pull a 1/2-inch PVC pin to remove the top cover of the holder, which will release the jelly into the water. When the cover is removed, the jelly will begin to float to the surface. Once it is in open water, companies must collect the medusa stage. Companies may not apply any direct pressure to the body of the jelly when collecting it; companies should collect the jelly as well as water surrounding the jelly. The jelly may touch the sides of the container, but no additional pressure should be applied to the body of the jelly. Companies may not grab the jelly in a manipulator or squeeze the body of the jelly in any manner.

Companies will receive 15 points for successfully collecting the medusa stage jelly. Successfully collecting the medusa stage jelly is defined as returning the jelly to the surface, side of the pool surrounded by water, without applying any direct pressure to the jelly. Companies should return their entire collection mechanism to the surface, side of the pool. At no time during the product demonstration run should the jelly be removed from the collection mechanism. Companies should either design their collection mechanism to be removed from the vehicle after successfully collecting the jelly or the product demonstration

time should end with the ROV and collection mechanism with the jelly surrounded by water on the surface, side of the pool.

Companies must collect fish species aggregated underneath the solar panel array. Fish species will be simulated by ping pong balls. The ping pong balls will be floating inside a square constructed from ½-inch PVC pipe that represents the floating solar panel array. Companies must collect the fish species and return them to the surface, side of the pool. Companies that successfully collect four or more fish will receive 10 points. Companies that successfully collect 1 to 3 fish will receive 5 points. Successfully collecting a fish is defined as the ping pong ball being removed from PVC square by the ROV and placed on the surface, side of the pool.

Companies must place a hydrophone into a designated location. The hydrophone will be located on the surface, side of the pool at the start of the product demonstration run. The hydrophone will be constructed from 2-inch, 1-inch and ½-inch PVC. The designated location will be a 50 cm x 50 cm square constructed of ½-inch PVC pipe and painted yellow.

Companies will receive 10 points for successfully placing the hydrophone in the designated area. Successfully placing the hydrophone in the designated area is defined as the hydrophone upright and completely within the PVC square. No part of the base of the hydrophone may be on or over the PVC of the designated area. Once placed, the hydrophone must remain upright and within the designated area for the entire product demonstration run. If the hydrophone is knocked over (no longer upright) or is moved from the designated area, companies will lose their points for placing the hydrophone in the designated area. Companies may attempt to return the hydrophone to the upright position or return the hydrophone to the designated area to regain those points.

After placing the hydrophone in the designated area, companies must pull a [pin](#) to release the hydrophone from its base so that it floats in the water column. Companies will receive 5 points for pulling the pin and successfully releasing the hydrophone. Successfully releasing the hydrophone is defined as the 2-inch PVC pipe section of the hydrophone floating above the 3-inch pipe, attached by a rope. Companies must show the station judge on a video screen that the sensor section is floating above the 3-inch pipe. (Note: Companies would not lose points for releasing the hydrophone from its base if the hydrophone is knocked over or moved from the designated area, they would only lose points for placing the hydrophone.)

TASK 3: MATE Floats!

MATE Floats! 2025 is inspired by the National Science Foundation (NSF)-funded GO-BGC Project. The goal of GO-BGC is to build a global network of profiling floats with chemical and biological sensors to monitor circulation, chemistry, biology, and overall ocean health. Scientists, engineers, and technicians are using NSF grant funds to build and deploy 500 robotic ocean-monitoring floats around the globe. As of August 2024, 217 out of the targeted 500 GO-BGC floats have been deployed or will be deployed shortly.

This task involves the following steps:

Design and build an operational vertical profiling float

- **Prior to the competition, design and construct a vertical profiling float with a temperature sensor – 5 points**
- **Float completes a vertical profile – up to 30 points**
 - **Autonomously – 30 points**
 - **Manually – 10 points**
- **Float collects temperature data from four points – up to 20 points**
 - **Air (prior to being deployed) within 4°C – 5 points**
 - **Surface within 4°C – 5 points**
 - **Mid-water within 4°C – 5 points**
 - **Bottom within 4°C – 5 points**
- **Graph temperature versus depth – up to 5 points**

OR

Company does not design and construct a vertical profiling float, or the float does not contain a temperature sensor.

- **MATE-provided data is used to graph depth over time – 10 points**

Total points = 60 points

Product Demonstration Notes:

Prior to the competition, companies must build a float capable of completing a vertical profile (i.e., traveling from the surface to the bottom and back to the surface) and collecting data during the profile.

The vertical profiling float:

- May use a motor and propeller to travel from the surface to the bottom and back. Alternatively, the float may use other means to go up and down, such as a [buoyancy engine](#).
- Propellers must be enclosed inside the frame of the float or shrouded. The propeller should not be able to touch any surface of the pool. Floats with propellers protruding outside the framework will not pass safety inspection and cannot be used.
- Must operate independently of the ROV. The float must go down and up independently of the ROV (on its own).
- May be operated by a pilot. This pilot can be the same person who pilots the ROV or a different pilot. NOTE: Companies that program their float to successfully operate (aka complete a vertical profile) autonomously will receive more points than those who operate their float manually.
- Must be less than 50 centimeters in overall height. The float may not have a diameter/length/width greater than 15 cm.
- MUST operate as a non-ROV device. See below for additional information on powering non-ROV devices.

Companies will receive 5 points for successfully designing and constructing a vertical profiling float. Successfully designing and constructing a float is defined as bringing the profiling float to the mission station and explaining to the judge how it operates (how it moves up and down in the water column).

Companies may deploy their float by hand at the side of the pool.

Once released, the float should attempt to complete a vertical profile. A vertical profile is defined as any part of the float on or above the surface, descending in the water column until any part of the float touches the bottom, then ascending to and breaking the surface once again. Companies may attempt to complete their vertical profile autonomously or manually.

Companies choosing to do their vertical profile autonomously must program their float to complete a single vertical profile. Completing the vertical profile autonomously means using a computer program to control the motor or buoyancy engine. Companies are permitted to manually start the process, but once started the computer program must issue commands to the motor or buoyancy engine to drive the float from the surface to the bottom, and then reverse the motor to drive the float from the bottom back to the surface. Once the float reaches the bottom companies may not manually reverse the motor, that must be done autonomously. Any computer board (Arduino, Raspberry Pi, etc.) controlling the float must be on the surface, side of the pool; any power source for the float must also be on the surface. No electronics or power sources (batteries) are allowed onboard the float.

Companies will receive 30 points for successfully completing a vertical profile autonomously. Successfully completing a vertical profile autonomously is defined as the float on the surface of the pool, autonomously descending to and touching the bottom of the pool, then ascending to the surface again. Companies must inform the judge when their float is at or near the bottom and when it has returned to the surface. Companies must complete an entire vertical profile autonomously, from the surface to bottom to surface without manual input to the float in order to receive points.

Alternatively, companies may manually pilot their float to complete a vertical profile. Companies will receive 10 points for successfully completing a vertical profile manually. Successfully completing a vertical profile manually is defined as a pilot operating the float, and the float starting on the surface, descending to and touching the bottom of the pool, then ascending to the surface again. Companies must complete an entire vertical profile, surface to bottom to surface, to receive points.

Companies must incorporate a temperature sensor on their float to record four temperature measurements. One measurement must be recorded in the air. This measurement must be taken during the mission run before the float is deployed into the water by the ROV. Note that it cannot be taken during the set-up time. A second temperature measurement must be recorded at the surface. The temperature sensor must be underwater, but some portion of the float must be at the surface of the water. A third temperature measurement must be recorded in the midwater. No part of the float should be on or above the surface, no part of the float should be touching bottom. The float does not need to stop in the midwater in order to take the measurement. A sensor providing continuous temperature readings can be used, and a temperature reading recorded when the moving float reaches the midwater. A fourth temperature measurement should be recorded from the bottom of the pool. Some portion of the float must be touching the bottom of the pool. While the profiler completes its vertical profile autonomously, a company member may manually record temperature measurements at the given points in the profile.

Companies will receive 5 points for successfully recording each measurement, up to 20 points. Successfully recording a temperature measurement is defined as showing the station judge your temperature reading and recording that temperature at the mission station. Companies may record the temperatures by hand on paper or enter them into a computer or other device. MATE will not provide paper or a device for recording.

The accuracy of the temperature measurement must be within 4° Celsius of the true temperature. Station judges will have a temperature sensor that will measure the temperature of the pool and the air. Companies can compare their temperature sensor against the station sensor to determine if there is any offset (i.e. to determine if your sensor differs from the station sensor).

Once all four temperature measurements have been recorded, companies must graph those four data points as temperature versus depth. Companies should use the known depth of the pool to estimate the depths for each temperature measurement. For example, in a pool 2.2 meters deep, companies could use 20 cm for their air depth, -10 cm for their surface temperature measurement, -110 cm for their midwater depth temperature measurement, and -220 cm for their bottom temperature measurement.

Companies will receive 5 points when they successfully graph the temperature versus depth. Successfully graphing the data is defined as plotting depth on the Y-axis and temperature on the X-axis and showing the resulting graph to the station judge. All dots should be linked by a line. Companies may use Excel or another computer program to plot their data points or may graph the data points on paper. MATE will not provide computers or graph paper at the mission station; companies must provide their own method for graphing the data. All graphs must have their axes labeled. An example of a graph plotting temperature versus depth is represented below:

Data measured:

Location	Depth (cm)	Temperature (°C)
Air	30	31.4
Surface	-20	27.2
Mid-water	-110	25.5
Bottom	-210	25.4

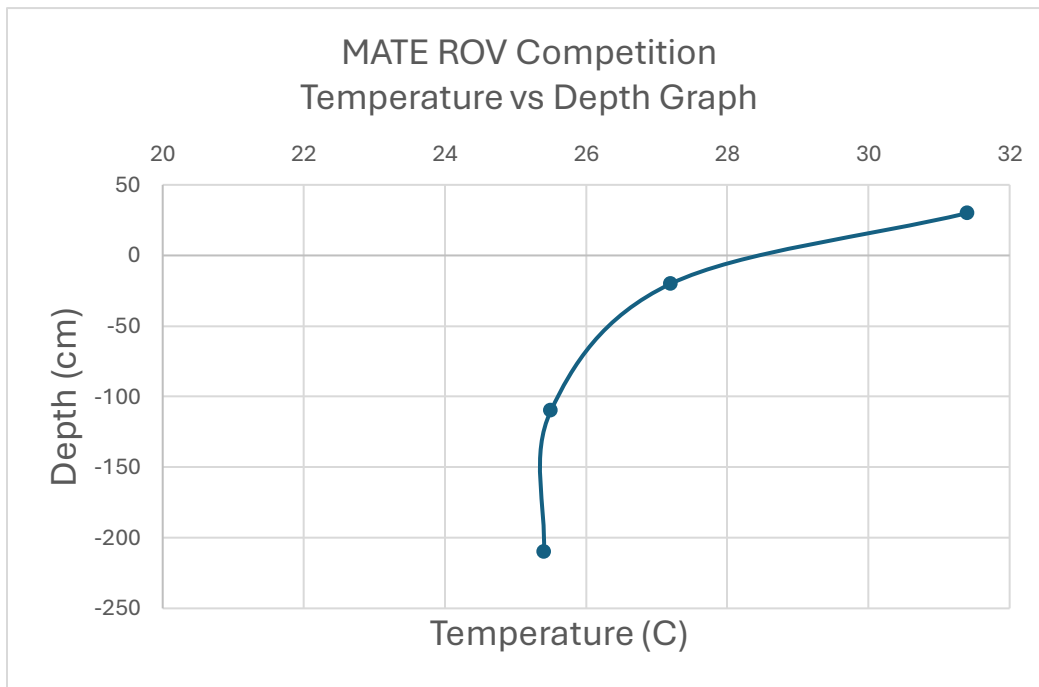

If a company does not build a float, or if the float that they build does not have a temperature sensor, or if the temperature sensor fails to send temperature data back to the mission station, companies should inform the station judge that they are choosing to instead graph data provided by MATE. The judge will then provide a set of ten depth versus temperature data points. Once a company requests the MATE data, they can no longer receive points for collecting four temperatures and graphing those four temperatures. Instead, companies will receive 10 points for successfully graphing depth versus temperature. Successfully graphing the data is defined as showing the station judge a graph with temperature on the X-axis and depth on the Y-axis. All ten data points must be included on the graph. MATE will not provide computers or graph paper at the mission station; companies must provide their own method for graphing the data. All graphs must have their axes labeled.

PRODUCT DEMONSTRATION RESOURCES

Product Demonstration resources can be found on the [Competition Class](#) page.

PRODUCT DEMONSTRATION RESPONSIBILITIES

Companies must design and bring any tools or devices to complete the required MATE product demonstration tasks.

PART 2: PRODUCT DEMONSTRATION PROP BUILDING INSTRUCTIONS & PHOTOS



The [Product Demonstration Prop Building Instructions & Photos](#) will be released with, but separate from, this competition manual.

PART 3: VEHICLE DESIGN & BUILDING SPECIFICATIONS



1.0 GENERAL

IMPORTANT NOTE: Questions about competition, about the production demonstrations and design and building specifications should be posted to the [MATE ROV Competition Forum Board](#). Questions will be answered by MATE ROV Competition officials so that all companies can see the questions and answers. This will also help to avoid duplicate questions. That said, please make sure that your question(s) has not already been asked – and answered – before posting. It is up to you and your company to read, comprehend, and comply with ALL rulings posted on the site. All pertinent rulings will be posted to the [2025 Official Rulings](#) thread, which will be pinned to the top of the forum board.

When emailing their question, companies should reference:

- Any specific specification or rule (e.g. ELEC-002N)
- Competition class

Conventions: All values contained in this document are threshold values unless specifically stated otherwise. All water depths are given in meters (m). All dimensions and measurements utilize SI units.

[Your regional coordinator or your regional contest's website](#), will inform you of any specific requirements or changes for your regional.

2.0 SAFETY

Safety is the competition's primary concern and guiding principle. Any system that is deemed unsafe by competition officials will not be permitted to compete. If a safety concern is identified during the initial inspection, companies are permitted to modify their system and have it re-inspected. Companies are permitted to have their vehicle re-inspected twice. If a company fails to pass its third and final safety inspection, it is disqualified from the underwater competition portion of the event. There are NO APPEALS once an ROV has been disqualified.

NOTE for 2025!!!

MATE ROV Competition safety inspectors will be reinforcing the competition's emphasis on safety. Wiring discipline/workmanship (ELEC-019N) and strain relief at both ends of the tether (ELEC-020N) will be areas of particular emphasis. **Companies that do not meet these safety standards will not be permitted to compete in the in-water events.** Additional examples of wiring workmanship will be included in the [MATE ROV Competition Safety Inspection Tutorial](#). See the [Tech Bulletin – MATE Expected Work Practices](#) for additional information.

Examples of safety violations from previous ROV competitions include:

- Companies used equipment that did not participate in and/or pass safety inspection
- The ROV does not use Anderson Powerpole connectors to attach to main power
- No SID was provided at the safety check
- The ROV does not have a main fuse
- The SID does not show a main fuse
- The ROV used pneumatics, but the technical documentation did not include a pneumatics diagram or pneumatic specifications
- Sharp items, or potentially sharp items, (fishing hooks, glass bottles, mercury thermometers) were included on the vehicle
- The motors were not waterproofed
- Propellers were not shrouded

2.1 Safety Inspection Protocol

1. Before entering the water for practice or a product demonstration run, the ROV system must go through a safety inspection. Once a company successfully passes inspection, they will turn in their safety inspection sheet to the safety inspector and receive a Blue PASSED Card with their company number on it. Companies must present the Blue PASSED Card to the pool practice/product demonstration coordinator before their vehicles are permitted to enter the water.
2. Competition staff will conduct a safety inspection of the vehicle using the [safety inspection rubric](#).
3. If the safety inspector(s) identify a safety violation, companies will have the opportunity to address it. The pool practice or product demonstration run schedule will NOT change to allow companies more time.
4. If during the second safety review the
 - a. violation has not been properly addressed or

- b. another violation is revealed
companies will have ONE additional opportunity to address the issue.
- 5. If during the third safety inspection a violation still exists, safety inspectors will request that the Chief Judge(s) review the violation. If the Chief Judge(s) confirms the violation, companies will not be permitted to participate in the underwater product demonstration component of the competition. However, companies can still participate in the engineering and communication (technical documentation, engineering presentation, and marketing display) component.
- 6. Reminder: All companies must present the Blue PASSED Card to the pool practice or product demonstration judge before placing their vehicles in the water. In addition, product demonstration station judges and competition officials can pause or stop a product demonstration run at any time if they feel that there is a potential safety concern.

Your regional competition may use a system other than a Blue PASSED Card, but all companies must pass a safety inspection before entering the water. Contact [your regional coordinator or visit your regional contest's website](#) to determine if a Blue PASSED Card or another system will be used for safety verification.

Note for 2025!!!

All items used on the ROV MUST participate in and pass safety inspection.

2.1.1 System Interconnection Diagram

To pass the safety inspection, companies must provide a system interconnection diagram (SID) of their vehicle control system. An SID is an electrical diagram of their wiring, including their control box, motors, and any other electrical systems on their vehicle. The SID should separate and show what systems are on the surface and what systems are on the vehicle. The SID must not exceed one page in length. **The diagram MUST show an ROV system fuse. SIDs that do not show a fuse, utilizing an ANSI, NEMA or IEC symbol, with the size of the fuse marked, will not pass their safety check.**

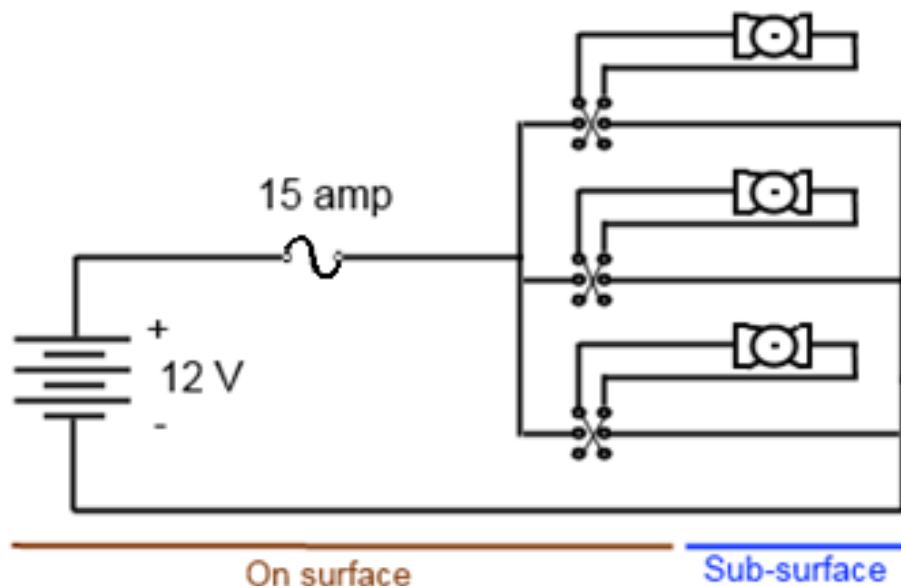

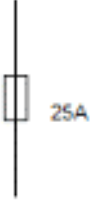

Diagram: An example of an acceptable SID.

Companies should create their own SID. Do not simply copy the above SID, or another SID produced by MATE, including those provided with kits purchased through the SeaMATE store. SIDs help to understand how electricity flows through your system and will provide a better understanding of ROV operations.

DOC-001: Any electrical diagram should use ANSI, NEMA, or IEC symbols as often as possible; it is required for the fuse. They should be neatly hand drawn or created using a CAD software program.

Item	ANSI	IEC
FUSE		

ANSI: American National Standards Institute
 IEC: International Electrotechnical Commission
 NEMA: National Electrical Manufacturers Association

Note: Companies that do not hand draw their SID may use free drawing software such as MS Paint or [OpenOffice](#) to create their diagrams.

2.1.2 Safety Inspection Completed

Companies must complete their safety inspection before entering the water for practice or a product demonstration run on the day of the competition.

3.0 SPECIFICATIONS

The ROV system (or “system”) must meet the following requirements:

3.1 Operational

3.1.1 Multiple Vehicles

OPER-001: MULTIPLE VEHICLES ARE NOT PERMITTED. Companies are required to design and build ONE ROV that can complete the necessary product demonstration tasks. All ROV components, including cameras and payload tools, must be connected to the ROV.

3.1.2 Environmental

OPER-002: The ROV System must be able to function in fresh, chlorinated water with temperatures between 15°C and 30°C. The water should be considered conductive of electrical currents.

OPER-003: Visibility in the pool is unlimited. The pool will not be covered or purposefully darkened in any way. However, wind, divers, or ROVs may create ripples on the surface that affect visibility. Companies should plan accordingly.

OPER-004: There will be no water currents intentionally created. However, depending on the venue, pressurized pool filtration system outlets may cause unexpected currents.

Note: Contact [your regional coordinator or visit your regional contest's website](#) to learn more about the environmental operating conditions of the competition pool. Some pools may have sloping bottoms or other features that could affect your ROV's performance.

3.1.3 Service Requirements

OPER-005: Companies shall provide a product demonstration team of at least 3 but no more than 4 people to operate the ROV on the pool deck. Companies may have more than 4 people, but only 4 company members are allowed on the pool deck to operate the vehicle.

3.1.4 Maintenance and Calibration Requirement

OPER-006: All work and system maintenance during operations shall be conducted by company personnel. Work of any kind must NOT be done by mentors or advisors.

All measurement devices shall be calibrated according to manufacturer recommended calibration procedures and performed by company members only. Company mentors or advisors are not permitted to perform calibration procedures. More information about mentor restrictions is provided in the [COMPETITION RULES](#).

3.2 Mechanical/Physical

This section of the document provides specifications for the mechanical properties of the ROV system.

3.2.1 Materials

MECH-001N: Any electronics housings on the ROV shall be capable of operating to depths of 4 meters.

3.2.2 Size

MECH-002N: ROVs are not limited to a maximum size, but companies must be able to personally transport the vehicle and associated equipment to the product demonstration station and to the engineering presentation room. ROV systems must be capable of being safely hand launched.

3.2.3 Tether Length

MECH-003N: ROVs must be capable of operating in a maximum pool depth of 4 meters (13 feet). All underwater product demonstrations will take place within 6 meters (20 feet) from the side of the pool. Tether lengths should be calculated accordingly.

Note: Many NAVIGATOR class competitions are held in water less than 4 meters deep. Contact [your regional coordinator or visit your regional contest's website](#) to determine the maximum depth of the SCOUT competition.

3.2.2 Vehicle Deployment and Recovery

MECH-004N: The product demonstration team must be able to carry the entire vehicle by hand. The crew must be able to hand launch and recover the ROV. No lifts or levers may be used to launch the ROV.

3.2.3 Propellers

NOTE for 2025!!!

MECH-005N: All thrusters must be shrouded. ROVs that have propellers exposed without shrouds will not pass the safety inspection and will not be allowed to compete. A shroud must completely encircle the propeller and extend at least 2 mm in front of and behind the propeller. Shrouds must completely cover any openings on the thruster and should have a mesh size that meets [IP-20 standards](#) (solid particulate protection level 2). This IP code equates to a mesh size <12.5 mm. To pass safety inspection, the shroud should meet this standard. If your finger can touch the propeller, then it is not properly shrouded.

Teams may construct shrouds, 3D print shrouds, or may purchase commercially available shrouds. All motors on the ROV must be protected with shrouds on all sides.

An example of a shroud

[MATE Compatible ROV Kort Nozzle for Bilge Pump Thruster](#) – CAD

[MATE Compatible ROV Kort Nozzle for Bilge Pump Thruster](#) – Photo

3.3 Electrical

ELEC-001N: All power provided to your ROV system must be obtained from the MATE competition power supply. This is a singular point of connection; all power to your ROV must pass through the MATE-provided fuse on the supply AND the single fuse in your wiring.

ELEC-002N: MATE will provide a nominal 12VDC power source at the product demonstration station. This power source may be a battery or a power supply. Nominal voltage may be as high as 14.8 volts.

ELEC-003N: Voltage may never be increased above the nominal 12 volts anywhere in the ROV system.

3.3.1 Non-ROV Device Power Specifications

NOTE for 2025!!!

The vertical profiling float with a temperature sensor is considered a non-ROV device. This is a device separate from the ROV that a company can deploy and control to fulfill its mission. The following are rules for the float.

ELEC-NRD-001: The vertical profiling float MUST be powered from the surface; it may not use onboard batteries. **Voltage is limited to 12 VDC maximum; amperage is limited to 5 amps maximum.** All power for the non-ROV device must come from a surface supply, must go down tether wires, and must go through a single fuse (see ELEC-NRD-004).

The temperature sensor on the non-ROV device may be powered independently from the vertical profiling float if the sensor:

- Is purchased “off the shelf” with integrated batteries
- Has a voltage less than or equal to 9v

Provided the off-the-shelf temperature sensor system meets the above requirements, the system does not need to be opened to insert a fuse. **This rule is for the non-ROV device temperature sensor only!** This does not apply to the ROV.

Only electrical wires are allowed to be connected to the float. **You may not use pneumatics or hydraulics on your float.**

ELEC-NRD-002: The vertical profiling float non-ROV device may use thrusters or a buoyancy engine to descend/ascend but no cameras are allowed on the float.

ELEC-NRD-003: Connection to power must be red/black Anderson Powerpole Connectors. The red and black pole pieces must be attached together. Loose Powerpoles (those not attached together) will not pass safety inspection. MATE will provide a 12-volt power source for the float at the mission station.

ELEC-NRD-004: A 5-amp (or less) fuse is required. The fuse must be installed in the positive power supply line within 30 cm of the power supply attachment point.

- ATO type blade fuses or MINI blade fuses MUST be used for any fusing. These fuses provide easy visual inspection for amperage using industry standard color codes. Fuse Reference: [ATO fuse](#) [MINI fuse](#)
These fuses are all rated for 32VDC and are color coded for amperage.
- All blade fuses MUST correspond to the standardized color codes listed on the fuse links above

3.3.2 Current

ELEC-004N: ROVs are limited to 15 amps at 12 volts.

The ROV **MUST** have a 15A maximum (or smaller) fuse in the positive power supply line within 30 cm of the positive Anderson Powerpole connector. The SID must show this fuse, using a proper fuse symbol, and include the amperage rating of the fuse.

NOTE for 2025!!!

Companies MUST use ATO type blade fuses or MINI blade fuses. These fuses provide easy visual inspection for amperage using industry standard color codes.

Fuse Reference: [ATO fuse](#) [MINI fuse](#)

These fuses are all rated for 32VDC and are color coded for amperage. All blade fuses MUST correspond to the standardized color codes listed on the fuse links above.

COMPANIES WITHOUT A PROPER BLADE FUSE WILL NOT PASS SAFETY INSPECTION!

How to select the proper fuse size for your ROV

MATE is modifying its specifications on how fuse size is selected for the ROVs. Past methods allowed currents well beyond the class maximum fuse due to the time delay of the fuses. For 2025, companies must measure the full load amperage (FLA) of the ROV while in water and then select the next standard size fuse that is both above the FLA and equal to or below the class maximum fuse size. To measure the full load amperage, companies should:

- Submerge your ROV in water and apply full down and full forward on all motors (this should be your highest current draw)
- Measure the Full Load Amperage (FLA) with an ammeter
- Select the next higher standard fuse size from the table below

Companies should not itemize individual device currents, only report the actual measurement of the FLA. Do not multiply by 150% as in past years.

12V Full Load Amps	Fuse Size	ATA Fuse Color
< 3.5 A	3 Amp	Violet
3.5 A – 4.5 A	4 Amp	Pink
4.5 A – 5.5 A	5 Amp	Tan
5.5 A – 8 A	7.5 Amp	Brown
8 A – 10.5 A	10 Amp	Red
10.5 A – 15.5 A	15 Amp	Blue

If the ROV FLA exceeds the maximum current, companies should limit their ROV current to prevent blowing the fuse during the competition. An example of this would be limiting the maximum PWM applied to the thrusters.

New for 2025!!!

Full load amps values must be included on any SID and in the Company Safety Review. Full load amps and fuse selection should be reported as follows:

ROV Full Load Amps (FLA) in water = _____

Fuse size selected based upon FLA = _____

SIDs without FLA values or without fuse size selections will have points deducted from their initial safety inspection. Also, SIDs without FLA values will not pass the safety inspection. All FLA values must be measured with the motors in water.

The MATE power supply will be protected by a 30-amp fuse; however, the ROV system must also have its own properly selected fuse.

Note for 2025!!!

The power supplies used by the MATE ROV Competition have integrated circuit protection. Under most conditions, this protection will activate before a company's fuse blows. If a company experiences a power supply circuit protection event during a product demonstration run, it will be assumed that there is an electrical fault within the ROV system. It will be at the discretion of the lead safety inspector or their designate whether the company may continue the product demonstration, and whether the ROV will need to be reinspected by a safety inspector.

Regionals that do not use power supplies, but use 12-volt batteries, should not experience these integrated circuit protection conditions.

NOTE for 2025!!!

ELEC-005N: ROV systems are allowed only one replacement fuse during the product demonstration run. In the event that the ROV system blows the second fuse during the product demonstration, time will stop, the product demonstration run will be over, and no additional points will be earned. Note: Companies must provide their own replacement fuses. MATE will not provide replacement fuses.

Note for 2025!!!

The required ATO or mini fuse **MUST** be within 30 cm of the connection to the MATE 12-volt power supply. There should be no other components between the Anderson powerpole connections that connect to the MATE supply and the fuse.

3.3.3 Power Connections

ELEC-006N: Power supply connections will be red/black Anderson Powerpole Connectors. Companies' ROV system power wires must have proper connectors to obtain power.

NOTE for 2025!!!

The red and black pole pieces must be attached. Loose Powerpoles (those not attached) will not pass safety inspection.

[30 Amp Permanently Bonded Red/Black Anderson Powerpole Connectors | Powerwerx](#)

or

[30 Amp Unassembled Red/Black Anderson Powerpole Connectors | Powerwerx](#)

or

[ASMPP30-1X2-RK Anderson Power Products, Inc. | Connectors, Interconnects | DigiKey](#)

These are two-piece connectors as shown in the picture below.



ELEC-007N: The power supply may be located up to 2 meters from the station and may be located on either side of the station. MATE recommends a power cable long enough to reach the power supply up to 3 meters from your control system.

3.3.4 Tether Voltages

The signals in the tether must meet the following specifications:

ELEC-008N: Low voltage, low current AC or DC control or sensor signals. Low voltage is defined as a voltage equal to or less than the maximum supply voltage per class specification. Low current is defined as being less than 500 mA.

Note: Companies concerned about how voltage loss will affect their camera(s) should consider adding a separate line in the tether to supply the camera from the main power source. This dedicated line for cameras is permitted, provided it runs through the single fuse or circuit breaker.

ELEC-009N: DC main-supply at a nominal voltage of 12VDC as provided by the MATE power supply.

ELEC-010N: Ethernet, USB, or other ANSI or IEC accepted serial protocol signals.

ELEC-011N: NTSC or PAL Video signals

ELEC-012N: Fiber optic cabling of any type may be used.

3.3.5 Exposed Connections and Disposable Motors

ELEC-013N: All electrical components going into the water must be waterproofed. ROVs with electrical connections that are exposed to the water and not sealed will not be permitted to enter the pool. Disposable motors (motors with no waterproofing) are not permitted. Taping a connection with only electrical tape does not constitute a sealed connection. The process of sealing electrical connections must include methodologies such as, but not limited to, silicone RTV, hot melt glue, epoxy, self-vulcanizing tape, and enclosing the connection inside a housing.

ELEC-014N: "Disposable motors" are not permitted; these are exposed motors with no waterproofing.

3.4 Onboard Electrical Power

ELEC-015N: Onboard electrical power (i.e., power not provided by the tether) is not allowed on the primary ROV.

NOTE: Water leaking into a closed battery container can result in the generation of hydrogen gas. This gas can build up inside a pressure housing and create an unsafe situation. Any battery housing must be designed to open if the pressure inside the housing is greater than the outside pressure to meet the MATE safety standards.

3.5 Power Shutdown

ELEC-016N: For safety purposes, any ROV system that is disconnected from the surface supply must stop functioning in less than 5 seconds. This applies to electrical, pneumatic, and hydraulic power sources. Any filters, capacitors or accumulators must be sized accordingly to meet this specification.

3.6 Fluid Power

Any vehicle using fluid power must provide a fluid power diagram. Fluid power is defined as hydraulic pumps (water) or pneumatic pumps (air) on the vehicle or on the surface.

3.6.1 Hydraulic Power

FLUID-001: Hydraulic fluid: Water only.

FLUID-002: Maximum Hydraulic pressure allowed: 10.33 bars (150 psig).

NOTE for 2025!!!

FLUID-003: Hydraulic system: All lines, fittings, and hydraulic devices must be rated for a minimum pressure of two (2) times the maximum supply pressure. Hydraulic component specifications must be included in the Company Safety Review.

FLUID-004: Hydraulic pumps must be part of the safety inspection.

- They must have a pressure relief valve with a maximum setting of 300 psig or less installed before the pressure regulator.
- The pump must have a regulator in place and set to 150 psig or less.
- Pumps with any sign of external rust or deterioration will not be accepted.
- All wiring must be secure.
- All guards must be in place.
- Hydraulic pumps may run off of the 15 A 115 VAC outlet provided for command and control as long as the hydraulic fluid is not used to propel the ROV. The hydraulic fluid is to be used for grippers and actuators only.

Companies using hand/manually powered hydraulic systems do not need a pressure relief valve or regulator in their system. The hand/manually powered hydraulic system must be included on a SID.

3.6.2 Pneumatic Power

FLUID-005: Pneumatic fluid: Compressed air or inert gas only

FLUID-006: Maximum pressure allowed: 2.75 bars (40 psig)

Note for 2025!!!

FLUID-007: Pneumatic system: All lines, fittings, and pneumatic devices must be rated for a minimum pressure of two and a half (2.5) times the maximum supply pressure. For example, if an 83 bar (1200 psig) tank is regulated to 2 bars (30 psig), then all system components must have a minimum rating of 5.17 bars (75 psig). Pneumatic component specifications **MUST** be included in the Company Safety Review. **Note: Aquarium tubing is not generally rated for the pressures associated with compressed gas systems and should not be used in a pressurized pneumatic system.**

FLUID-008: Air compressors must be part of the safety inspection.

1. The company's system must have a pressure regulator, shut-off valve and manual pressure release. See [Compressed air at the MATE ROV Competition](#) for more information.
2. The regulator must be set to 40 psig or less.
3. Compressors with any sign of external rust will not be accepted.
4. The tank drain valve must open.
5. If more than 5 ml of water exits upon opening the drain valve, the compressor will not be accepted.
6. All wiring must be secure.
7. All guards must be in place.
8. Air compressors may run off of the 15A 115VAC outlet provided for command and control as long as the air is not used for motor thrust. The air is to be used for buoyancy/ballast, grippers and actuators only.

3.6.3 Pressurized Cylinders / Unpressurized Containers

New for 2025!!!

FLUID-009: Pressurized cylinders (SCUBA tanks) are not allowed.

Note for 2025!!!

FLUID-010: Electronic housings and other enclosures on the ROV must operate at surface pressures. Companies may not pressurize their electronics housing.

3.6.4 Unpressurized Cylinders

FLUID-011: Companies may fill containers on the ROV with air provided those containers never exceed ambient pressure. Any such container is required to have at least one ¼-inch (6.35 mm) hole drilled into the bottom of the container to allow excess air to escape.

3.6.5 Pressure Storage Devices (Pressure Accumulators)

FLUID-012: Pressure storage devices are allowed on the ROV if they do not exceed 1.25L in total storage and do not store pressure higher than the allowed pressure for air or hydraulics. It is recognized that a company may not be able to purchase a pressure accumulator that has the proper rating and fits in the space needed. In that case, the company must show that

their designed accumulator is capable of withstanding the specified pressures without rupture.

3.6.6 Chemical Creation of Gases

The chemical creation of gases is not allowed.

3.6.7 Fluid Power Quiz

FLUID-013: NAVIGATOR class companies planning to use hydraulics and/or pneumatics (i.e., fluid power) are required to take and pass an online quiz with a score of 100%. Companies ONLY using manual pumps and unpressurized containers are not required to take the Fluid Power Quiz but must still submit documentation regarding their fluid power system.

NOTE: The quiz was developed by MATE ROV Competition technical support staff and competition judges and is designed to ensure that companies understand basic information on these topics and can apply that knowledge to safe practices. The intention is not to add yet another “requirement,” but rather to provide a safe and successful learning experience and competition environment.

The quiz should be completed by the STUDENT company members. Each member of the company does NOT have to take the quiz; students can work together and make it a group effort. **ONLY ONE TEST PER COMPANY.** The company’s instructor or mentor can provide guidance and advice, but the questions should be answered by the students participating on the company. The quiz will be scored, and the results provided instantaneously. A score of 100% is considered a passing grade. Companies can take the quiz as many as 5 times to achieve this score.

The quiz must be completed with a passing grade by April 30th, 2025. NO EXCEPTIONS OR EXTENSIONS! Companies with regional competition prior to April 30th due date should plan to take the fluid power quiz at least 2 weeks prior to their competition. If registration for your regional competition opens after the fluid power closing date, you must still take the quiz before April 30th. Companies failing to complete this quiz within the given time frame will NOT be permitted to use fluid power during their competition event. **NO EXCEPTIONS OR EXTENSIONS! See [6.2 KEY DEADLINES](#).**

To purchase and take the fluid power quiz, click [here](#).

The following are sources of information on hydraulics and pneumatics. This is not intended to be an exhaustive list, but rather a starting point to encourage companies to seek out additional information and resources:

- [Underwater Robotics: Science, Design, and Fabrication \(Revised Edition – SeaMATE](#), published by the MATE Center and MATE Inspiration for Innovation
- [What is Fluid Power? \(nfpa.com\)](#)
- [Full Guide to Air Compressor Safety | Quincy Compressor](#)

3.7 Control Systems

ELEC-017N: NAVIGATOR companies are not limited to the type of control system they may use provided it complies with the other MATE design and safety specifications.

ELEC-018N: Surface control stations must be built in a neat and workmanship-like manner. Loose components and unsecured wires will not pass safety inspection.

ELEC-019N: Surface control stations by nature may combine 120 VAC and 12 VDC wiring. The surface control stations must be wired in a manner such that the 120 VAC wiring is physically separated from the DC wiring, the 120 VAC wiring is clearly identified from the DC and control voltages, and every conductor is insulated in a manner that no conductor is exposed. Identification can be through signage and/or wire color schemes. All 120 VAC wiring colors must use ANSI, NEMA or IEC standard wiring colors appropriate to each voltage. There must be a sign inside the surface control station indicating which wiring standard is being utilized. Companies that do not have adequate separation of AC wires and components and DC wires and components will NOT pass the safety inspection. It is recommended that separation be designed into the control system to keep power systems separate. Wiring should be clear, neat, and easy to follow by inspectors. Wiring “rat’s nests” or “spaghetti wiring” will not pass safety inspection.

ELEC-020N: Companies must use proper strain relief and abrasion protection where wires and the tether enter the vehicle. The ROV should be capable of being lifted by the tether without damaging the tether connection to the ROV. Tape, glue, zip ties, and other quick methods of strain relief are not acceptable. The intent is to see the wires pass through a connector specifically designed to provide strain relief.

Companies must use proper strain relief at the surface where wires and the tether enter the control system. Pulling on the tether should not strain the wires entering the control system.

NOTE for 2025!!!

Additional information on expected and accepted practices for design and wiring of your system, including proper strain relief, can be found in the following MATE ROV Competition Tech Bulletin:

- [MATE ROV Competition Tech Bulletin – MATE Expected Work Practices](#)

3.8 Command, Control, & Communications (C3)

3.8.1 Power Provided

CCC-001: Surface power: MATE will provide one GFI-protected outlet with a nominal 115 Volts AC (60 Hertz) and 15 amps maximum. This outlet is intended to provide power for pumps and other surface support equipment (e.g. video displays & control boxes). This AC power source CANNOT be used to directly or indirectly power the vehicle.

CCC-002: If hydraulic or pneumatic power is used for vehicle thrust, the power for the pump must come from the MATE supplied DC power supply.

CCC-003: In addition to electric pumps, hydraulic, and pneumatic systems can be powered by manual pumps (e.g. bicycle tire pump) or supplied from a pre-pressurized cylinder. Companies that are only using manual pumps must still comply with all hydraulic and pneumatic specifications, including the creation of a fluid power SID.

3.8.2 Cameras

NOTE for 2025!!!

CCC-004: Cameras are required to pilot the ROV. ROV pilots will be penalized for looking into the pool when piloting their ROV.

All cameras, including USB cameras, must be powered by the MATE supply. Powering a USB camera from the MATE supply can be accomplished by using a USB repeater / extender that has a separate power input at the far (ROV) end. The ROV would then provide the power to the device from the MATE supply. USB cameras plugged directly into laptops are not allowed. Be sure to denote camera power on your SID.

3.8.3 Displays

CCC-005: Companies are limited to ONE video display screen. This display screen may be powered by the MATE provided GFI-protected 115-Volt AC (60-cycle) and 15-amp AC power source described in CAM-001.

3.9 MATE Provided Equipment

MATE will not provide monitors at NAVIGATOR product demonstration stations this year. Companies are responsible for providing their own video monitor.

3.9.1 Companies Sharing Equipment

Companies may share the following equipment during the competition event: monitors and joysticks/controllers.

Companies may NOT share the following equipment during the competition event: control systems and payload tools (e.g. grippers, manipulators).

Contact [your regional coordinator or visit your regional contest's website](#) to determine if equipment can be shared at your regional event.

Companies that plan to share equipment must notify their [regional coordinator](#) at least 4 weeks prior to the event so that this can be considered when creating the schedule. MATE will do its best to accommodate companies sharing equipment.

3.10 Laser Safety Rules

LASR-001: **Companies must forward the specifications of their laser to the [Competition Technical Manager](#) three weeks prior to the start date of their regional competition or by **April 30th, 2025, whichever date is earlier.** Specifications **MUST** include a link to the laser being used. The link should include a photo of the laser and the laser specifications. A**

notification will be sent to the company when the laser is approved. Companies must also bring a copy of their laser specifications to their safety checks. If the laser is being used at a regional event or pool practice, notification will also be sent to the regional competition coordinator.

LASR-002: All lasers must operate in the visible range at either the 630-680 nm (red) or near the 532 nm (green) wavelength. All lasers must fall into the Class I, Class II, or Class IIIa category. Red lasers must operate at 5mW or less. Green lasers must operate at 1 mW or less.

LASR-003: Companies should include detailed specifications of their laser in their technical documentation as well as have that information ready and available during their safety inspection and engineering presentations.

LASR-004: Lasers must have an on/off switch. This switch must be on the surface controller.

LASR-005: All lasers must be powered by the MATE surface power supply. Batteries, including batteries for powering lasers, are not permitted on the vehicle.

LASR-006: Companies using lasers cannot increase the voltage or the current to increase the power of their lasers. Lasers must use the voltage and current set in their specifications.

LASR-007: When out of the water, the laser should have a shield or enclosed beam stop attachment within 30 cm of the laser. This means that the laser beam should not travel more than 30 cm before reaching the shield. This is a requirement at all times when the laser is out of the water. **NOTE for 2025!!!** The beam stop must be attached to the ROV at all times. Companies may not remove the beam stop by hand when the ROV enters the pool. The beam stop should be designed so it floats or moves out of the way of the beam when the ROV is in the water. The shield must be painted with FLAT BLACK paint.

LASR-008: At no time should the laser be focused or deviate from a collimated beam.

LASR-009: When testing the laser at a workstation, companies must display a sign telling others that a laser is being operated.

LASR-010: Operators working with the laser while the ROV is out of the water should wear appropriate laser safety glasses at all times. This requirement is for all laser types. Search online to find laser safety glasses appropriate for the wavelength being used.

Companies must forward the specifications of their laser safety glasses to the [Competition Technical Manager](#) three weeks prior to the start date of their regional competition or by April 30th, 2025, whichever date is earlier. Specifications MUST include a link to the laser safety glasses being used. The link should include a photo of the laser glasses and the laser glasses specifications. A notification will be sent to the company when the laser safety glasses are approved. Companies must also bring a copy of their laser safety glasses specifications to their safety checks. If more than one brand of glasses are used, a copy of each specification sheet should be provided.

The following lasers are acceptable to use in the MATE ROV Competition, although companies may choose to use alternate lasers. NOTE: **ALL COMPANIES MUST STILL**

FORWARD SPECIFICATIONS TO THE COMPETITION TECHNICAL MANAGER, EVEN IF ONE OF THE FOLLOWING ACCEPTABLE LASERS IS USED.

- [Amazon.com: HiLetgo 10pcs 5V 650nm 5mW Red Dot Laser Head Red Laser Diode Laser Tube with Leads Head Outer Diameter 6mm : Industrial & Scientific](#)
- [Amazon.com: Quluxe 650nm 5mw Laser Head Laser Tube Adjustable Focus 3~5V Red Laser Tube, Laser Head Industrial Laser \(Pack of 3\) : Industrial & Scientific](#)

PART 4: COMPETITION RULES



Teamwork/
Collaboration



Content
Knowledge



Safety



Vehicle Design,
Buoyancy, Propulsion

4.1 GENERAL

- All members of the company and their supporters must follow the safety regulations of the ROV competition, pool facility, and event venue.
- All company members and their supporters are expected to conduct themselves in a professional and responsible manner during the competition. Disrespectful behavior towards the judges, officials, pool staff, audience, or other companies will lead to penalty points or disqualification.
- Sabotaging, stealing, or pilfering equipment of other companies will lead to disqualification. Companies found cheating will also be disqualified.
- The MATE ROV competition is, at its core, designed to be an educational and inspirational event for **STUDENTS**. It is designed to challenge them to apply the physics, math, electronics, and engineering skills they are learning in the classroom to solving practical problems from the marine workplace. (See the [MATE Competition Philosophy](#).)

It is expected that all “adults” (non-students; e.g. teachers, mentors, parents) involved in the competition limit their input to educational and inspirational roles. Actual construction of the ROV (particularly in the complex electrical and software areas) must be completed by the students. Adults should teach and advise students about design, electronics, software, and construction, but not complete the work for the students. Throughout the process adults are encouraged to focus on benefits to the students from the process and not simply winning. If it becomes apparent that adults exercised more than an advisory role, judges reserve the right to deduct points or, in extreme cases, disqualify companies from the competition.

ALL work done on the vehicle must be conducted by company members. This includes any work done at home, at school, or during the MATE ROV competition (World Championship and regional). Teachers, mentors, parents, and non-competing students are not permitted to work on the ROVs. They may provide advisory input, but they may not work on the ROV directly. This includes writing or editing software code. All mechanical, electrical, and software modifications and/or repairs to the ROV must be completed by students.

With learning at its core, the MATE competition encourages students to utilize and build upon their skill sets to find creative solutions to designing and building their ROV. Students gain valuable skills and knowledge when creating a component from “scratch,” which is apparent to judges as they review the technical documentation and engineering presentation. However, as they move through the process of analyzing their designs and identifying building materials, students may decide to either build a component from “scratch” or purchase it from a commercial vendor.*** So, while original solutions are encouraged, the use of commercial components is acceptable, provided 1) that the components adhere to the design and building as well as safety specifications for the particular competition class and 2) more importantly, that the students can provide a reasonable, logical explanation for buying versus building.

The competition scoring rubrics are designed to reflect this; points are awarded based on students’ abilities to explain and justify how all of the components and systems work together as an integrated ROV, regardless of if they purchased them, pulled them from public libraries, or made them themselves.

***Note “commercial vendor” includes the [SeaMATE store](#) and other competition programs that sell educational robotics kits. SeaMATE kits were created to remove barriers to participation for teachers and schools unable to easily 1) find parts and materials and 2) set up accounts with multiple vendors. The kits are part of a larger educational package that includes curriculum materials, videos, and other resources to support and enhance learning. And learning is what students who use SeaMATE (or other) kits will be expected to demonstrate during and through the [ENGINEERING & COMMUNICATION](#) components.

It should be noted that purchasing and competing with complete, pre-assembled, commercial ROVs is not permitted.

4.2 PROCEDURAL

- Companies must compete during their assigned time slots. Your company is **NOT** permitted to switch time slots with another company. Failure to show for your scheduled product demonstration or for your company’s engineering presentation will result in “no score” for that particular competition category. **No exceptions.** Assigned time slots will be sent out in advance so that any scheduling concerns can be addressed prior to the event.

- Companies must complete their weight measurements before each product demonstration run. The weight measurements are included as part of the product demonstration score. Companies should be at the weigh in area at least 20 minutes before their scheduled product demonstration run.
- While there is no limit to the number of students who can compete as part of a company, **the product demonstration team (aka demo team) is limited to four students.** The demo team is defined as the team of students who operate the vehicle and its associated equipment during the product demonstration. Only four students will be allowed to enter the product demonstration station, launch, pilot, and perform the tasks. Instructors, mentors, and/or non-student members cannot participate as part of the demo team. **Companies may alternate students on the demo team for the two product demonstration attempts.** (All members of the company should participate in the engineering and communication components; see [ENGINEERING & COMMUNICATION](#) for more information.)
- Only the demo team members and judges are allowed at the product demonstration station during the product demonstration, which includes the set-up and demobilization periods. Other members of the company, instructors, mentors, audience members, and observers (press or special invited guests) must remain outside the product demonstration station or in designated viewing areas.
- Instructors, mentors, parents, and “fans” are **NOT** permitted at the safety inspection stations or repair tables. Two warnings will be issued before individuals not heeding this rule will be asked to leave the venue.
- In addition, instructors, mentors, parents, and fans are **NOT** permitted to work on the ROV. Individuals who are seen working on the ROV who are not student company members will be issued a warning. Two warnings will be issued before individuals not heeding this rule will be asked to leave the venue. If companies choose to take their ROVs off the competition grounds for maintenance and repair, they are expected to observe this rule in the interests of the spirit of the competition.
- To help enforce this, teachers, mentors, parents, and non-competing students MAY have limited access to the workstation areas. Contact the [MATE ROV Competition officials](#) for more information.
- Video devices may be used to record the underwater activities for entertainment and learning purposes **only**. Video will not be used as an instant replay to review judges’ decisions or to challenge product demonstration timing.
- Product demonstration stations will be roped off and marked. Product demonstration stations will contain 2-3 chairs and one 6-foot table long table for companies to use. This table will be within 3 meters of the pool edge. Product demonstration stations will be set up to prevent the pilot(s) from looking at the ROV in or under the water except through the ROV cameras.

- Companies will compete in one product demonstration that will consist of three tasks. Companies will get TWO attempts at the one product demonstration. The higher of the two scores will be added to the engineering and communication score to determine the total, overall score for the competition.
- The product demonstration time consists of a 5-minute set-up period, a 15-minute performance period, and a 5-minute demobilization period. If the demo team and all of their equipment are not out of the product demonstration station at the end of the 5-minute demobilization period, the company will be **penalized 1 point for each additional minute**.

Note: Regional competitions *may not* offer two attempts at the product demonstration. Regional competitions may allow more or less time to complete the product demonstration. [Contact your regional coordinator or visit your regional contest's website](#) for more information.

- Manipulating the tether to free it from underwater obstacles is permitted. Pulling on the tether to speed up the recovery of items or to return your vehicle more quickly to the surface is not permitted and will result in penalty points. Judges will issue one warning if tether pulling occurs. Each future infraction will result in **5** points deducted from the final product demonstration score.
- If your vehicle is completely disabled and/or its tether tangled and unable to free itself from the underwater environment, SCUBA divers can be called in to assist. However, the product demonstration time will NOT stop and **5** points will be deducted from the final product demonstration score.

Diver assistance may not be available at your regional competition. [Contact your regional coordinator or visit your regional contest's website](#) to determine if diver assistance will be available at your regional competition.

- Pilots can only leave the product demonstration station and move poolside to repair, adjust, or alter a vehicle if the ROV is surfaced and at the side of the pool.
- Companies are not permitted to leave debris in the pool. Any debris must be recovered by the ROV before time has expired or the company will be penalized. Debris is defined as pieces of the ROVs, weights, floats, or other items created by the company. Task props are not considered debris unless noted in the Product Demonstration section. The product demonstration notes section may cover special items that can be left in the pool after time has expired.
- No demo team member shall enter the water to complete an object recovery. Only arms and hands are allowed into the pool to retrieve an object or to retrieve the vehicle. Companies will be disqualified or penalized depending on the severity of the infraction.

- Communication between demo team members at the pool edge and demo team members piloting the vehicle will be limited. Only tether management issues (e.g. how much tether is out, how much is remaining on the pool deck) can be discussed. Those team members at the pool edge cannot give any directional or product demonstration task information to the pilot. Judges will issue one warning regarding illegal communication. Each future infraction will result in **5** points deducted from the final product demonstration score.
- Communication using cell phones, text messaging, and online social media tools such as Teams, Zoom, Skype, Facebook, Twitter, instant messaging, etc. is NOT permitted during the product demonstration, either between the demo team members at poolside or between any demo team member and anyone outside of the product demonstration station. The ROV and/or the ROV control system is not allowed to broadcast video or other information to anyone outside of the product demonstration area. No exceptions. Companies found broadcasting any data to those outside of the product demonstration area will be disqualified.
- **Product demonstration judges and other competition officials will only communicate with students.** Judges and officials will NOT communicate with mentors, parents, or other non-student members regarding product demonstration information, challenges, or other issues except during pre- and post-competition briefing sessions.

Companies that wish to issue a challenge during the product demonstration run should immediately communicate this challenge to the product demonstration judges. The judges will discuss and attempt to resolve the issue. If a decision cannot be made, the product demonstration judges will consult with the head judges and competition technical manager to resolve the issue.

NOTE for 2025!!!

- Once a chief judge rules on a challenge, that ruling is final. NO EXCEPTIONS, including appeals to other competition officials. Penalty points may be given if companies continue to pursue the challenge beyond the chief judge's final ruling.

4.3 DESIGN & SAFETY CONSIDERATIONS

- The competition coordinators and host venues stress the importance of safety practices and procedures to all companies. The score sheets and rubrics will reflect the MATE ROV Competition's efforts to encourage and reward companies that demonstrate exceptional safety practices and procedures.
- **ALL ROVS MUST PASS A SAFETY INSPECTION CONDUCTED BY COMPETITION OFFICIALS PRIOR TO ENTERING THE POOL.** These inspections will be conducted topside to ensure that ROV systems meet the design and building specifications and do not pose a risk to the integrity of the event venue. See [VEHICLE DESIGN & BUILDING SPECIFICATIONS](#) for additional information.

- **ROV MOTORS MUST BE WATERPROOFED!** No exceptions. You may use already waterproofed motors (bilge pump motors, etc.) or you may choose to waterproof small electrical motors.

NOTE for 2025!!!

- Propellers must be shrouded. **Companies that have propellers that are not shrouded to IP-20 standards will not pass the safety inspection and will not be allowed to compete.**
- Radio transmitters that operate on a separate battery are permitted. No batteries are permitted to be in or on the water. No exceptions.

Companies should be aware of all the implications of these wireless devices. There is no assurance that an adjacent company's wireless controller will not interfere with your control systems. Adjacent wireless controllers with a battery that has a higher charge than the nearby controller have demonstrated the ability to "hijack" the nearby control signals. In addition, all wireless controllers are susceptible to external sources of electronic interference. Your system may work fine in your home environment, but not in the industrial environment of the competition. MATE will not stop the clock to resolve wireless control issues. Companies deciding to utilize wireless controllers do so at their own risk.

- Keep an eye out for tripping hazards in the product demonstration station and at your company's workstation. Make sure power cords are not laying in pools of water on the deck.
- During your product demonstration, be sure to secure any equipment so that it does not fall off the product demonstration station table, damage the deck, or cause injury.
- Loose fitting clothing, jewelry, and long hair could all become safety issues. Consider securing long shirts or baggy pants, removing jewelry, and tying back long hair when working on or operating your ROV.
- ROVs may be constructed out of materials of your company's choice, provided they meet the design and building specifications and safety regulations. Warning labels should be posted on potentially hazardous components of your ROV system.
- Close-toed shoes are required on the pool deck. Safety glasses are required when working on the vehicle.
- Regional events may require PFDs. [Contact your regional coordinator or visit your regional contest's website](#) to determine if PFDs will be necessary.

PART 5: ENGINEERING & COMMUNICATION



NOTE for 2025!!!

MATE has created an ROV Competition [Marketing Kit](#) that includes logos and guidelines for their use.

The ability to communicate information about your vehicle and the design and building process is equally as important as how well your vehicle performs. Strong communication skills are an essential part of good business practices and one of the most in-demand skills in the constantly evolving, ever-changing workplace.

To emphasize this point, the competition requires the following five engineering and communication components:

- Company spec sheet
- Technical (written) documentation (Examples of spec sheets and technical documentation from previous competitions can be found in the [MATE ROV Competition Archives](#).) Examples of NAVIGATOR technical documentation from previous competitions: [Braeview Academy – Aqua Echo](#) (NAVIGATOR 2014) and [Lochside Academy ROV](#) (NAVIGATOR 2014.)
- Engineering (oral) presentation (Videos of engineering presentations can be found on the MATE Vimeo site: [Jesuit High School](#) (EXPLORER 2019), [404 Engineering](#) (EXPLORER 2021), [Hawks Engineering](#) (RANGER 2021), [Deep Ocean Robotics](#) (RANGER 2021) and [Sea Life Technologies](#) (RANGER 2021.)
- Marketing display (Top marketing displays from the 2024 World Championships): [Hong Kong UST EPOXSEA](#) (EXPLORER 2024), [Miramar College](#) (PIONEER 2024), [St. Francis Catholic High School](#) (RANGER 2024.) Also see [Carrollton Crew](#) (NAVIGATOR 2022) and [Aptos Jr. High School – Circuit Breakers](#) (SCOUT 2023.)
- Corporate Responsibility (OPTIONAL)

NOTE: Regional contests may not require all of the Engineering & Communication components. Contact [your regional coordinator or visit your regional contest's website](#) for more information.

See the [TIPS FOR EFFECTIVE WRITTEN AND ORAL COMMUNICATION](#) for additional information.

NOTE for 2025!!!

Your company should refer directly to the scoring rubrics posted under [Scoring](#) for details on what is required for your company spec sheet, technical documentation, engineering presentation, marketing display, and corporate responsibility. The judges will use the rubrics to evaluate and score these engineering and communication components.

5.1 COMPANY SPEC SHEET

The purpose of the company spec sheet is to provide the judges with a “snapshot” of your company. It includes basic information about your company and vehicle.

Company spec sheets will be reviewed by MATE competition coordinators. Companies will receive up to 20 points for submitting a spec sheet that is **one page** in length, follows the file size and naming specifications, and contains **all** of the following information:

COMPANY SPECS

- **Company and school, club, or community organization name**
- **Home state and/or country**
- **Distance required to travel to the World Championship**
- **History of MATE ROV competition participation.** Be sure to specify if your company and/or the members of your company are “new” or “returning.”
- **Company photo and caption indicating members’ names and roles (e.g. CEO, CFO, Design Engineer, Pilot, etc.).** This photo should include all of the members of your company.
- **Range of grade/college levels represented by the members of your company**

ROV SPECS

- **ROV name** if applicable
- **Total cost.** You must include the approximate cost of any donated items.
- **Size and weight measurements**
- **Total student-hours to design and build.** This should include the number of hours that each and every member of the company worked on the vehicle.
- **Safety features**
- **Special features**
- **Photo of the vehicle**

REMINDER!!! If all of the above information is included, the specifications for length, size, and naming conventions are followed carefully, and the document is submitted on time, this is an “easy” 20 points! You can find the company spec sheet scoring rubric posted [here](#).

5.2 TECHNICAL DOCUMENTATION

The purpose of the technical documentation is to challenge you to effectively and efficiently communicate information using clear and concise text along with graphics, illustrations, and data that add to and complement (and not distract from) the information. Your company must organize and present the information in a way that is logical and complete. The

document should focus on the technical and safety aspects of your ROV/ROV systems, the design rationale behind your engineering decisions, and a critical analysis of testing and troubleshooting done on the vehicle. You should consider this document a reference for both judges and future team members (part of the company's institutional knowledge).

Your company's technical documentation will be reviewed and evaluated by a panel of working professionals – individuals who represent science, exploration, government, and industry. (Don't assume that these same individuals will evaluate your company's engineering presentation!)

Each judge on the panel will award a score (50 points max). Judges' scores and comments will be returned to you shortly after the event.

NOTE: The judges will not review and rescore revised versions of your technical documentation during the competition.

Use the technical documentation scoring rubric posted [here](#) as the guideline for the required components for the technical documentation. This rubric will be posted by March 1, 2025. In the meantime, companies may refer to the [previous year's rubrics](#) for a general idea of the categories and points.

5.3 ENGINEERING PRESENTATION

The purpose of the engineering presentation is to challenge you to effectively and efficiently communicate information with words and "props" (i.e., the ROV). Your company must organize and present the information in a way that is logical and covers the development and testing of your ROVs and the formation and development of your team. The presentation should be delivered as a "technical brief," with references to the technical documentation for additional details. The presentation is THE opportunity your company has to 1) communicate directly and in person your critical thinking, creativity, and engineering reasoning (including build vs. buy) and 2) demonstrate your individual and collaborative contributions to the creation of the vehicle.

During the competition, your company will have 15 minutes to deliver your presentation to a panel of working professionals – individuals who represent science, exploration, government, and industry. (Don't assume that these same individuals will evaluate your company's technical documentation!) After the presentation, the judges will take up to 15 minutes to ask the members of your company questions about your ROV. The judges will evaluate both your presentation and responses to their questions. Each judge on the panel will award a score (50 points max). Judges' scores and comments will be returned to you shortly after the event.

All student members of your company must be prepared to participate in this presentation and the question and answer (Q&A) period. You are required to have your ROV with you. For larger companies, the main presentation may be done by a subset of the overall company. During the Q&A, all members of the company should be prepared to

answer. However, if one student is better suited to answer a specific question, the others may defer the question to that student to answer. For example, if a judge calls on the pilot to answer a question about the tether, the pilot can respond by informing the judge that the tether manager was the lead on that system and allow the tether manager to answer without penalty or loss of points.

NOTE: The engineering presentation is designed to be a face-to-face interaction where students and representatives from industry become engaged in conversation. MATE will not provide audio visual aids, such as slide projectors, computer projection screens, white boards, etc.; however, you are welcome to distribute handouts to help judges better understand the information that you are presenting. Electronic forms of presentation (e.g. PowerPoint or Keynote slides) **are NOT permitted.**

Instructors, mentors, family members, friends, and members of other companies are permitted to attend. However, we ask that those in attendance be respectful and courteous throughout the presentation and follow-up question and answer period. Be mindful that this presentation may be a stressful time for the students. If the room becomes crowded or the spectators become distracting, it is up to the judges' discretion to request that some or all spectators leave the presentation. **While they are permitted to attend, instructors and mentors are not allowed to participate.**

Use the engineering presentation scoring rubric posted [here](#) as the guideline for the required components for the engineering presentation. This rubric will be posted by March 1, 2025. In the meantime, companies may refer to the [previous year's rubrics](#) for a general idea of the categories and points. Judges may ask questions regarding any of these topics not covered in the presentation as well as other questions about the vehicle, the mission theme, or the company.

Preparing for your engineering presentation and Q&A

- Make sure that every member of your company has a good, general working knowledge of your vehicle, even though they may have specialized in one specific aspect of its design and construction.
- Make sure that all the members of your company are familiar with your technical documentation. Ask every member to read it over to catch any errors or omissions. This exercise will help to familiarize everyone with all aspects of the project.
- Generally, you will have more to say about your ROV than can be presented in 15 minutes. That is why it is critical to organize your material and practice communicating it. However, avoid coming across as having memorized your presentation verbatim. Judges want to see that you are prepared and understand the information, not that you can simply regurgitate a rehearsed speech from memory. Ask your instructors or mentors to give you feedback.

Other important items

- If during the engineering presentation it becomes apparent that instructors, mentors, and other adults associated with your company exercised more than an advisory role, judges reserve the right to deduct points or, in extreme cases, disqualify companies.

5.4 MARKETING DISPLAY

The purpose of the marketing display is to challenge you to present technical information in a way that appeals to and is understood by a non-technical audience. It is the promotional piece – you must not only present information about your ROV and your company, but you must also use graphics and design to publicize and “sell” (convince viewers, including the general public, of their value and excellence) your products and people.

During the competition, your company’s display will be evaluated and scored by a completely different group of working professionals – individuals who will represent science, business, government, industry, and education/outreach.

While some judges will have a technical background, others will have a communications, marketing, or public relations background. In addition, there will be visitors to the competition who may not completely understand what an ROV is or how it is used. Think of these visitors as potential future clients who may authorize funding for your work but have a limited understanding of the technology (i.e., you need to explain your technology, the tasks at hand, and “sell” them on YOUR products and services). Design your display to communicate to this type of audience.

Each judge will award a score (50 points max). Judges’ scores and comments will be returned to you shortly after the event.

Each company will have a space approximately 3-feet x 3-feet for its display. Depending on your regional, tables may or may not be provided. Contact [your regional coordinator or visit your regional contest’s website](#) for more information.

Use the marketing display scoring rubric posted [here](#) as the guideline for the required components for the marketing display. This rubric will be posted by March 1, 2025. In the meantime, companies may refer to the [previous year’s rubrics](#) for a general idea of the categories and points.

Creating an effective marketing display:

- Address the overall theme and make real-world connections (how could your company and ROV solve these real-world problems?).
- Address the UN Sustainable Development Goals and ESG.
- Reflect your company’s personality and mindset.
- Make key points and be concise.
- Keep the general public in mind.
- Make sure to label any and all figures, graphs, diagrams, and photographs and credit the source.
- Maximize the use of the 36” by 48” display space.
- Make sure that it is both informational and aesthetically pleasing.

Note: “Accessories” such as video footage, PowerPoint slide presentations running on laptop computers, video projections, etc. are permitted but should be used with discretion. Remember that the judges will have a limited amount of time to evaluate your marketing display and may find excessive use of audio or video presentations distracting.

However, if you do make a video of your ROV building or competition experience, please submit information about it to the [MATE ROV Competition officials](#) so that it can be shared via MATE’s YouTube and Vimeo channels.

5.5 CORPORATE RESPONSIBILITY

The MATE ROV Competition uses underwater robotics to inspire and encourage students’ interest in STEM (science, technology, engineering, and math) education and careers. Recognizing that the students who participate in MATE competitions are powerful ambassadors for the program as well as effective leaders in raising awareness of important issues and bringing about positive change, companies have the opportunity to earn up to 20 points for “corporate responsibility.”

Corporate responsibility includes, but is not limited to, the following:

- **Education focused initiatives** consists of, for example, providing guidance to other students in your area who are designing and building an ROV for the competition or a science or other project.

This follows the industry trends of engaging in educational partnerships and STEM outreach to students. Specific examples of education-focused initiatives include:

- o Mentor newer/less experienced MATE ROV Competition teams
- o Support local schools/organizations
- o One-time / short-term educational activities
 - MATE regional competition volunteer
 - Science fair judging
- o Structured presentations or exhibits that specifically showcase marine technology
 - Career day presentation/talk

Education-focused initiatives will be scored on the number of events, with continual interactions preferred over one-time events, and the reporting of measurable impacts on the participants of the initiatives. Measurable impacts include how many students were mentored, whether mentored students participated at a regional competition or other event, etc.

- **Engaging the community** includes demonstrating your ROV and sharing information about your company at festivities and other community-wide events. Presenting to a Rotary Club or your school district’s board of directors are examples.

This follows the industry trends of participating in STEM outreach to the community and media engagement. Specific examples of engaging the community include:

- o One time / short-term outreach activities such as a STEM activity booth at community events
- o Media engagement

- Press release distribution
- Media coverage secured

Engaging the community will be scored on the number of events participated and the reporting of measurable impacts. Measurable impacts include how many people visited a booth or the amount of media coverage that resulted.

- **Environmental Impact** consists of conducting environmental monitoring and organizing or participating in environmental cleanup activities.

This follows the industry trends of focusing on environmental monitoring and ocean conservation. Specific examples of environmental impact outreach include:

- Scientific data collection and monitoring projects
 - Water quality monitoring
 - Marine habitat assessment
- Organize/participate in beach, waterway or environmental cleanups

Environmental impact outreach will be scored on the number of events. Scientific data collection projects will emphasize an ongoing long-term data collection project with regular data collection and proper calibration of instruments. Public sharing of data will be emphasized as well. Environmental cleanup events will be scored on the number of events, with an emphasis on teams organizing over participating in an event. Additional emphasis will be placed on properly disposing of waste and of proper safety protocols being followed.

- **Knowledge sharing** consists of providing open-source data on your vehicles code and design specifications and engaging social media to follow your company's journey to the competition.

This follows the industry trends of emphasizing open access to data and technology. Specific examples of knowledge sharing include:

- Publishing document code on GitHub/GitLab/other public source
- Technical resource creation, including tutorial videos and technical blog posts
- Maintaining an active project website/blog
- Social media engagement and video documentation
 - Regular updates on company progress
 - Educational content sharing
 - Industry/STEM news sharing
 - Project development videos

Knowledge sharing will be scored on the number of activities, with emphasis on open-source documentation links, and activities being tagged as MATE ROV Competition.

Here are some [general guidelines](#) for working with the media. They are specific to the World Championship but can be easily modified for regional events.

Corporate responsibility efforts will be reviewed by competition coordinators and awarded 0 to 20 bonus points, depending on the number and scope of the outreach and awareness activity(s), i.e., the number of other students or members of the community engaged, the number of mentoring sessions, etc.

Make sure to include the following information in your write up:

- Type of activity (e.g. education-focused activity, engaging the community, environmental impact, knowledge sharing.)
- Locations, dates, and the amount of time spent on the activity.
- Number of students or community members (if a large event, this can be an approximate) involved.
- Description of your actions, outcomes, and other information that helps to demonstrate the quality of your time and efforts. Emphasis will be placed on the impacts and outcomes of the event.
- For media outreach, please submit a copy of your press release, a copy of your media contacts list, and a summary of news articles, TV or radio coverage, etc. that your company received. Include copies of articles and URLs, and list any television or radio coverage. Be sure to include name of outlet, date, and a summary of the coverage.

Use the Corporate Responsibility scoring rubric posted [here](#) as the guideline for your Corporate Responsibility submission. This rubric will be posted by March 1, 2025.

TIPS FOR EFFECTIVE WRITTEN AND ORAL COMMUNICATION

Communicating ideas about how to solve a problem and evaluating those ideas against competing alternatives is a critical skill for anyone entering the workplace. It is a skill that is directly linked to decision making about whether or not to hire (or fund) us and our ability to influence the work that we do.

The key to a successful technical documentation and engineering presentation is the way that critical thinking and engineering reasoning are communicated. You can think of the process as technical “storytelling.”

Technical storytelling includes the use of text, images, schematics, and data to effectively communicate the “story” of how your company brainstormed and evaluated ideas to come up with your solution (e.g. ROV, payload tools, and operational strategies) to the problem at hand (product demonstration tasks). It also involves organizing content to efficiently present your work and justify why you did what you did.

However, you should choose details with care. Each detail should help to answer the question “why is what you did the best solution for your company and for this competition?” Describe why a component in the system is critical and how you chose it. Include specifications or dimensions only if they help to explain the “why” and “how” you made choices. Keep in mind that a mechanical drawing with dimensions can replace a lot of text and in many cases do a better job telling details of the story than text.

That said, if something is hard to describe clearly and completely with two to three sentences, consider whether using an image may help. A good technical document balances text and images to provide lots of information concisely, which for a detailed understanding while being quick and easy to read. Remember that your reader is new to your design and needs to understand both what your design is and the process you used to

get there. Present text and images in a logical order that helps readers follow your development process and results.

Maintaining a project notebook is a good business practice that will help to capture ideas and document your company's progress – including your research, designs, trade studies, experiments, data, vehicle specifications, testing, expenditures, and donations. The notebook is also a place to keep track of your company member's contributions (time, support, etc.).

Along with your notebook, here are some items to consider as you prepare to tell your story:

- What was your company's "work breakdown structure" (tasks, time, and people)?
- What were the greatest constraints (schedule, budget, equipment, labor, logistics, etc.) on your design process?
- How did the product demonstration tasks and rules influence your design and decisions?
- What systematic process, such as a [tradeoff matrix](#), did you use to evaluate competing design solutions?
- What were the most important design decisions you made and why?
- How did you arrive at your final power budget? What concessions, if any, did you have to make and why?
- How do you calibrate your sensors?
- If your vehicle uses software, where does the code execute? Describe the flow and format of the data.
- Did you have a noteworthy troubleshooting experience? Any problem or procedure that takes more than 20 minutes to figure out is worth understanding and writing down.
- How did the mission theme influence your choices across the ROV? What choices would have big impacts had this been in a less controlled environment?

Note for 2025!!!

The Engineering & Communications components are 40% of a company's overall score. Working on these components early and preparing thoroughly (practicing your engineering presentation, proofreading your technical documentation and marketing display) can increase your chances of achieving a higher score.

PART 6: DOCUMENTATION



Communication



Autonomy



Obstacles



Project Management

6.1 DOCUMENTATION

Companies are required to submit a system interconnection diagram (SID) of their vehicle control system. Your regional may also require you to submit technical documentation and a company spec sheet. Corporate Responsibility documents may also (optional) be submitted for your regional competition.

Contact [your regional coordinator or visit your regional contest's website](#) to determine what documentation must be submitted for your regional and the date it is due.

DOC-002: Technical documentation: A technical document or engineering notebook about your vehicle that will be reviewed by a panel of judges. See the [technical documentation](#) section for more information on the contents required for the technical documentation.

DOC-003: Company spec sheet: A one-page document that provides a snapshot of your company and ROV. See the [company spec sheet](#) section for more information on the requirement for the company spec sheet.

DOC-004: SID Electrical: Companies must provide a [system interconnection diagram \(SID\)](#) of their vehicle control system during their safety inspection.

DOC-005: Fluid power SID: Companies using fluid power (hydraulics or pneumatics) must provide a fluid power diagram. The diagram should separate and show what systems are on the surface and what systems are on the vehicle. A fluid power SID for simple syringe hydraulics would consist of a syringe box on the surface connecting to a syringe box on the vehicle.

The fluid power SID can be incorporated into the Electrical SID or can be a separate, one page document.

DOC-006: Documents may be due before the competition or the day of the competition. Regardless, companies MUST bring a SID of their ROV systems in order to pass the safety inspection!

NOTE: By submitting your documentation, you are giving the MATE ROV Competition permission to publish these documents on its web site.

6.2 KEY DEADLINES

Contact [your regional coordinator or visit your contest's website](#) to determine the key deadlines for your regional competition.