

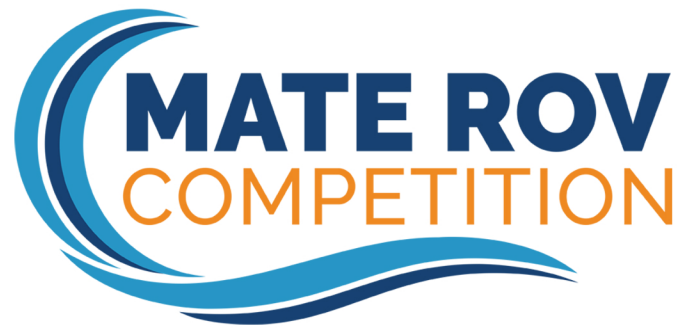

Competition Manual  
Release: 14 September 2020

# 2021

## SCOUT CLASS



MOTOROLA SOLUTIONS  
FOUNDATION

FOUNDATION

Good for Good



Excite, Educate, Empower:  
Students Engineering  
Solutions to Global Problems

## 2021 MATE ROV COMPETITION:

*Excite, Educate, Empower: Students engineering solutions to global problems*

## SCOUT CLASS COMPETITION MANUAL

For general competition information, including a description of the different competition classes, eligibility, and demonstration requirements, visit [Start Competing](#).

### CONTENTS

<b>OVERVIEW</b> .....	<b>3</b>
<b>THINK OF YOURSELVES AS ENTREPRENEURS</b> .....	<b>3</b>
<b>PART 1: PRODUCT DEMONSTRATION</b> .....	<b>3</b>
<b>OVERVIEW</b> .....	<b>3</b>
<b>SCORING OVERVIEW</b> .....	<b>4</b>
<b>TIME</b> .....	<b>4</b>
<b>CONTEXT</b> .....	<b>5</b>
<b>NEED</b> .....	<b>5</b>
<b>REQUEST FOR PROPOSALS (RFP)</b> .....	<b>7</b>
<b>SIZE RESTRICTIONS</b> .....	<b>19</b>
<b>PRODUCT DEMONSTRATION</b> .....	<b>20</b>
TASK 1: THE UBIQUITOUS PROBLEM OF PLASTIC POLLUTION .....	20
TASK 2: THE CATASTROPHIC IMPACT OF CLIMATE CHANGE ON CORAL REEFS .....	23
TASK 3: MAINTAINING HEALTHY WATERWAYS II: DELAWARE RIVER AND BAY .....	25
TIME BONUS:.....	28
PRODUCT DEMONSTRATION RESOURCES .....	29
PRODUCT DEMONSTRATION RESPONSIBILITIES .....	29
<b>PART 2: PRODUCT DEMONSTRATION PROP BUILDING INSTRUCTIONS &amp; PHOTOS</b> .....	<b>29</b>
<b>PART 3: VEHICLE DESIGN &amp; BUILDING SPECIFICATIONS</b> .....	<b>29</b>
<b>1.0 GENERAL</b> .....	<b>29</b>
<b>2.0 SAFETY</b> .....	<b>30</b>
2021 SCOUT CLASS	

2.1 Safety inspection protocol.....	30
2.2 Safety inspection completed .....	32
<b>3.0 SPECIFICATIONS.....</b>	<b>32</b>
3.1. Operational.....	32
3.2. Mechanical/Physical .....	33
3.3. Electrical .....	34
3.4 Onboard Electrical Power.....	35
3.5 Power Shutdown .....	36
3.6 Fluid Power.....	36
3.7 Control Systems.....	36
3.8 Cameras and monitors .....	36
3.9 Lasers.....	37
<b>PART 4: COMPETITION RULES.....</b>	<b>37</b>
<b>4.1 GENERAL .....</b>	<b>37</b>
<b>4.2 PROCEDURAL.....</b>	<b>38</b>
<b>4.3 DESIGN &amp; SAFETY CONSIDERATIONS .....</b>	<b>40</b>
<b>PART 5: ENGINEERING &amp; COMMUNICATION.....</b>	<b>42</b>
<b>5.1 COMPANY SPEC SHEET.....</b>	<b>42</b>
<b>5.2 TECHNICAL DOCUMENTATION .....</b>	<b>43</b>
<b>5.3 ENGINEERING PRESENTATION.....</b>	<b>44</b>
<b>5.4 MARKETING DISPLAY .....</b>	<b>45</b>
<b>5.5 CORPORATE RESPONSIBILITY .....</b>	<b>46</b>
TIPS FOR EFFECTIVE WRITTEN AND ORAL COMMUNICATION.....	47
<b>PART 6: DOCUMENTATION .....</b>	<b>49</b>



This work is licensed under a [Creative Commons Attribution-NonCommercial-NoDerivatives 4.0 International License](https://creativecommons.org/licenses/by-nc-nd/4.0/). Under this license you may download this document. Please give credit to the MATE Center and MATE II. You may not use these materials for commercial purposes without written permission from the MATE Center and MATE II. Please click on the Creative Commons link above for license details.

[www.marinetech.org](http://www.marinetech.org)  
[www.mateii.org](http://www.mateii.org)

## OVERVIEW

### THINK OF YOURSELVES AS ENTREPRENEURS

From the removal of plastic pollution in our oceans to the assessment of the health of coral reefs and maintenance of healthy waterways, individuals who possess entrepreneurial skills are in high demand and stand out in the crowd of potential job candidates. What are entrepreneurial skills? They include the ability to understand the breadth of business operations (e.g., finances, research and development, media outreach), work as an integral part of a team, think critically, and apply technical knowledge and skills in new and innovative ways. Individuals who develop a mindset for innovation and collaboration will be well prepared for the global workplace and ready to tackle today – and tomorrow’s – societal and environmental challenges.

To help you to better understand and develop these skills, the MATE ROV competition challenges you to think of yourself as an entrepreneur. Your first task is to create a company or organization that specializes in solutions to real-world marine technology problems. Use the following questions as a guide.

- What is your company name?
- Who are its leaders – the CEO (chief executive officer – the leader) and CFO (chief financial officer who oversees the budget and spending)?
- Who manages Government and Regulatory Affairs (i.e. who’s in charge of reviewing the competition rules and making sure that they are understood and followed by everyone)?
- Who is responsible for research and development (R&D)?
- Who is responsible for system(s) engineering? Design integration? Testing? Operations?
- Who is responsible for fund-raising, marketing, and media outreach?
- What other positions might you need? (Depending on your personnel resources, more than one person may fill more than one role.)
- What products and services do you provide?
- Who are your potential clients?

In this case, the MATE ROV Competition and the global community are your “clients” who recently released a request for proposals. A request for proposals (RFP) is a document that an organization posts to solicit bids from potential companies for a product or service. The specifics of your product design and rules of operation as well as the specifics of your product demonstration are included below.

## PART 1: PRODUCT DEMONSTRATION

### OVERVIEW

**SCOUT** class companies will take part in ONE product demonstration that consists of three distinct tasks:

**TASK #1: THE UBIQUITOUS PROBLEM OF PLASTIC POLLUTION**

**TASK #2: THE CATASTROPHIC IMPACT OF CLIMATE CHANGE ON CORAL REEFS**

**TASK #3: MAINTAINING HEALTHY WATERWAYS PART II: DELAWARE RIVER AND BAY**

**NOTE:** Regional competitions may not include all 3 tasks of the product demonstration; regional competitions may also give companies more than one attempt at the product demonstration. Contact [your regional coordinator or visit your regional contest's website](#) to determine what will take place at your regional competition. Regardless, the product demonstration score will be added to your [ENGINEERING & COMMUNICATION](#) and [SAFETY](#) scores to determine your total, overall score for the competition.

## SCORING OVERVIEW

The competition consists of product demonstrations, engineering and communication, and safety with the following scoring breakdown:

- **Product Demonstrations**
  - 200 points (max), plus a time bonus
  - Size restriction
    - 10 points (max)
- **Engineering & Communication**
  - Technical documentation – 50 points (max)
  - Engineering presentations – 50 points (max)
  - Marketing displays – 50 points (max)
  - Company Spec Sheet – 20 points (max)
  - Corporate Responsibility – 10 points (max)
- **Safety** – 10 points (max)

**TOTAL POINTS = 400**

**NOTE:** Regional contests may not require all of the Engineering & Communications components or offer the opportunity to earn points for Corporate Responsibility. Contact [your regional coordinator or visit your regional contest's website](#) for more information.

## TIME

The time that your company will have to complete the product demonstration will depend on your regional event. In general, the product demonstration time consists of a 3-minute set-up period, a 10-minute performance period, and a 2-minute demobilization period. Contact [your regional coordinator or visit your regional contest's website](#) to determine how your demonstration will be timed and how long you will have to set up, complete the tasks, demobilize, and exit the station.

At any time during the product demonstration you may pilot your ROV to the surface and remove it from the water for things such as buoyancy adjustments, payload changes, and troubleshooting. However, the product demonstration clock will NOT stop. The only time the clock will stop is if a judge determines that there is an issue that is beyond your control. Otherwise, the clock will only stop after all of the tasks are successfully completed, the ROV has returned to the surface under its own power so that it touches the side of the pool, and a member of your company at the product demonstration station has physically touched the vehicle. Your

ROV is not required to return to the surface between tasks.

## TIME BONUS

Companies will receive a time bonus for each product demonstration run if you:

- 1) successfully complete the tasks,
- 2) return your ROV to the surface under its own power so that it touches the side of the pool, and
- 3) physically touch your vehicle before the product demonstration time ends.

How the time bonus is calculated will depend on your regional event. Your regional coordinator will tell you this when he/she explains how your demos will be set up and how much time you'll have to complete them.

## CONTEXT

“What we have out there is all we have; there is no more.”

- Dame Ellen MacArthur, Founder and Chair of Trustees, Ellen MacArthur Foundation

Each year, the MATE ROV Competition brings together a global community of learners to tackle real-world problems from around the world. This year, the competition is challenging this community to tackle problems that impact the entire world. Plastics clogging our rivers, lakes, waterways, and ocean, from the surface to the bottom of the Mariana Trench. Climate change raising ocean temperatures, affecting the health of coral reefs. Contaminants in our waterways. You can find these scenarios from Pennsylvania to Portugal, Florida to Australia, the Western Pacific to the Mid-Atlantic, and Indianapolis to Indonesia.

## NEED

This year the “client” is us – our global community – and the request for proposals (RFP) is simple: design and build a remotely operated vehicle and the necessary sensors and tooling to tackle the real-world problems of plastics in our ocean, climate change’s impact on coral reefs, and the consequences of poor environmental practices on our inland waterways.

In all of three of these cases, your solutions will focus on remediation, meaning, cleaning up rather than fixing the root of these problems. Addressing the actual cause will take involvement from more than just the MATE ROV Competition community; it will take government agencies, non-governmental organizations (NGOs), corporations, small businesses, research institutions, professional societies, and the general public all working together.

Fortunately, momentum is building.

More and more companies are starting to take environmental, social, and governance (ESG) factors into consideration when making business decisions. ESG factors cover a wide range of topics that are not traditionally part of financial analysis, yet may be important financially when it comes to attracting employees, business partners, and, perhaps most importantly, customers. ESG factors include how corporations respond

to climate change, how good they are with water management, how effective their health and safety policies are in the protection against accidents, how they manage their product supply chains, how they treat their employees, and whether they have a corporate culture that builds trust and encourages innovation.

The term ESG was first used in 2005 in a study entitled “Who Cares Wins.” The study was lead by the United Nations and involved 20 financial institutions from around the world. Its goal was to develop guidelines and recommendations on how to better integrate ESG factors into financial markets and researching and managing investments. At the end of the study, all of the institutions committed to start talking with their stakeholders – investors and corporations – about how to implement the study’s recommendations. They were convinced that the only way to make changes and improvements is to get everyone on board.

Fifteen years later, there has been progress, but there is still a long way to go. The biggest challenge for most corporations is adapting to a new environment that favors smarter, cleaner, and healthier products and services and moving away from the mindset of the industrial era when pollution was tolerated, labor was just another cost (and not real people), and bigger was better (and meant more money). Getting everyone thinking the same way and viewing the world as Dame Ellen MacArthur does is going to take a lot more work. However, what we do here is a start.

Before launch and operations, the ROV must complete a series of “product demonstrations” staged at a swimming pool at various regional locations. (Depth requirements vary depending on competition class; see **SPECIFICATIONS** below.) Companies that successfully complete the product demonstrations and deliver exceptional engineering and communication components (e.g. technical documentation, engineering presentations, and marketing displays) will be awarded the contract.

(Visit [www.youtube.com/watch?v=Tn-jUbpFV4A](http://www.youtube.com/watch?v=Tn-jUbpFV4A) for sound advice from MATE judge Marty Klein. He references 2015, but his words still hold true for each and every competition season!)

## REQUEST FOR PROPOSALS (RFP)

### 1. General

#### *a. The Ubiquitous Problem of Plastic Pollution*



Photo source: [stock.adobe.com](https://stock.adobe.com)

While this image is colorful and artistic, it is also dark and disturbing – especially when you consider that plastics outnumber larval fish in some coastal nurseries. Off the Big Island of Hawaii scientists studying features called “ocean slicks” – ribbons of calm water that form on the ocean’s surface and where larval fish come to feast on prey – found that prey-sized plastics also collect in these fish nurseries, outnumbering the fish 7-to-1 and ending up in the stomachs of many. Little is known about the consequences of larval fish ingesting plastics, but it can’t be good for them. Plastic ingestion by adult fish has been linked to liver problems, tumors, malnutrition, behavioral problems, and death. Without a fully developed liver that can filter toxins, these effects could be even worse in larval fish.

So, add the following image to those of sea turtles with plastics straws stuck in their nostrils or caught in plastic nets. Along with the image, you can add the potentially far-reaching ecological and socioeconomic impacts of plastic build-up in larval fish nurseries to the list of consequences of the ubiquitous problem of plastic pollution in our oceans.





Photo source: [https://i.kinja-img.com/gawker-media/image/upload/s--Vg9gBDua--/c\\_scale,fl\\_progressive,q\\_80,w\\_800/fb9osojkxv5r9qb5l8kv.jpg](https://i.kinja-img.com/gawker-media/image/upload/s--Vg9gBDua--/c_scale,fl_progressive,q_80,w_800/fb9osojkxv5r9qb5l8kv.jpg)

### **Will Who Cares Really Win?**

There is a growing awareness of the harmful impact of plastic pollution, and many parts of the world are taking action to curb it. Realistically, however, it is unlikely that the entire world population will stop using plastic in everyday life; in many cases plastic products have made life easier, more comfortable, and safer. In some parts of the world, access to plastic products is a symbol of economic prosperity.

But there are steps we can and are taking to limit its use (i.e., reusable plastic bags) and find alternatives (i.e., metal straws). Research into “smarter” plastics that breakdown more rapidly into less harmful molecules, or can more easily recycle into other products to eliminate single-use plastics – coupled with the development of technologies that clean-up existing plastics – can allow us to continue to use this material while applying the values of ESG. In the words of David Golden, former Senior Vice President and Chief Legal Officer at Eastman Company, “a sustainable company creates significantly more value in the world than the resources it consumes.”

Yes, who cares really will win.

Take, for example, Pete Ceglinski, CEO of the Seabin Project. An Australian surfer and water enthusiast, Pete was concerned about plastics and other pollution in the ocean. So he and a fellow surfer decided to quit their jobs and do something about it. They became entrepreneurs, researched potential solutions to clearing trash from the water, designed and developed the Seabin, and marketed it to the world.

Pictured below, the Seabin is basically a floating garbage bin. Water is sucked in from the surface by a submersible water pump then passes through a catch bag inside the bin. The catch bag is like a garbage bag liner; it can capture and retain microplastics down to 2 millimeters in size, while a pad at the bottom of the bin filters out oil and other contaminants. Once full, the catch bag can be emptied then replaced within the unit.

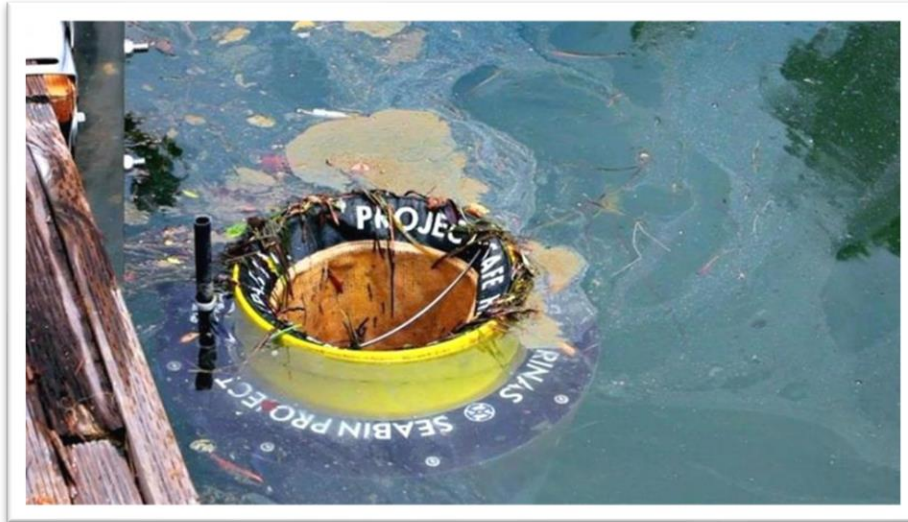

Photo source: <https://www.sail-world.com/news/219741/Fight-against-pollution-with-Ocean-Vacuums>

Since Ceglinski and his partner first started their “socially-driven business model” in 2014, nearly 900 Seabins have been installed in harbors, marinas, and commercial ports around the world. (The first Seabin on the east coast of the United States was installed in a marina in Norfolk, Virginia near Nauticus, the National Maritime Center – the organization that coordinates the MATE Mid-Atlantic Regional ROV Competition!) These are ideal locations because they tend to be in calmer waters, are areas where trash builds up, and provide easily accessible and unlimited power, which allows the Seabin to work 24 hours a day, seven days a week. As a result, to date Seabins have captured a total of 360,000 kilograms of trash.

Ceglinski and his partner are now working on a Seabin for the open water, which would allow them to tackle the gigantic “garbage patches” of plastics that collect in ocean gyres, including the infamous Great Pacific Garbage Patch. How to power those Seabins far from shore is one of the technological and logistics challenges they face, but they are exploring the use of renewable energy sources – wind, solar, and wave.

Another example is businessman and explorer Victor Vescovo, shown in the picture below. In May 2019, Vescovo became only the fourth person in history to travel to the bottom of the deepest part of the world ocean, the Mariana Trench. Working with The [Five Deeps Expedition](#) and its submersible *Limiting Factor*, Vescovo actually set a new record by traveling deeper than the previous three; he “bottomed out” at 10,928 meters. Like oceanographer and inventor Jacques Piccard and U.S Navy Lieutenant Don Walsh in 1960 and movie producer/director James Cameron in 2012, Vescovo looked out his portal when his submersible hit bottom and sent sediment swirling. When the dust settled, he found a “sublime and serene” landscape dotted with translucent fish, a new species of amphipod, and...candy wrappers. As the Washington Post reported, we are going places no one has gone before, but our trash is already there. And in the words of Vescovo, “I was disappointed to see human contamination in the deepest point in the ocean. With over 7 billion people on the Earth, the oceans are going to be impacted negatively by mankind, but I hope we can at least minimize it in the future.”



Photo source: <https://www.lonelyplanet.com/articles/plastic-waste-mariana-trench>

*b. The Catastrophic Impact of Climate Change on Coral Reefs*



Photo source: <https://www.hawaiipublicradio.org/post/corals-are-adapting-higher-temperatures-likely-not-fast-enough#stream/0>

While not nearly as colorful or artistic as the “plastic world” image above, this photo is equally as dark and disturbing. It shows bleached and partially dead coral in Kaneohe Bay on the windward side of the Hawaiian island of Oahu. Scientists running transects of the reef documented the devastation, which results when

environmental stressors like rising water temperatures cause the coral to eject the symbiotic algae that live within their tissues, which in turn causes them to turn completely white. Without their major food source and if the environmental stress continues, the corals will die.

However, in addition to scenes like this, scientists also collected evidence that some species of coral have been adapting to warmer conditions. There are certain species in Kaneohe Bay today that are more resistant to high water temperatures than colonies from the 1970s, all through natural adaptation. While this may be reason to celebrate, adaptation may still not be enough; temperatures are increasing faster than the corals can adapt. Scientists warn that no other changes can substitute for reducing the atmospheric carbon emissions that are causing ocean temperatures to rise each year.

In addition to climate change, corals face natural threats, including predators like the Crown of Thorns sea star. The Crown of Thorns sea star is found throughout the Pacific as well as the Indian Ocean and the Red Sea. Its population is usually kept in check by the Triton's trumpet, a large species of gastropod, the harlequin shrimp, and several species of reef fish that don't appear to be bothered by its poisonous spines. However, outbreaks do occur, fueled by run-off and worsened by warmer water, conditions that also directly stress corals. Corals get a one-two punch and, too often, it is too much for them to survive.

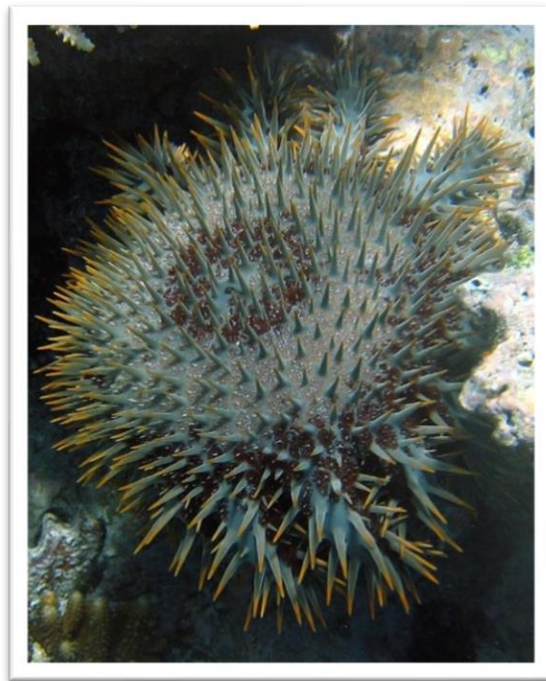

Photo source: [https://en.wikipedia.org/wiki/Crown-of-thorns\\_starfish](https://en.wikipedia.org/wiki/Crown-of-thorns_starfish)

### **Will Who Cares Really Win?**

The catastrophic impact of climate change on coral reefs isn't unique to corals in Hawaii and the western Pacific. There are scenes of bleached and dying corals throughout the Caribbean and the south Pacific.

However, the way that researchers are raising and transplanting coral species to restock and repopulate the reef is. Scientists on Oahu have transplanted corals from the reef to tanks to further study how the different coral species respond to environmental stressors, including increased temperature. The hope is that those corals that demonstrate the ability to adapt to higher temperatures are grown in those tanks then returned to the reef.

In Florida, scientists are using a process called microfragmentation to repopulate reefs. Temperature-resistant corals are sliced into numerous small fragments. These fragments grow extremely quickly, over 10 times faster than normal, and, once they reach a certain size, they are transplanted back onto the reef. When transplanted next to each other, these coral fragments will fuse together into one large colony. Researchers are targeting key reefs to repopulate, including reefs that have special ecological value, are commercially important (i.e., from a fisheries point of view), or are source reefs of larvae that can naturally repopulate other reefs down current.

And in Australia scientists are using “coral nurseries,” both land-based and field-based, like the photo below, to grow coral fragments collected from wild populations. The nurseries are often started with “corals of opportunity;” fragments that have been broken off of the main coral colony by natural disturbances, such as storms, and have little chance of surviving unless stabilized on a nursery structure. Small fragments can also be taken from intact wild “donor” colonies. When the corals have grown to a size large enough to have a good chance of survival, they are then “outplanted” – moved and secured – to the reef.



Photo source: <http://reefresilience.org/restoration/coral-populations/coral-gardening/field-based-nurseries/>

So, yes, who cares really will win.

How scientists in the Western and South Pacific are managing outbreaks of Crown of Thorn sea stars is another example. Both research divers and an ROV called [RangerBOT](#) have been used to cull Crown of Thorn

sea stars when an outbreak occurs. RangerBOT has become especially effective; it uses image recognition to identify the sea stars with a 99.4% accuracy then injects them with ox bile – poisonous to them but not to the other reef organisms.

Another example is Dr. Shirley Pomponi, a researcher at Florida Atlantic University's Harbor Branch Oceanographic Institute, who has spent her career hunting sponges – or, rather, collecting small samples of sponges to search for chemical compounds that could be important in fighting cancers and infections.

In all her years of studying sponges, Dr. Pomponi has never found a tumor in one of them. However, she has found several chemicals that fight infections in humans; a potential cure for cancer may not be far behind. Over the last 40 years, more than 30,000 new chemicals with unique properties that could have medical importance have been discovered in microbes, algae, sponges, bryozoans, and other marine species. The organisms evolved these chemicals naturally and use them to defend against predators, communicate with their neighbors, or prevent algae and other encrusting species from growing on top of them.

So add the medical uses of sponges and other reef organisms to the list of reasons to curb the catastrophic climb of climate change. In the words of Dr. Pomponi, “We want to avoid a situation where the environment is damaged and some unique animal that produces a chemical that could cure cancer or other dreaded diseases is destroyed. If these remarkable sea creatures aren't protected, who knows what we'll lose.”

### *c. Maintaining Healthy Waterways Part II: Delaware River and Bay*

When we left the South Fork of the Holston River in Kingsport, Tennessee last June, we didn't leave the idea that maintaining healthy waterways is important to the survival of benthic organisms and other species, including our own. Coincidentally, one of the research teams that conducted the water quality analysis and habitat surveys of the Holston River is from the Academy of Natural Sciences at Drexel University, which is located in downtown Philadelphia, about 20 miles from Villanova University.

Drexel scientists also monitor waterways closer to home, including the Delaware River. One organism that has gotten their attention is the American eel, pictured below. The American eel is a migratory species that spawns in the Atlantic, but spends most of its life in streams, rivers, estuaries, and lakes. This commercially and ecologically important species was facing a population decline, mainly because of the construction of dams. Notice the word *was*. Dams had drastically limited their migration routes from the ocean to upstream freshwater areas, until scientists – from Drexel University and beyond – stepped in to help the eels on their journey. They built “eel ways,” which are similar to fish ladders but designed to help the eels maneuver over the dams. They also built traps to collect the eels downstream then transport them upstream, above the dam, where the eels were released to continue on their way.



Photo source: <https://usfwsnortheast.files.wordpress.com/2014/06/american-eel.jpg>

### **Will Who Cares Really Win?**

This assistance benefitted more than just the eels – and illustrates the interconnectedness of an ecosystem. Larval mussels need to attach to the gills of fish or other organisms in order to complete their life cycle. Some mussel species rely on American eels to survive. With fewer eels headed upstream, mussel larvae had fewer hosts to help them survive. And, in turn, fewer mussels meant poorer water quality because mussels have the ability to filter liters of water a day. So, saving one species helped to save the entire river ecosystem.

Yes, who cares really will win.

Another example are the scientists and researchers from the Delaware River Basin Commission (DRBC) who monitor the Delaware River and its tributaries as well as Delaware Bay – all pictured below. Their biological monitoring program looks at the diversity of macroinvertebrates throughout the watershed. They also monitor levels of toxic chemicals and heavy metals. In 2010, the Delaware River ranked fifth in the nation for the highest amount of total toxic discharges. Today, because of the efforts of organizations like the DRBC, the clean-up of the Delaware River is celebrated as one of the world's top water quality success stories. The river now supports year-round fish populations, as well as those returning to their “birthplace” to spawn.



Photo source: <https://www.state.nj.us/drbc/basin/>

Another example is the Delaware Reef Program, which is part of an overall fisheries management effort and designed to boost fisheries habitat, benefit structure-oriented fish, and provide fishing opportunities for anglers. Over the long haul, artificial reefs are seen as a salvation for depleted or endangered fisheries.

The program began in 1995 and, to date, has 14 artificial reef sites in Delaware Bay and along the Atlantic Coast, including the Redbird Reef site, which takes its name from the "Redbird" paint-schemed subway cars donated in 2001 by New York City's Metropolitan Transportation Authority. To build the Redbird Reef, 619 of the obsolete subway cars were sunk, each of them 51 feet long by nine wide, making a considerably large bottom structure for an artificial reef.

They went to the bottom just in time, too – Delaware got that bounty of subway cars after other states rejected their use as artificial reef material. Now, with Delaware's success in establishing "luxury condominiums for fish," like the one pictured below, other states are competing for the old cars. For example, New Jersey, which was among the opponents of using them as artificial reefs, now has requested 600 subway cars from New York City.

As the old saying goes, "one person's trash becomes another's treasure." Reduce, reuse, REPURPOSE.



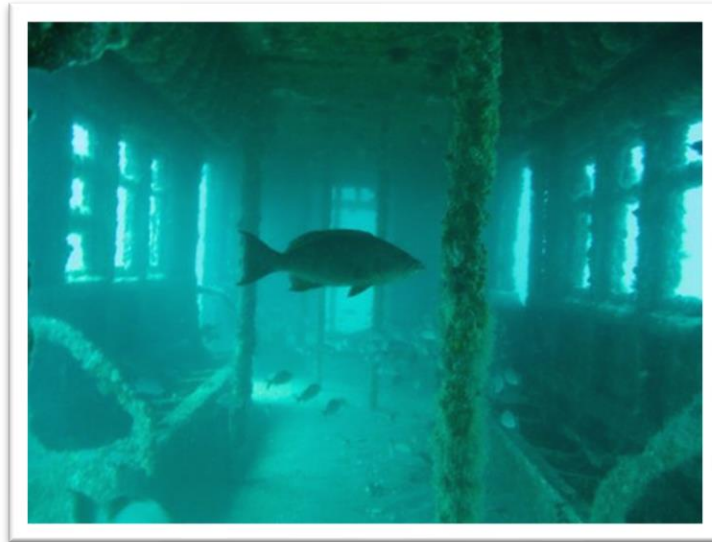

Photo source:

[https://68.media.tumblr.com/bf053d69113a2d11d62532af312ef53d/tumblr\\_nxdh1sRpP01u2hca8o1\\_500.jpg](https://68.media.tumblr.com/bf053d69113a2d11d62532af312ef53d/tumblr_nxdh1sRpP01u2hca8o1_500.jpg)

**THIS IS WHERE YOUR MISSION BEGINS.**

*d. Mission Scope and Purpose*

This and the following sections contain the technical specifications and requirements for ROV services needed to support Eastman. In 2021, ROV services include:

- 1) THE UBIQUITOUS PROBLEM OF PLASTIC POLLUTION**
  - Disconnect the power to a Seabin
  - Replace an old mesh catch bag on the Seabin with a new one
  - Reconnect the power to a Seabin
  - Remove floating plastic debris from the surface
  - Remove a ghost net from midwater
  - Remove plastic debris from the bottom
  
- 2) THE CATASTROPHIC IMPACT OF CLIMATE CHANGE ON CORAL REEFS**
  - Fly a transect line over a coral reef
  - Remove coral fragments from the nursery structure
  - Outplant coral fragments into the reef
  - Cull an outbreak of Crown of Thorn sea stars
  - Collect samples of sponge species for pharmaceutical research
  
- 3) MAINTAINING HEALTHY WATERWAYS PART II: DELAWARE RIVER AND BAY**
  - Return a sediment sample to the surface

- Determine the type of contaminant present in the sediment sample
- Retrieve a sample of mussels and estimate the number of mussels in a mussel bed
- Estimate the total amount of water filtered by the mussel bed
- Remove a trap full of eels
- Place an empty eel trap in the designated area

## 2. Specifications

See the specific tasks described below as well as the [VEHICLE DESIGN & BUILDING SPECIFICATIONS](#) and [COMPETITION RULES](#) sections.

## 3. Maintenance and Technical Support

The company will guarantee the ROV for the duration of the product demonstrations. Repair or replacement will be at the company's expense. The company will provide at least one day of technical support to deal with any issues.

## 4. Shipping and Storage

Delivery of the ROV will be no later than the date of the nearest regional contest.

## 5. Evaluation Criteria

- Technical documentation
- Product presentation
- Marketing display
- Company spec sheet
- Product demonstration
- Safety

## 6. References

### a. GENERAL

- <https://www.forbes.com/sites/georgkell/2018/07/11/the-remarkable-rise-of-esg/#69fbf2881695>
- [https://www.unglobalcompact.org/docs/issues\\_doc/Financial\\_markets/who\\_cares\\_who\\_wins.pdf](https://www.unglobalcompact.org/docs/issues_doc/Financial_markets/who_cares_who_wins.pdf)
- <https://sustainabledevelopment.un.org/?menu=1300>
- <https://www.ellenmacarthurfoundation.org/>
- <http://www.stephense.com/research/papers/oceans08.pdf>

### b. THE UBIQUITOUS PROBLEM OF PLASTIC POLLUTION

- <https://www.nationalgeographic.org/encyclopedia/great-pacific-garbage-patch/>
- <https://www.youtube.com/watch?v=3RLrTCVmLCc>
- <https://theoceancleanup.com/great-pacific-garbage-patch/>
- <https://www.youtube.com/watch?v=ySp7HKD7jaw>
- <https://seabinproject.com/>

- <https://www.weforum.org/agenda/2019/06/underwater-robots-have-found-microplastics-from-the-surface-to-the-seafloor/>
- <https://www.washingtonpost.com/science/2019/05/15/he-went-where-no-human-had-gone-before-our-trash-had-already-beat-him-there/>

*c. THE CATASTROPHIC IMPACT OF CLIMATE CHANGE ON CORAL REEFS*

- <https://allencoralatlas.org/>
- <https://www.aims.gov.au/documents/30301/e4a579c7-6cb9-4484-ac9d-bd4526dd191a>
- <https://www.nrdc.org/stories/scientists-are-battling-mysterious-pathogen-destroying-coral-reefs-floridas-coast>
- <https://newatlas.com/larvalbot-replenish-great-barrier-reef/57666/>
- <http://reefresilience.org/restoration/coral-populations/coral-gardening/field-based-nurseries/>
- [https://en.wikipedia.org/wiki/Crown-of-thorns\\_starfish](https://en.wikipedia.org/wiki/Crown-of-thorns_starfish)
- <https://www.oma.noaa.gov/find/media/images/removal-crown-thorns-sea-stars-during-outbreak>
- <https://www.ncbi.nlm.nih.gov/pmc/articles/PMC4325318/>
- <https://ocean.si.edu/ocean-life/invertebrates/five-questions-shirley-pomponi-medical-sponge-hunter>

*d. MAINTAINING HEALTHY WATERWAYS PART II: DELAWARE RIVER AND BAY*

- <https://ansp.org/research/environmental-research/projects/watershed-protection-program/>
- <https://www.state.nj.us/drbc/basin/>
- <https://www.state.nj.us/drbc/quality/>
- [http://www.buckslocalnews.com/news/environmental-group-delaware-river-tops-list-of-most-polluted-waterways/article\\_b94c90d5-a5c1-5c8e-b39d-2319fa2a511a.html](http://www.buckslocalnews.com/news/environmental-group-delaware-river-tops-list-of-most-polluted-waterways/article_b94c90d5-a5c1-5c8e-b39d-2319fa2a511a.html)
- [https://www.state.nj.us/drbc/library/documents/Yagecic\\_water-quality-monitoring\\_sept2017.pdf](https://www.state.nj.us/drbc/library/documents/Yagecic_water-quality-monitoring_sept2017.pdf)
- <http://www.inphotonics.com/raman.htm>
- <https://usfwsnortheast.wordpress.com/2017/08/21/mussels-making-moves-for-water-quality/>
- <https://usfwsnortheast.wordpress.com/2017/09/08/restoring-rivers-with-a-little-mussel-power/>
- <https://usfwsnortheast.wordpress.com/2014/06/20/bringing-back-american-eels-in-the-susquehanna-river/>
- <http://www.dnrec.delaware.gov/fw/Fisheries/Pages/ArtificialReefProgram.aspx>
- <https://archive.epa.gov/reg3esd1/archive/web/html/reefs.html>

**IMPORTANT NOTE: Questions about production demonstrations and design and building specifications must be posted to the competition FAQs board located at <http://forums.marinetech2.org/index.php>. This allows all companies to see the questions and answers and helps to avoid duplicate questions. That said, please make sure that your question(s) has not already been asked – and answered – before posting. It is up to the companies to read, comprehend, and comply with ALL rulings posted on the FAQ board.**

## SIZE RESTRICTIONS

In light of some of the environments in which the ROVs will be operating, an ROV size and weight requirement has been included in the request for proposals (RFP). Smaller, lighter vehicles will be given special consideration and vehicles above a certain size and weight will not be considered.

All size measurements will include the vehicle, all tools and components, and the tether. The following will NOT be included in the size measurement:

- The topside control system and 1 meter of tether going into the control system

Vehicles will be measured in the on-deck circle 15 to 20 minutes prior to the company's product demonstration runs. Note that the vehicle will be measured before all product demonstration runs. The size bonus, if any, will be added into the product demonstration score.

### 2021 size parameters

Size measurements will be made using the two largest dimensions of the ROV. Two rings with diameters of 48 cm and 60 cm will be located on a table in the on deck circle. Companies will place their vehicles on the measuring table and, when ready, ask a MATE Center judge to make the size measurement. The vehicle measurement must include the vehicle, all manipulators/tools to be used in the product demonstration, and the vehicle's tether. The control system and 1 meter of tether may be outside of the measurement circle. Companies must present their completely assembled ROV for measurement; companies may NOT detach manipulator arms or other equipment for the measurement.

The size rings will be placed over the two largest dimensions of the ROV.

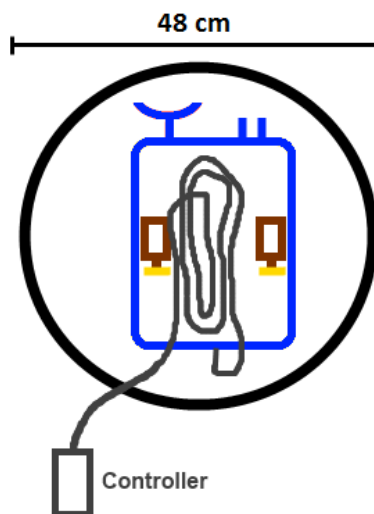

*A SCOUT class vehicle, with tools attached and tether coiled on top, inside the 48 cm diameter ring. This vehicle would earn the company +10 bonus points on the product demonstration score.*

Competition officials will use the following chart to award points:

Size	
< 48 cm diameter	+10 points
48.1 cm to 60 cm	+5 points

Vehicles above 60 cm in diameter will still be allowed to compete, but will receive 0 points for size.

### Size Protocol

Only the four designated product demonstration company members will be allowed into the on-deck circle during and after the size measurement. Once a company's vehicle has been measured, it must remain there until the company moves to its product demonstration station. Companies that detach equipment from the vehicle may not re-install that equipment until the set up period. At that time, companies may replace any items that were detached for the measurement, but no new equipment (i.e., equipment that was not included in the size and weight measurements) may be added to the vehicle. If it is discovered that a company added equipment that was not included in the measurements, that company will not be permitted to compete in that product demonstration run.

Videos showing simulated size and weight measurements are posted [here](#).

## PRODUCT DEMONSTRATION

### TASK 1: THE UBIQUITOUS PROBLEM OF PLASTIC POLLUTION

This task involves the following steps:

#### 1.1 Seabin – “Cleaning up our ocean one marina at a time”

- Disconnecting the old power connector to the recently installed Seabin – 10 points
- Removing a previously installed Seabin's mesh catch bag – 10 points
- Installing a new mesh catch bag into the Seabin – 10 points
- Reconnecting the power connector to the recently installed Seabin – 10 points

#### 1.2 Remediation: Removing plastic pollution from top to bottom

- Removing floating plastic debris from the surface – 5 points each, 10 points total
- Removing a ghost net from midwater
  - Pulling a pin to simulate cutting the ghost net free – 10 points
  - Return the pin to the surface – 5 points
  - Removing the ghost net from the water – 5 points
- Removing plastic debris from the bottom of the Mariana Trench – 5 points each, 10 points total

**Total points = 80 points**

## **Product Demonstration Notes:**

Companies must do the steps of the Seabin – “Cleaning up our ocean one marina at a time” task in order. Companies may not skip any steps of the Seabin task. Companies may complete the steps of Remediation: Removing plastic pollution from top to bottom in any order.

### **Task 1.1 Seabin – “Cleaning up our ocean one marina at a time”**

Companies must conduct maintenance on a Seabin recently deployed in open water. The body of the Seabin will be constructed from a 5-gallon bucket. A ½-inch PVC framework will be secured inside the bucket approximately 5 cm from the top. The mesh catch bag will be simulated by [mesh netting](#) attached to a framework of ½-inch PVC pipe. The framework of the catch bag will sit on the ½-inch PVC framework secured inside the bucket. The power port for powering the Seabin will be constructed from 3-inch ABS pipe attached to ½-inch PVC framework. The power port will be located adjacent to the Seabin. Both the Seabin and the port will be weighted and sitting on the bottom of the pool.

Companies must first disconnect the power connector from the port on the Seabin. The connector will be constructed from ½-inch PVC pipe. A handle will act as a grab point on the connector. A length of rope will run from the connector to the surface. Companies will receive 10 points for successfully disconnecting the power connector from the port. Successfully disconnecting the old power connector is defined as the power connector under control of the ROV, and no longer in contact with the power port or the Seabin. Companies cannot pull the power connector from the port by hand.

Companies that cannot remove the power connector cannot continue with the Seabin task.

The old power connector will weigh less than 5 Newtons in water.

Once the power to the Seabin has been disconnected, companies must remove the old mesh catch bag and install a new one. Both the old and new mesh catch bag will be identical in construction, but the old mesh catch bag will contain plastic debris. The mesh catch bags will be constructed of mesh netting attached to a framework of ½-inch PVC pipe. The PVC pipe framework of the mesh catch bag will rest inside the top of and on the PVC framework inside the Seabin. A PVC handle will act as a grab point for the mesh. The PVC handle will extend above the top opening of the 5-gallon bucket.

Companies must first remove the old mesh catch bag from the inside the Seabin. Companies will receive 10 points when the old mesh catch bag is successfully removed. Successful removal of the old mesh catch bag is defined as the old bag removed from the water and placed on the pool deck.

Once the old mesh catch bag has been removed from the Seabin, companies must install the new mesh catch bag. The new mesh catch bag will be located at the surface, side of the pool during the product demonstration set up time. Companies will receive 10 points for successfully installing the new mesh catch bag. Successfully installing the new mesh catch bag is defined as the mesh catch bag no longer in contact with the ROV, and the

½-inch PVC framework of the mesh catch bag completely inside and resting on the PVC framework secured inside the Seabin.

Note that companies must remove the old mesh catch bag from the Seabin before installing the new one, but companies do not have to return the old mesh catch bag to the surface before installing the new one. For example, companies could remove the old mesh catch bag and hold it in a gripper or set it on the bottom. Companies could then install the new mesh catch bag. Then companies could return the old mesh catch bag to the surface, side of the pool.

Mesh catch bags will weigh less than 5 Newtons in water.

Once the new mesh catch bag has been installed, power must be restored to the Seabin. If the new mesh catch bag has not been installed, companies may not attempt to reconnect the power connector. Companies must reconnect the power by inserting the connector back into the power port. Companies that dropped the power connector to the bottom of the pool after disconnecting power may attempt to pick it up using the ROV or may use the rope to pull it to the surface by hand and reattach it to the ROV. Companies will receive 10 points for successfully installing their power connector into the power port. Successfully installing the power connector is defined as the power connector no longer in contact with the ROV and sitting within the 3-inch pipe of the power port.

### **Task 1.2 Remediation: Removing plastic pollution from top to bottom**

Companies must remove floating plastic debris from the surface of the pool. Two ping-pong balls will be floating on the surface, contained within a 50 cm square ½-inch PVC framework. The framework will be attached to the side of the pool by a length of ½-inch PVC pipe to keep it from drifting. Companies must remove the ping-pong balls (plastic debris) from the surface and return them to the side of the pool. Companies will receive 5 points for each ping-pong ball successfully removed from the water, 10 points total. Successfully removing the plastics debris from the water is defined as the ping-pong balls being removed from the framework under control of the ROV and placed on the pool deck.

Each ping-pong ball will have less than 5 Newtons of buoyant force in water.

Companies must remove a ghost net from midwater. The net will be constructed from ½-inch PVC pipe and [decorative cloth netting](#) attached to the pipe with cable ties. The net will be located midwater in the pool. The net will be positively buoyant. It will be attached to a length of ¾-inch PVC pipe that is secured to a weight on the bottom. Companies must pull a pin to simulate cutting the rope and releasing the net from the weight. The pin will be constructed of ½-inch PVC pipe. Companies will receive 10 points when they successfully pull the pin. Successfully pulling the pin is defined as the pin no longer in contact with the PVC pipe or netting of the ghost net.

After pulling the pin, companies must return it to the surface. Companies will receive 5 points when they successfully return the pin to the surface. Successfully returning the pin to the surface is defined as the pin completely out of the water and placed on the pool deck.

Companies must also return the ghost net to the surface, side of the pool. Companies will receive 5 points when they successfully remove the ghost net from the water. Successfully removing the ghost net is defined as the PVC pipe and netting completely out of the water and placed on the pool deck. The weight and PVC pipe securing the net to the bottom do not need to be removed from the pool.

The ghost net will have less than 5 Newtons of buoyant force in water.

Companies must remove plastic debris from the bottom. The plastic debris on the bottom will consist of two 1-gallon plastic Ziploc bags. ½-inch PVC pipe inside the bag will provide weight to keep the bag from drifting. The PVC pipe will be secured to the inside of the Ziploc bag with industrial strength Velcro. A 50 cm length of rope will act as a grab point on each Ziploc bag. The Ziploc bag will be open at the top, allowing it to fill with water; it will not contain air bubbles. Companies must remove this plastic debris from the bottom and return it to the side of the pool. Companies will receive 5 points for each bag successfully removed from the water, 10 points total. Successfully removing the debris from the water is defined as placing it on the pool deck.

The Ziploc bag and PVC will weigh less than 5 Newtons in water.

## **TASK 2: THE CATASTROPHIC IMPACT OF CLIMATE CHANGE ON CORAL REEFS**

**This task involves the following steps:**

**2.1 Flying a transect line over a coral reef– 15 points**

**2.2 Propagating corals onto the reef**

- **Removing coral fragments from the nursery structure – 5 points each, 10 points total**
- **Outplanting coral fragments to designated locations on the reef – 5 points each, 10 points total**

**2.3 Culling an outbreak of Crown of Thorn sea stars – 5 points each, 10 points total**

**2.4 Collecting samples of sponge species for pharmaceutical research – 5 points each, 15 points total**

**Total points = 60 points**

### **Product Demonstration Notes:**

Companies may complete the steps of Task 2: The Catastrophic Impact of Climate Change on Coral Reefs in any order.

#### **Task 2.1 Flying a transect line over a coral reef**

Companies must fly a transect line over a coral reef. The coral reef will be simulated by a ½-inch PVC pipe rectangle 3 meters long by 20 cm wide. Companies must move their vehicle from one end of the transect to the other, keeping their vehicle above the coral reef area at all times. A station judge will position themselves so they can look down the length of the coral reef. If the station judge determines the vehicle is no longer



above the coral reef area, they will inform the company. The company may reposition at one end and start again.

Companies may start at either end of the coral reef. Companies will receive 15 points for successfully flying a transect line over the coral reef. Successfully flying a transect line is defined as moving from one end of the coral reef to the other with the vehicle above the coral reef at all times.

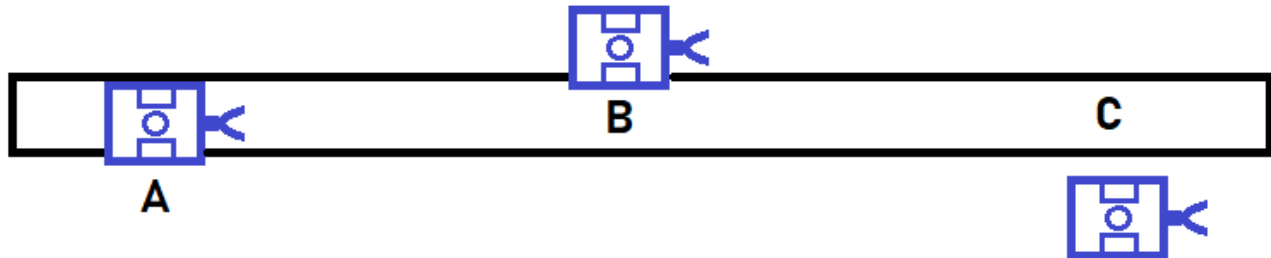

Diagram of an ROV over the coral at three positions. Position A shows the ROV over the center of the coral reef. Position B shows the ROV near one edge, but still successfully over the coral reef. Position C shows the ROV off to one side of the coral reef, failing to successfully fly the transect.

### Task 2.2 Propagating corals onto the reef

Companies must propagate corals onto the reef. Coral fragments will be constructed from ½-inch PVC pipe. A 3/8-inch-16, 3-inch bolt will be attached inside the ½-inch pipe of the coral fragment. A 40 cm length of rope will act as a grab point for each coral fragment. Four coral fragments will be located on a nursery structure. The nursery structure will be constructed from ½-inch PVC pipe. The coral fragments will sit upright on the nursery structure, with the 3/8-inch bolt sitting loosely in an upright section of ½-inch pipe on the nursery structure. Companies must remove two coral fragments from the ½-inch pipe of the nursery structure. Companies will receive 5 points for each coral fragment successfully removed from the structure, 10 points maximum. Successfully removing a coral fragment from the nursery structure is defined as the ½-inch pipe and 3/8-inch bolt under control of the ROV and no longer in contact with the ½-inch pipe of the nursery structure. Companies will not get additional points for removing more than two coral fragments from the nursery structure.

Coral fragments will weigh less than 5 Newtons in water.

Once the coral fragments have been removed from the nursery structure, they must be outplanted onto the coral reef. Two designated areas will be attached to the PVC pipe that simulates the coral reef. Designated areas will be constructed from a 15 cm length of 2-inch pipe and topped with a 3-inch to 2-inch adapter. This pipe will be painted yellow and will rise vertically from the along the side of the coral reef. Companies must insert the coral fragment into the 2-inch PVC pipe.

Companies will receive 5 points for successfully outplanting each coral fragment, 10 points total. Successfully outplanting a coral is defined as the 3/8-inch bolt of the coral fragment positioned inside the vertical 3-inch to 2-inch adapter of the designated area. The coral fragment(s) must remain successfully outplanted into the

designated area for the entire product demonstration run. If the coral fragment is displaced from the designated area at any time during the product demonstration run, the company will not receive points for successfully outplanting the coral fragment. If a coral fragment is displaced from the designated area, companies may attempt to outplant the coral fragment again. Companies may try outplanting the same coral fragment, or may retrieve a different coral fragment from the nursery structure and outplant that fragment.

### **Task 2.3 Culling an outbreak of Crown of Thorn sea stars**

Companies must also cull an outbreak of Crown of Thorn sea stars. Two Crown of Thorn sea stars will be located in the coral reef area. Sea stars will be constructed from ½-inch PVC pipe. Sea stars are culled by injecting them with ox bile. For the purposes of the product demonstration, the ox bile injection will be simulated by a Velcro to Velcro stick. A 5 cm x 5 cm square of Velcro loops will be attached to the center of each sea star. Companies must attach an injection device of Velcro hooks to the Velcro loops on the Crown of Thorn sea stars.

The MATE ROV Competition will provide two injection devices of Velcro hooks at each product demonstration station. These devices provided by the competition will be a 4 cm x 4 cm square of Velcro hooks attached to a ½-inch end cap. The end cap will have a length of rope attached to it as a grab point. However, companies may construct and use their own sea star injection devices of Velcro hooks. Company created Velcro hook must not exceed 6 cm x 6 cm square, should be large enough for the judge to determine that it has been attached to the sea star, and should be black in color. The station judge must be able to see the Velcro hooks attached to the Velcro loops on the sea star. Any additional objects attached to the Velcro hooks should not obscure the judge's view of the Velcro connection.

Companies will receive 5 points when they successfully inject each Crown of Thorn sea star, 10 points total. Successfully injecting the Crown of Thorns sea star is defined as the Velcro hooks on the injection device attached to the Velcro loops on the sea star. The Velcro hooks must remain attached to the sea star for 10 seconds after being released by the ROV. If the hooks fall off the sea star, companies may try again.

Each MATE Competition injection device will weigh less than 5 Newtons in water.

### **Task 2.4 Collecting samples of sponge species for pharmaceutical research**

Companies must also collect samples of sponge species for pharmaceutical research. Sponges will be constructed from ½-inch PVC tees painted red. A rope will act as a grab point for each sponge. Companies must collect three sponge samples and return them to the surface, side of the pool. Companies will receive 5 points for each sample successfully collected, 15 points total. Successfully collecting a sponge sample is defined as the returning the sample to the surface and placing on the pool deck.

## **TASK 3: MAINTAINING HEALTHY WATERWAYS II: DELAWARE RIVER AND BAY**

**This task involves the following steps:**

### **3.1 Retrieving a sediment sample from inside a drain pipe to analyze for contaminants**

- **Returning a sediment samples to the surface –10 points**
- **Determining the two types of contaminants present in each sediment sample – 5 points each, 10 points total**

### **3.2 Estimating the number of mussels in a mussel bed**

- **Retrieve and count a sample of mussels – 10 points**
- **Estimating the number of mussels in the bed – 5 points**
- **Estimating the total amount of water filtered by the mussel bed – 5 points**

### **3.3 Eel restoration**

- **Removing a trap full of eels from a designated area – 10 points**
- **Placing an empty eel trap in a designated area – 10 points**

**Total points = 60 points**

#### **Product Demonstration Notes:**

Companies may complete the steps of Task 3: Maintaining Healthy Waterways II: Delaware River and Bay in any order.

#### **Task 3.1 Retrieving a sediment sample from inside a drain pipe to analyze for contaminants**

Companies will be required to retrieve a sediment sample from the bottom and determine the types of contaminants in the sample. The sediment sample will be constructed from 1 ½-inch PVC pipe with end caps on both sides. A length of rope will act as a grab point on the 1 ½-inch pipe. Companies will receive 10 points when they successfully collect the sample. Successful collection is defined as returning the water sample to the surface, side of the pool.

Once the sediment sample is at the surface, companies can retrieve the sediment’s Raman spectrum.\* In this case, the spectrum will be printed on a laminated sheet and rolled up inside the 1 ½-inch pipe of the sediment sample. Companies must compare the sample’s spectrum to a chart of peaks and sub peaks of known chemical contaminants. A copy of the chart will be available at the product demonstration station. Companies must evaluate the spectrum and the chart to determine what type of contaminants are present in the sediment. Companies will receive 5 points for each contaminant successfully identified, 10 points total. Successfully determining the contaminants is defined as showing the station judge which chemical contaminants from the chart match the peaks and sub peaks of the spectrum retrieved in the sediment sample. The spectrum will contain peaks and sub peaks for two chemical contaminants.

\*Note: Raman spectroscopy is commonly used in chemistry to determine the chemical composition of an object or substance. It can identify and quantify molecules and produce a chemical “fingerprint” of that object or substance. The chemical fingerprint, also known as the spectrum, is generated when the scattered Raman photons pass into a detector where they are broken into their respective wavelengths and plotted. For more information about Raman spectroscopy, see the REFERENCE section of the competition manual.

In Raman spectroscopy, diamonds are used as reference peaks in spectra from unknown sources. The spectrum will have a diamond spike for reference purposes. Diamond is not considered a contaminant.

Chemical contaminant	Main Peak (cm <sup>-1</sup> )	Sub Peak(s) (cm <sup>-1</sup> )
Arsenic Sulfide	385	420
Cadmium Sulfide	520 – 540	
Copper Oxide	297	
Diamond	1332	
Lead	1054	
Mercury	547	435
Polyflouroalkyl	1560 to 1580	1325
PCBs	1590	1575

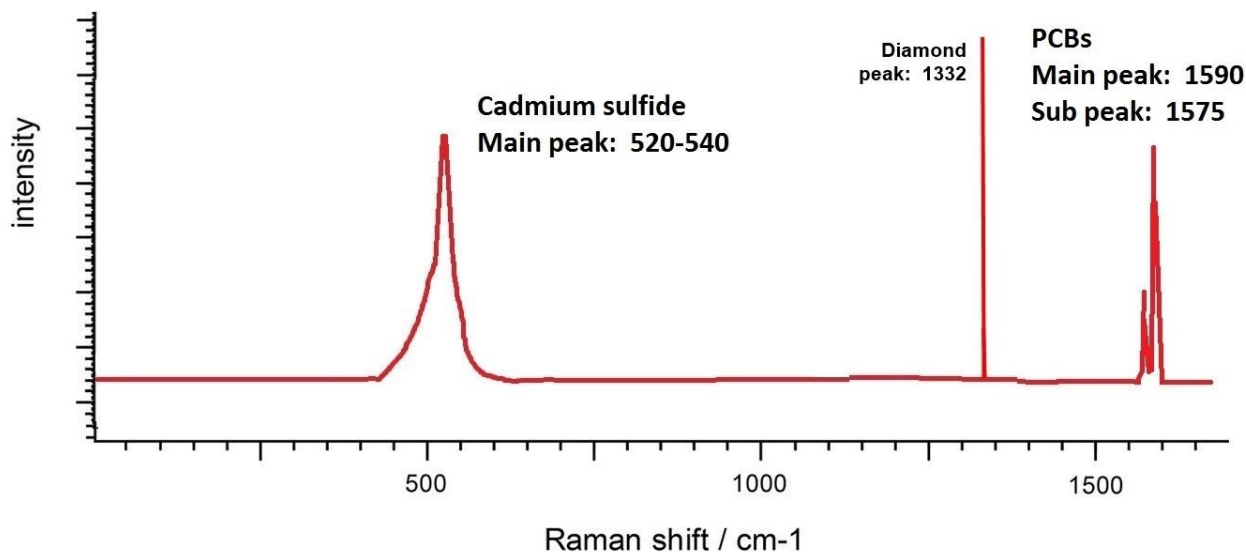

*Raman spectrum of sediment contaminated with CdS (520-540 cm<sup>-1</sup>) and PCBs (1590 and 1575). Note the diamond peak (1332 cm<sup>-1</sup>).*

### Task 3.2 Estimating the number of mussels in a mussel bed

Companies must estimate the number of mussels in a mussel bed. Companies must first retrieve a sample of mussels from the bottom. The sample of mussels will be constructed from a 33 cm square section of corrugated plastic sheeting attached to a ½-inch PVC pipe framework. One side of the corrugated plastic will have a variable number of mussels attached to it. Mussels will be simulated by plastic disks painted tan. A length of rope will act as a grab point. Companies will receive 10 points for returning the mussel sample to the surface and successfully counting the number of mussels on the sample. Companies must report their count to the station judge.

When the company has counted the number of mussels in the sample, the station judge will provide the company with the dimensions of the mussel bed and the average filtration rate of the mussels. Companies should assume the mussel bed is rectangular. The dimensions given will be length and width (in meters) of the bed. Filtration rate of the mussels will be given in liters per hour. Companies must first use the number of mussels counted on their 33.3 cm square sample to calculate the number of mussels per square meter then

use the area of the mussel bed (in meters) to estimate the total number mussels in the bed. Companies will receive 5 points for successfully estimating the number of mussels in the bed. A successful estimation is defined as the total number of mussels within 5 mussels of the actual count. Companies must report their total number to the station judge. If the count is incorrect, companies will not receive points, and the station judge will share the actual count of mussels within the mussel bed.

Companies will then use the total number of mussels in the bed and the given filtration rate to calculate the total amount of water filtered by the mussel bed in liters every hour. Companies will receive 5 points for successfully calculating the total amount of water filtered by the mussel bed. A successful calculation of the total amount of water filtered by the mussel bed is defined as the total amount within 5 liters of the actual amount.

For example, if the overall size of the mussel bed is 43 meters by 8 meters, and the company counted 6 mussels in their 33.3 cm x 33.3 cm sample, the total number of mussels in the bed is 18,576. If the filtration rate of a single mussel is 0.97 liters per hour, the total amount of water filtered by the mussel bed in one hour is 18,018.72 liters.

### **Task 3.3 Eel restoration**

Companies must remove a trap full of eels and replace it with an empty trap to aid in eel restoration. Both eel traps will be identical. The framework for the eel trap will be constructed from ½-inch PVC pipe. Plastic mesh will surround the framework. A #310 U-bolt will act as a grab point for the eel trap. At the start of the product demonstration run, a trap with eels in it will be located in a designated area on the pool bottom. Another, empty trap will be located on the surface, side of the pool.

Eels will be simulated by 1-inch PVC pipe. The designated area will be constructed from ½-inch PVC pipe.

Companies must remove the trap full of eels from the bottom and return it to the surface, side of the pool. Companies will receive 10 points for successfully removing the trap. Successfully removing the trap full of eels is defined as removing the trap from the water and placing it on the pool deck.

Companies must place the empty eel trap in the designated area on the bottom. Companies will receive 10 points for successfully placing the trap in the designated area. Successfully placing the trap is defined as the trap no longer in contact with the ROV, upright, and completely within the designated area. No portion of the trap may be sitting on top of any part of the designated area.

Both the full and the empty eel trap will weigh less than 5 Newtons in water.

### **TIME BONUS:**

If a company has successfully completed all product demonstration tasks and is returning to the surface with the Seabin mesh catch bag, plastic debris, the pin, the ghost net, sponges, or the full eel trap, the product demonstration time will stop when a member of the company touches the vehicle. These items may be

detached and set on the pool deck after the clock has stopped. If any of these items is subsequently dropped from the vehicle and sink to the bottom, the company will not receive points for returning the item to the surface, time will not restart, and the company will not receive a time bonus. Contact [your regional coordinator or visit your regional contest's website](#) for information about how time bonuses will be calculated.

## PRODUCT DEMONSTRATION RESOURCES

The [SCOUT Raman spectrum chart](#) notes the peaks and sub-peaks of various chemical contaminants.

### **NOTE for 2021!!!**

## PRODUCT DEMONSTRATION RESPONSIBILITIES

The MATE ROV Competition will provide sea star injection devices, but companies may design and bring their own versions. Companies must also design and bring any tools or devices to complete the required MATE product demonstration tasks.

The MATE ROV Competition will provide all of the remaining product demonstration items.

Companies are allowed to create a collection basket to collect multiple product demonstration items. Any collection basket MUST be included in size & weight measurements. A collection basket is considered debris if still in the pool and not under control of the ROV when product demonstration time ends.

## PART 2: PRODUCT DEMONSTRATION PROP BUILDING INSTRUCTIONS & PHOTOS

The [product demonstration prop building instructions](#) and photos have been made their own, separate document. This document will be released with, but separate from, this competition manual.

## PART 3: VEHICLE DESIGN & BUILDING SPECIFICATIONS

### 1.0 GENERAL

Questions about vehicle design and building specifications, as well as competition rules, should be posted to Competition Help within the MATE Forum Hub (<http://forums.marinetech2.org/index.php>). That helps to make sure that all companies can view the questions and answers and helps to avoid duplicate questions. That said, companies should make sure that their questions have not already been asked – and answered – before posting. When posting their question, companies should refer to the specific specification (e.g. ELEC-002S).

[Your regional coordinator or your regional contest's website](#) will inform you of any specific requirements or changes for your regional.

## 2.0 SAFETY

Safety is the competition's primary concern and guiding principle. Any system that is considered unsafe by competition officials will not be allowed to compete. If a concern is found during the first safety inspection, companies are permitted to attempt to correct it and have their ROV re-inspected. However, the competition schedule will NOT change to allow companies more time. Companies are allowed to have their vehicle re-inspected twice. If a company fails to pass its third and final safety inspection, it is disqualified from the underwater competition portion of the event. There are NO APPEALS once your ROV has been disqualified.

### Examples of safety violations from previous ROV competitions include:

- The ROV does not use Anderson Powerpole connectors to attach to main power.
- No SID was provided at the safety check.
- The ROV does not have a main fuse.
- The SID did not show a main fuse.
- The ROV used pneumatics, but the technical documentation did not include a pneumatics diagram.
- Sharp items, or potentially sharp items, (fishing hooks, glass bottles, Mercury thermometers) were included on the vehicle.
- The vehicle motors were not waterproofed.
- Propellers were not protected inside the framework or were not shrouded.

### 2.1 Safety inspection protocol

1. Before entering the water for practice or a product demonstration run, the ROV system must go through a safety inspection. Once a company successfully passes inspection, they will turn in their safety inspection sheet to the safety inspector and receive a Blue PASSED Card with their company number on it. Companies must present the Blue PASSED Card to the pool practice/product demonstration coordinator before their vehicles are permitted to enter the water.
2. Competition staff will conduct a safety inspection of the vehicle using the [safety inspection rubric](#).
3. If the safety inspector(s) identify a safety violation, companies will have the opportunity to address it. The pool practice or product demonstration run schedule will NOT change to allow companies more time.
4. If during the second safety review the
  - a. violation has not been properly addressed or
  - b. another violation is revealedcompanies will have ONE additional opportunity to address the issue.
5. If during the third safety review a violation still exists, companies will not be permitted to participate in the underwater product demonstration component of the competition. However, companies can still participate in the engineering and communication (technical documentation, product presentation, and marketing display) component.
6. Reminder: All companies must present the Blue PASSED Card to the pool practice or product demonstration judge before placing their vehicles in the water. In addition, product demonstration station judges and competition officials can pause or stop a product demonstration run at any time if they feel that there is a potential safety concern.

Your regional competition may use a system other than a Blue PASSED Card, but all companies must pass a safety inspection before entering the water. Contact [your regional coordinator or visit your regional contest's website](#) to determine if a Blue PASSED Card or another system will be used for safety verification.

### 2.1.1 System Interconnection Diagram (SID)

To pass the safety inspection, companies must provide a system interconnection diagram (SID) of their vehicle control system. An SID is an electrical diagram of their wiring, including their control box, motors, and any other electrical systems on their vehicle. The SID should separate and show what systems are on the surface and what systems are on the vehicle. The SID must not exceed one page in length. **The diagram MUST show an ROV system fuse. SIDs that do not show a fuse, utilizing an ANSI, NEMA or IEC symbol, with the size of the fuse marked, will not pass their safety check.**

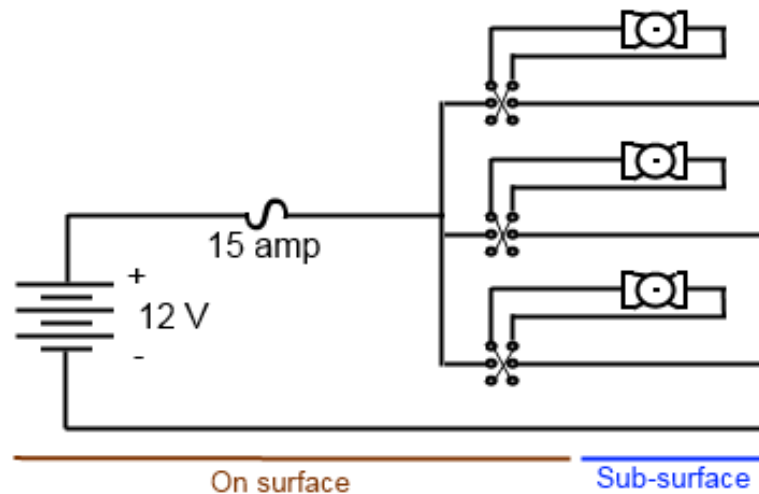



*Diagram: An example of an acceptable SID.*

Companies should create their own SID. Do not simply copy the above SID, or another SID produced by MATE. SIDs help to understand how electricity flows through your system and will provide a better understanding of ROV operations.

DOC-004: Any electrical diagram should use ANSI, NEMA, or IEC symbols as often as possible; it is required for the fuse. They should be neatly hand drawn or created using a CAD software program.



Item	ANSI	IEC
FUSE		

ANSI: American National Standards Institute

IEC: International Electrotechnical Commission

NEMA: National Electrical Manufacturers Association

Note: Companies that do not hand draw their SID may use free drawing software such as MS Paint or [OpenOffice](#) to create their diagrams.

## 2.2 Safety inspection completed

Companies must complete their safety inspection before entering the water for practice or a product demonstration run on the day of the competition.

## 3.0 SPECIFICATIONS

The ROV must meet the following requirements to compete in the event:

### 3.1. Operational

#### 3.1.1 Multiple Vehicles

OPER-001: MULTIPLE VEHICLES ARE NOT PERMITTED. Companies are required to design and build ONE ROV that can complete the necessary product demonstration tasks. All ROV components, including cameras and payload tools, must be connected to the ROV.

#### 3.1.2 Environmental

OPER-002: The ROV System must be able to function in fresh, chlorinated water with temperatures between 15°C and 30°C. The water should be considered conductive of electrical currents.

OPER-003: Visibility in the pool is unlimited. The pool will not be covered or purposefully darkened in any way. However, wind, divers, or ROVs may create ripples on the surface that affect visibility. Companies should plan accordingly.

OPER-004: There will be no water currents intentionally created. However, depending on the venue, pressurized pool filtration system outlets may cause unexpected currents.

**Note:** Contact [your regional coordinator or visit your regional contest's website](#) to learn more about the environmental operating conditions of the competition pool. Some pools may have sloping bottoms or other features that could affect your ROV's performance.

### **3.1.3 Service Requirement**

OPER-005: Companies shall provide a product demonstration team of at least 3 but no more than 4 people to operate the ROV on the pool deck. Companies may have more than 4 people, but only 4 company members are allowed on the pool deck to operate the vehicle.

### **3.1.4 Maintenance**

OPER-006: All work and system maintenance during operations shall be conducted by company personnel. Work of any kind must NOT be done by mentors or advisors.

## **3.2. Mechanical/Physical**

### **3.2.1 Tether Length**

MECH-001S: ROVs must be capable of operating in a maximum pool depth of 4 meters (13 feet). All underwater product demonstrations will take place within 6 meters (20 feet) from the side of the pool. Tether lengths should be calculated accordingly.

**Note:** Many SCOUT class competitions are held in water less than 4 meters deep. Contact [your regional coordinator or visit your regional contest's website](#) to determine the maximum depth of the SCOUT competition.

### **3.2.2 Vehicle Deployment and Recovery**

MECH-002S: The product demonstration team must be able to carry the entire vehicle by hand. The crew must be able to hand launch and recover the ROV. No lifts or levers may be used to launch the ROV.

### **3.2.3 Propellers**

MECH-003S: Propellers must be enclosed inside the frame of the ROV or shrouded. Companies that have propellers protruding outside of their frame will not pass the safety inspection and will not be allowed to compete.

### 3.3. Electrical

ELEC-001S: All power provided to your ROV system must be obtained from the MATE competition power supply. This is a singular point of connection; all power to your ROV must pass through the MATE-provided fuse on the supply AND the single fuse in your wiring.

ELEC-002S: MATE will provide a nominal 12VDC power source at the product demonstration station. This power source may be a battery or a power supply. Nominal voltage may be as high as 14.8 volts.

ELEC-003S: Voltage may never be increased above the nominal 12 volts anywhere in the ROV system.

#### 3.3.1 Current

ELEC-004S: ROVs are limited to 15 amps.

The ROV **MUST** have a 15A maximum (or smaller) fuse in the positive power supply line within 30 cm of the positive Anderson Powerpole connector. The SID must show this fuse, using a proper fuse symbol, and include the amperage rating of the fuse.

#### **NOTE for 2021!!!**

ELEC-005S: ROV systems are allowed only one replacement fuse during the product demonstration run. In the event that the ROV system blows the second fuse during the product demonstration, time will stop, the product demonstration run will be over, and no additional points will be earned. Note: Companies must provide their own replacement fuses. MATE will not provide replacement fuses.

#### 3.3.2 Power Connections

ELEC-006S: The MATE Center requires that all ROVs use Anderson Powerpole connections (<https://seamate.org/collections/power-related-products/products/seamate-angelfish-pufferfish-power-kit-with-powerpole-connectors>, <https://powerwerx.com/anderson-powerpole-connectors-30amp-bonded>).

Power supply connections at all regional competitions will be red/black Anderson Powerpole Connectors.

Anderson Powerpole connections are two-piece connectors as shown in the picture below.



#### **NOTE for 2021!!!**

The red and black Powerpole pieces must be attached together. Loose Powerpoles (those not attached together) will not pass safety inspection.

## Part specification and part numbers

Anderson Powerpole – red and black connector with 30 amp contacts

Red is connected to power supply positive.

Black is connected to power supply negative.

Since Anderson sells the connectors in 2500 and 200 piece quantities, these connectors are available from distributors.

Powerpole Assembly Instructions

<http://www.powerwerx.com/assembly.asp>

<http://www.wb3w.net/powerpoleinst.htm> (see the section on using the TriCrimp tool)

YouTube video for Assembly

Part 1: [https://www.youtube.com/watch?v=8\\_DPPuQN8R4](https://www.youtube.com/watch?v=8_DPPuQN8R4)

Part 2: <https://www.youtube.com/watch?v=EsSsr2zGFqI>

ELEC-007S: The power supply may be located up to 2 meters from the station and may be located on either side of the station. MATE recommends a power cable long enough to reach the power supply up to 2 meters from your control system.

### 3.3.3 Exposed connections and disposable motors

ELEC-008S: All electrical components going into the water must be waterproofed. ROVs with electrical connections that are exposed to the water and not sealed will not be permitted to enter the pool. Disposable motors (motors with no waterproofing) are not permitted. Taping a connection with only electrical tape does not constitute a sealed connection. The process of sealing electrical connections must include methodologies such as, but not limited to, silicone RTV, hot melt glue, epoxy, self-vulcanizing tape, and enclosing the connection inside a housing.

### 3.4 Onboard Electrical Power

ELEC-009: Onboard electrical power is not allowed. All power for the vehicle must come down the tether. Batteries (9-volt, AAA, AA, etc.) are **NOT** allowed under any circumstances.

**NOTE:** *Water leaking into a closed battery container can result in the generation of hydrogen gas. This gas can build up inside a pressure housing and create an unsafe situation. For this reason, onboard batteries are NOT allowed under any circumstance. Any device that needs power must obtain that power directly from the ROV tether. For devices that operate at a voltage other than the tether voltage, an onboard ROV converter may be included. The converter must be sealed and not exposed to water. This rule includes commercial “watertight” battery containers; no battery of any type is permitted on any competition vehicle.*

### 3.5 Power Shutdown

ELEC-010S: Power shutdown: For safety purposes, any ROV that is disconnected from the surface power supply must stop functioning in less than 5 seconds.

### 3.6 Fluid Power

Any vehicle using fluid power must provide a fluid power diagram. Fluid power is defined as hydraulic pumps (water) or pneumatic pumps (air) on the vehicle or on the surface

FLUID-001S: Electrical pumps of any sort are NOT allowed. Companies may only use manual pumps (hand or foot pumps) to push fluids (including air) down the tether and to their vehicle.

FLUID-002S: Companies may only use WATER as their hydraulic fluid. Companies may only use AIR as their pneumatic fluid.

FLUID-003S: Companies may not use pressure accumulators. Pressure inside any container must never exceed the ambient pool pressure. If air is pumped into a container on the vehicle, that container must be open to the water. Vent holes on the container must be at least ¼-inch (6.35 mm) in diameter.

For example: A company wants to fill a PVC pipe container on the vehicle with air. Companies may only use a manual pump (hand/foot powered bicycle pump) to push air down to the vehicle. The company drills four ¼-inch holes in the bottom of the pipe. As they pump air into the container, it will displace the water out of the holes in the bottom of the pipe. However, the pressure inside the container can never get above the ambient pool pressure; excess air will come out the holes on the bottom of the pipe once all the water has been displaced.

### 3.7 Control Systems

ELEC-011S: Control systems must be built in a neat and workmanship like manner. Loose components and unsecured wires may not pass safety inspection. All wires entering and leaving the control system must have adequate strain relief and wire abrasion protection as the wires pass through the box.

### 3.8 Cameras and monitors

CAM-001: Cameras are not required in the SCOUT class. However, if a company chooses to use cameras on their ROV, they are limited to one video display screen. This monitor must be provided by the company; MATE will not provide a video display monitor for SCOUT companies.

CAM-002: All cameras and the one monitor MUST be powered from the MATE 12 volt supply. Companies may not plug cameras or the monitor into AC wall sockets. Companies may not use their own battery packs or USB to run cameras or monitors. NO EXCEPTIONS.

### 3.9 Lasers

SCOUT class companies may NOT use lasers on their vehicles.

## PART 4: COMPETITION RULES

### 4.1 GENERAL

- All members of the company and their supporters must follow the safety regulations of the ROV competition, pool facility, and event venue.
- All company members and their supporters are expected to conduct themselves in a professional and responsible manner during the competition. Disrespectful behavior towards the judges, officials, pool staff, audience, or other companies will lead to penalty points or disqualification.
- Sabotaging, stealing, or pilfering equipment of other companies will lead to disqualification. Companies found cheating will also be disqualified.
- The MATE ROV competition is, at its core, designed to be an educational and inspirational event for **STUDENTS**. It is designed to challenge them to apply the physics, math, electronics, and engineering skills they are learning in the classroom to solving practical problems from the marine workplace. (See the [MATE Competition Philosophy](#).)

It is expected that all “adults” (non-students; e.g. teachers, mentors, parents) involved in the competition limit their input to educational and inspirational roles. Actual construction of the ROV (particularly in the complex electrical and control box areas) must be completed by the students. Adults should teach and advise students about design, electronics, and construction, but not complete the work for the students. Throughout the process adults are encouraged to focus on benefits to the students from the process and not simply winning. If it becomes apparent that adults exercised more than an advisory role, judges reserve the right to deduct points or, in extreme cases, disqualify companies from the competition.

ALL work done on the vehicle must be conducted by company members. This includes any work done at home, at school, or during the MATE ROV competition. Teachers, mentors, parents, and non-competing students are not permitted to work on the ROVs. They may provide advisory input, but they may not work on the ROV directly. All mechanical and electrical and/or repairs to the ROV must be completed by students.

With learning at its core, the MATE competition encourages students to use and build upon their skill sets to find creative solutions to designing and building their ROV. Students gain valuable skills and knowledge when creating a component from “scratch,” which is apparent to judges as they review the

technical documentation and engineering presentation. However, as they move through the process of analyzing their designs and identifying building materials, students may decide to either build a component from “scratch” or purchase it from a commercial vendor.\*\*\* So, while original, student-built solutions are encouraged, the use of commercial, “store-bought” components is acceptable, provided 1) that the components follow the design and building as well as safety specifications for the particular competition class and 2) more importantly, that the students can provide a reasonable, logical explanation for buying versus building.

The competition scoring rubrics are in line with this thinking; points are awarded based on students’ abilities to explain and justify how all of the components and systems work together as an integrated ROV, regardless if they purchased them or made them themselves.

\*\*\*Note “commercial vendor” includes the SeaMATE store and other competition programs that sell educational robotics kits. SeaMATE kits were created to remove barriers to participation for teachers and schools unable to easily 1) find parts and materials and 2) set up accounts with multiple vendors. The kits are part of a larger educational package offered by the MATE Center that includes curriculum materials, videos, and other resources to support and enhance learning. And learning is what students who use SeaMATE (or other) kits will be expected to demonstrate during and through the [ENGINEERING & COMMUNICATION](#) components.

It should be noted that purchasing and competing with complete, assembled, commercial ROVs is not permitted.

## 4.2 PROCEDURAL

- Companies must compete during their assigned time slots. Your company is **NOT** permitted to switch time slots with another company. Failure to show for your scheduled product demonstration or for your company’s product presentation will result in “no score” for that particular competition category. **No exceptions.** Assigned time slots will be sent out in advance so that any scheduling concerns can be addressed prior to the event. Contact [your regional coordinator](#) at least four weeks before the competition if you know you have a scheduling concern.
- Companies must complete their size measurements before each product demonstration run. The size measurements are included as part of the product demonstration score. Companies should be at the size in area at least 15 to 20 minutes before their scheduled product demonstration run. Regional competitions may not require size measurements or may change the size measurement process. Contact [your regional coordinator or visit your regional contest’s website](#) for more information on the size process and scoring.
- While there is no limit to the number of students who can compete as part of a company, **the product demonstration team (aka demo team) is limited to four students.** The demo team is defined as the team of students who operate the vehicle and its associated equipment during the product

demonstration. The product demonstration is held at a “product demonstration station.” Only four students will be allowed to enter the product demonstration station, launch, pilot, and perform the tasks. Instructors, mentors, and/or non-student members cannot participate as part of the demo team. If a regional offers two product demonstration attempts, **companies may alternate students on the demo team for the two product demonstrations. See below for additional information about the number of attempts.** (All members of the company should participate in the engineering and communication components; see [ENGINEERING & COMMUNICATION](#) for more information.)

- Only the demo team members and judges are allowed at the product demonstration station during the product demonstration, which includes the set-up and demobilization periods. Other members of the company, instructors, mentors, audience members, and observers (press or special invited guests) must remain outside the product demonstration station or in designated viewing areas.
- Instructors, mentors, parents, and “fans” are **NOT** permitted at the safety inspection stations or repair tables. Two warnings will be issued before individuals not following this rule will be asked to leave the venue.
- In addition, instructors, mentors, parents, and fans are **NOT** permitted to work on the ROV. Individuals who are seen working on the ROV who are not student company members will be issued a warning. Two warnings will be issued before individuals not following this rule will be asked to leave the venue. If companies choose to take their ROVs off the competition grounds for maintenance and repair, they are expected to observe this rule in the interests of the spirit of the competition.
- Video devices may be used to record the underwater activities for entertainment and learning purposes **only**. Video will not be used as an instant replay to review judges’ decisions or to challenge product demonstration timing.
- Companies will compete in ONE product demonstration that consists of three distinct tasks. Companies may get up to **TWO** attempts to complete each product demonstrations. If that is the case, the **higher** of the two scores will be added to the engineering and communication score to determine the total, overall score for the competition.

In general, the product demonstration time consists of a 3-minute set-up period, a 10-minute performance period, and a 2-minute demobilization period. If the demo team and all of their equipment are not out of the product demonstration station at the end of the 2-minute demobilization period, the company will be **penalized 1 point for each additional minute.**

**Note:** Regional contests may or may NOT offer companies two attempts at the product demonstration tasks. In addition, the product demonstration time frames for set-up, performance period, and demobilization may be different at your regional contest. Contact [your regional coordinator or visit your regional contest’s website](#) for more information.



- Manipulating the tether to free it from underwater obstacles is permitted. Pulling on the tether to speed up the recovery of items or to return your vehicle more quickly to the surface is not permitted and will result in penalty points. Judges will issue one warning if tether pulling occurs. Each future infraction will result in **5** points deducted from the final product demonstration score.
- If your vehicle is completely disabled and/or its tether tangled and unable to free itself from the underwater environment, SCUBA divers can be called in to assist. However, the product demonstration time will NOT stop and **5** points will be deducted from the final product demonstration score.

Diver assistance may not be available at your regional competition. Contact [your regional coordinator or visit your regional contest's website](#) to determine if diver assistance will be available at your regional competition.

- No demo team member shall enter the water to complete an object recovery. Only arms and hands are allowed into the pool to retrieve an object or to retrieve the vehicle. Companies will be disqualified or penalized depending on the severity of the infraction.
- Communication using cell phones, text messaging, and online social media tools such as Skype, Facebook, Twitter, instant messaging, etc. is NOT permitted during the product demonstration, either between the demo team members at poolside or between any demo team member and anyone outside of the product demonstration station.
- **Product demonstration judges and other competition officials will only communicate with students.** Judges and officials will NOT communicate with mentors, parents, or other non-student members regarding product demonstration information, challenges, or other issues except during pre- and post-competition briefing sessions.

Companies that want to issue a challenge during the product demonstration run should immediately communicate this challenge to the product demonstration judges. The judges will discuss and attempt to resolve the issue. If a decision cannot be made, the product demonstration judges will consult with the head judges, competition technical manager, and/or the competition coordinator to resolve the issue.

### 4.3 DESIGN & SAFETY CONSIDERATIONS

- The competition coordinators and host venues stress the importance of safety practices and procedures to all companies. The score sheets and rubrics will reflect the MATE Center's efforts to encourage and reward companies that demonstrate exceptional safety practices and procedures.

- **ALL ROVS MUST PASS A SAFETY INSPECTION CONDUCTED BY COMPETITION OFFICIALS PRIOR TO ENTERING THE POOL.** These inspections will be conducted topside to ensure that ROV systems meet the design and building specifications and do not pose a risk to the integrity of the event venue. See [VEHICLE DESIGN & BUILDING SPECIFICATIONS](#) for additional information.

**ROV MOTORS MUST BE WATERPROOFED!** No exceptions. You may use already waterproofed motors (bilge pump motors, etc.) or you may choose to waterproof small electrical motors.

- Propellers must be enclosed inside the frame of the ROV or shrouded. **Companies that have propellers protruding outside of their frame will not pass the safety inspection and will not be allowed to compete.**
- Cameras and monitors are permitted, but aren't needed as companies are allowed to look into the pool to pilot the ROV. If your company chooses to use a camera(s), the camera(s) and monitor must be powered off of the 12-volt battery or power supply provided by the contest organizers. **NO AC POWER IS PERMITTED WHATSOEVER.** In other words, you can't plug your ROV into a wall socket!
- Radio transmitters that operate on a separate battery are permitted. No batteries are permitted to be in or on the water. No exceptions. Note that although wireless controllers are allowed, MATE is not responsible for wireless interference. Adjacent wireless controllers with a battery that has a higher charge may "hijack" control signals. MATE will not stop the clock to resolve wireless control issues under any circumstance. Companies deciding to utilize wireless controllers do so at their own risk.
- Safety must also be a priority when operating your ROV poolside. Keep an eye out for tripping hazards. Make sure that your connections to the battery or power supply are not lying in pools of water on the deck. During your product demonstration, be sure to secure any equipment so that it does not fall, damage the deck, or cause injury.
- Loose fitting clothing, jewelry, and long hair could all become safety issues. Consider securing long shirts or baggy pants, removing jewelry, and tying back long hair when working on or operating your ROV.
- ROVs may be constructed out of materials of your company's choice, provided they meet the design and building specifications and safety regulations. Warning labels should be posted on potentially hazardous components of your ROV system.
- **Closed-toed shoes are required on the pool deck and anytime you are working on your ROV.** Safety glasses or goggles should be worn when working on your ROV.
- Personal flotation devices (PFDs) may be required when launching and recovering your vehicles. Contact [your regional coordinator or visit your regional contest's website](#) to determine whether this is

a requirement at your regional event. If PFDs are required, they will be provided by the regional coordinator.

## PART 5: ENGINEERING & COMMUNICATION

### **NOTE for 2021!!!**

MATE has created an ROV Competition [Marketing Kit](#) that includes logos and guidelines for their use.

The ability to communicate information about your vehicle and the design and building process is equally as important as how well your vehicle performs. Strong communication skills are an essential part of good business practices and one of the most in-demand skills in the constantly evolving, ever-changing workplace.

To emphasize this point, the competition requires the following four engineering and communication components:

- Company spec sheet
- Technical (written) documentation (Examples of spec sheets and technical documentation from previous competitions can be found at <http://www.materovcompetition.org/archiveshome>.)
- Engineering (oral) presentation (Examples of engineering presentations can be found on [MATE's Vimeo channel](#).)
- Marketing display

**NOTE:** Regional contests may not require all of the Engineering & Communication components. Contact [your regional coordinator or visit your regional contest's website](#) for more information.

See the [TIPS FOR EFFECTIVE WRITTEN AND ORAL COMMUNICATION](#) for additional information.

### **NOTE for 2021!!!**

Your company should refer directly to the scoring rubrics posted under [Scoring](#) for details on what is required for your technical documentation, engineering presentation, and marketing display. The judges will use the rubrics to evaluate and score these engineering and communication components.

### 5.1 COMPANY SPEC SHEET

The purpose of the company spec sheet is to provide the judges with a “snapshot” of your company. It includes basic information about your company and vehicle.

Company spec sheets will be reviewed by MATE competition coordinators. Companies will receive up to 20 points for submitting a spec sheet that is **one page** in length, follows the file size and naming specifications, and contains **all** of the following information:

## COMPANY SPECS

- **Company and school, club, or community organization name**
- **Home state and/or country**
- **Distance required to travel to the world championship**
- **History of MATE ROV competition participation.** Be sure to specify if your company and/or the members of your company are “new” or “returning.”
- **Company photo and caption indicating members’ names and roles (e.g. CEO, CFO, Design Engineer, Pilot, etc.).** This photo should include all of the members of your company.
- **Range of grade/college levels represented by the members of your company**

## ROV SPECS

- **ROV name** if applicable
- **Total cost.** You must include the approximate cost of any donated items.
- **Size and weight measurements**
- **Total student-hours to design and build.** This should include the number of hours that each and every member of the company worked on the vehicle.
- **Safety features**
- **Special features**
- **Photo of the vehicle**

**REMINDER!!!** If all of the above information is included, the specifications for length, size, and naming conventions are followed carefully, and the document is submitted on time, this is an “easy” 20 points! You can find the company spec sheet scoring rubric posted [here](#).

## 5.2 TECHNICAL DOCUMENTATION

The purpose of the technical documentation is to challenge you to effectively and efficiently communicate information using clear and concise text along with graphics, illustrations, and data that add to and complement (and not distract from) the information. Your company must organize and present the information in a way that is logical and complete. The document should focus on the technical and safety aspects of your ROV/ROV systems, innovations (“hacks, tips, and tricks”), and include a profile of your company and staff. You should consider this document a reference for both judges and future team members (part of the company’s institutional knowledge).

Your company’s technical documentation will be reviewed and evaluated by a panel of working professionals – individuals who represent science, exploration, government, and industry.

Each judge on the panel will award a score (50 points max). Judges’ scores and comments will be returned to you shortly after the event.

**NOTE: The judges will not review and rescore revised versions of your technical documentation during the competition. Use the technical documentation scoring rubric posted [here](#) as the guideline for the required components for the technical documentation. This rubric will be posted by March 1, 2021. In the meantime, companies may refer to the previous year’s rubrics posted [here](#) for a general idea of the categories and points.**

### 5.3 ENGINEERING PRESENTATION

The purpose of the engineering presentation is to challenge you to effectively and efficiently communicate information with words and “props” (i.e., the ROV). Your company must organize and present the information in a way that is logical and covers the development and testing of your ROVs and the formation and development of their team. The presentation should be delivered as a “technical brief.” The presentation is the opportunity your company has to 1) communicate directly and in person your critical thinking, creativity, and engineering reasoning and 2) demonstrate your individual and collaborative contributions to the creation of the vehicle.

During the competition, your company will have 5-10 minutes deliver your presentation to a panel of working professionals – individuals who represent science, exploration, government, and industry. After the presentation, the judges will take 5-10 minutes to ask the members of your company questions about your ROV. The judges will evaluate both your presentation and responses to their questions. Each judge on the panel will award a score (50 points max). Judges’ scores and comments will be returned to you shortly after the event.

**All student members of your company must be prepared to participate in the presentation and question and answer (Q&A) period.** You are required to have your ROV with you. During the Q&A, all members of the company should be prepared to answer. However, if one student is better able to answer a specific question, the others may pass the question to that student to answer. For example, if a judge calls on the pilot to answer a question about the tether, the pilot can respond by informing the judge that the tether manager was the lead on that system and allow the tether manager to answer without penalty or loss of points.

**NOTE:** The engineering presentation is designed to be a face-to-face interaction where students and representatives from industry become engaged in conversation. MATE will not provide audio visual aids, such as slide projectors, computer projection screens, white boards, etc.; however, you are welcome to distribute handouts to help judges better understand the information that you are presenting. Electronic forms of presentation (e.g. PowerPoint or Keynote slides) **are NOT permitted.**

**Instructors, mentors, family members, friends, and members of other companies are permitted to attend.** However, we ask that those in attendance be respectful and courteous throughout the presentation and follow-up question and answer period. Be mindful that this presentation may be a stressful time for the students. If the room becomes crowded or the spectators become distracting, it is up to the judges’ discretion to request that some or all spectators leave the presentation. **While they are permitted to attend, instructors and mentors are not allowed to participate.**

Use the engineering presentation scoring rubric posted [here](#) as the guideline for the required components for the engineering presentation. This rubric will be posted by March 1, 2021. In the meantime, companies may refer to the previous year's rubrics posted [here](#) for a general idea of the categories and points. Judges may ask questions regarding any of these topics not covered in the presentation as well as other questions about the vehicle, the mission theme, or the company.

### Preparing for your engineering presentation and Q&A

- Make sure that every member of your company has a good, general working knowledge of your vehicle, even though they may have specialized in one specific aspect of its design and construction.
- Encourage each member of your company to keep a project notebook. Before the competition, set up a time where you compare notebooks. One member might have written more information about your ROV's electrical system, while another might have included details about buoyancy that others forgot. This exercise will help to refresh everyone's memory about the design and building process. If your company submitted technical documentation, make sure that all company members have read and are familiar with it. This exercise will help to familiarize everyone with all aspects of the project.
- Generally, you will have more to say about your ROV than can be presented in 5-10 minutes. That is why it is critical to organize your material and practice communicating it. However, avoid coming across as having memorized your presentation verbatim. Judges want to see that you are prepared and understand the information, not that you can simply regurgitate a rehearsed speech from memory. Ask your instructors or mentors to give you feedback.

### Other important items

- If during the engineering presentation it becomes apparent that instructors, mentors, and other adults associated with your company exercised more than an advisory role, judges reserve the right to deduct points or, in extreme cases, disqualify companies.

## 5.4 MARKETING DISPLAY

The purpose of the marketing display is to challenge you to present technical information in a way that appeals to and is understood by a non-technical audience. It is the promotional piece – you must not only present information about your ROV and your company, but you must also use graphics and design to publicize and “sell” (convince viewers of their value and excellence) your products and people.

During the competition, your company's display will be evaluated and scored by a completely different group of working professionals – individuals who will represent science, business, government, industry, and education/outreach.

While some judges will have a technical background, others will have a communications, marketing, or public relations background. In addition, there will be visitors to the competition who may not completely understand what an ROV is or how it is used. Think of these visitors as potential future clients who may authorize funding for your work, but have a limited understanding of the technology (i.e., you need to explain

your technology, the tasks at hand, and “sell” them on YOUR products and services). Design your display to communicate to this type of audience.

Each judge will award a score (50 points max). Judges’ scores and comments will be returned to you shortly after the event.

Each company will have a space approximately 3-feet x 3-feet for its display. Depending on your regional, tables may or may not be provided. Contact [your regional coordinator or visit your regional contest’s website](#) for more information.

**Use the marketing display scoring rubric posted [here](#) as the guideline for the required components for the marketing display. This rubric will be posted by March 1, 2021. In the meantime, companies may refer to the previous year’s rubrics posted [here](#) for a general idea of the categories and points.**

#### **Creating an effective marketing display:**

- Address the theme and make real-world connections.
- Reflect your company’s personality and mindset.
- Make key points and be concise.
- Keep the general public in mind.
- Make sure to label any and all figures, graphs, diagrams, and photographs and credit the source.
- Maximize the use of the 36” by 48” display space.
- Make sure that it is both informational and aesthetically pleasing.

**Note:** “Accessories” such as video footage, PowerPoint slide presentations running on laptop computers, video projections, etc. are permitted but should be used with discretion. Remember that the judges will have a limited amount of time to evaluate your marketing display and may find excessive use of audio or video presentations distracting.

However, if you do make a video of your ROV building or competition experience, please submit information about it to the [MATE ROV Competition officials](#) so that it can be shared via MATE’s YouTube and Vimeo channels.

## **5.5 CORPORATE RESPONSIBILITY**

The MATE ROV Competition uses underwater robotics to inspire and encourage students’ interest in STEM (science, technology, engineering, and math) education and careers. Recognizing that the students who participate in MATE competitions are powerful ambassadors for the program as well as effective leaders in raising awareness of important issues and bringing about positive change, companies have the opportunity to earn up to 10 points for “corporate responsibility.”

Corporate responsibility includes, but is not limited to, the following:

- **Mentoring** consists of, for example, providing guidance to other students in your area who are designing and building an ROV for the competition or a science or other project.

- **Engaging the community** includes demonstrating your ROV and sharing information about your company at festivities and other community-wide events. Presenting to a Rotary Club or your school districts board of directors are other examples.
- **Media outreach** consists of:
  - o Developing a list local media contacts
  - o Writing a press release about your participation in the MATE ROV competition
  - o Distributing it to your media contacts
  - o Following up with your media contacts to see if they're interested in your company and its ROV
  - o Compiling a summary of results

Here are some [general guidelines](#) for working with the media. They are specific to the world championship, but can be easily modified for regional events.

- **Raising awareness of environmental, social, and governance (ESG) issues. Just look at this year's theme and product demonstration tasks for ideas – from removing plastic pollution from our oceans to assessing the health of ecosystems impacted by climate change and creating habitats to promote species diversity.**
- Corporate responsibility efforts will be reviewed by competition coordinators and awarded 0 to 10 bonus points, depending on the number and scope of the outreach and awareness activity(s), i.e., the number of other students or members of the community engaged, the number of mentoring sessions, etc.

Make sure to include the following information in your write-up:

- Type of activity (e.g. mentoring, exhibiting at a community event, raising awareness)
- Locations, dates, and the amount of time spent on the activity
- Number of students or community members (if a large event, this can be an approximate) involved
- Description of your actions, outcomes, and other information that helps to demonstrate the quality of your time and efforts
- For media outreach, please submit a copy of your press release, a copy of your media contacts list, and a summary of news articles, TV or radio coverage, etc. that your company received. Include copies of articles and URLs, and list any television or radio coverage. Be sure to include name of outlet, date, and a summary of the coverage.

### TIPS FOR EFFECTIVE WRITTEN AND ORAL COMMUNICATION

Communicating ideas about how to solve a problem and evaluating those ideas against alternative ideas is a critical skill for anyone entering the workplace. It is a skill that is directly linked to decision making about whether or not to hire (or fund) us and our ability to have a say in the work that we do.

The key to a successful technical documentation and engineering presentation is the way that critical thinking and engineering reasoning are communicated. You can think of the process as technical “storytelling.”



Technical storytelling includes the use of text, images, schematics, and data to communicate the “story” of how your company brainstormed and evaluated ideas to come up with your solution (e.g. ROV, payload tools, and operational strategies) to the problem at hand (product demonstration tasks). It also involves organizing information to efficiently present your work and justify why you did what you did.

However, you should choose details with care. Each detail should help to answer the question "why is what you did the best solution for your company and for this competition?" Describe why a component in the system is important and how you chose it. Include specifications or dimensions only if they help to explain the “why” and “how” you made choices. Keep in mind that a mechanical drawing with dimensions can replace a lot of text and in many cases do a better job telling details of the story than text.

That said, if something is hard to describe clearly and completely with two to three sentences, consider whether using an image may help. A good technical document balances text and images to provide lots of information in a concise way, which helps give readers a detailed understanding while being quick and easy to read. Remember that your reader is new to your design and needs to understand both what your design is and the process you used to get there. Present text and images in a logical order that helps readers follow your design and building process and results.

Maintaining a project notebook is a good business practice that will help to capture ideas and document your company’s progress – including your research, designs, trade studies, experiments, data, vehicle specifications, testing, expenditures, and donations. The notebook is also a place to keep track of your company member’s contributions (time, support, etc.).

Along with your notebook, here are some items to consider as you prepare to tell your story:

- What was your company’s "work breakdown structure" (tasks, time, and people)?
- What were the greatest constraints (schedule, budget, equipment, labor, logistics, etc.) on your design process?
- How did the product demonstration tasks and rules influence your design and decisions?
- What process did you use to evaluate different design solutions?
- What were the most important design decisions you made and why?
- How did you arrive at your final power budget? What trade-offs, if any, did you have to make and why?
- How do you calibrate your sensors?
- If your vehicle uses software, where does the code execute? Describe the flow and format of the data.
- Did you have a major troubleshooting experience? Any problem or procedure that takes more than 20 minutes to figure out is worth understanding and writing down.

## PART 6: DOCUMENTATION

Companies are required to submit a system interconnection diagram (SID) of their vehicle control system. Your regional may also require you to submit technical documentation and a company spec sheet.

Contact [your regional coordinator or visit your regional contest's website](#) to determine what documentation must be submitted for your regional and the date it is due.

DOC-001: Technical documentation: A technical document or engineering notebook about your vehicle that will be reviewed by a panel of judges. See the [technical documentation](#) section for more information on the contents required for the technical documentation.

DOC-002: Company spec sheet: A one page document that provides a snapshot of your company and ROV. See the [company spec sheet](#) section for more information on the requirement for the company spec sheet.

DOC-003: SID Electrical: Companies must provide a [system interconnection diagram \(SID\)](#) of their vehicle control system during their safety inspection.

DOC-004: Fluid power SID: Companies using fluid power (hydraulics or pneumatics) must provide a fluid power diagram. The diagram should separate and show what systems are on the surface and what systems are on the vehicle. A fluid power SID for simple syringe hydraulics would consist of a syringe box on the surface connecting to a syringe box on the vehicle.

The fluid power SID can be incorporated into the Electrical SID or can be a separate, one page document.

DOC-005: Documents may be due before the competition or the day of the competition. Regardless, companies **MUST** bring a SID of their ROV systems in order to pass the safety inspection!

NOTE: By submitting your documentation, you are giving the MATE Center permission to publish these documents on its web site.