

TECHNICAL REPORT



Eastern Edge Robotics Team

Marine Institute and Faculty of Engineering of Memorial University

2008 MATE International ROV Competition

Explorer Class

ROV Pontus

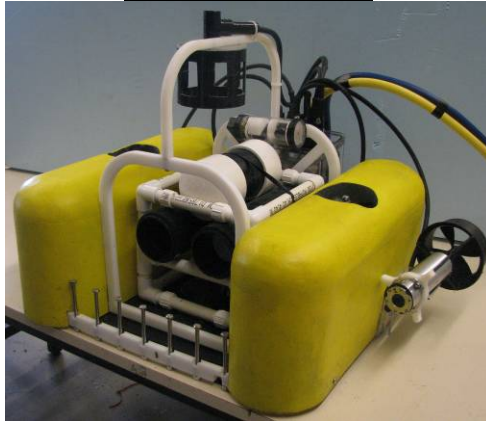

Team Members

Jake Bragg, Leanne Brockerville, Trevor Brown, Cait Button, Stephen Crewe, Gina Doyle, Mark Flynn, Matthew Follett, Scott Follett, Mikhail Freeman, Andrew Furneaux, Justin Higdon, Nancy Hillier, David Hornell, Jonathan Howse, Adam Lewis, Pam MacNeil, Matthew Minay-Goldring, Chris Neville, Joseph Pennell, Wally Picco, Renée Quick, Devin Walsh, Erin Waterman, Jonathan Watson

Mentors

Dwight Howse, M. Eng., M.B.A.
Clar Button, B. Sc, M. Sc.
Thomas Donovan, B.A., B.Ed., Dip. Tech. Ed.
Diane Howse, B.Ed., B.Sp.Ed., M.Ed

ABSTRACT

This technical report describes the ROV *Pontus*, built by the Eastern Edge Robotics Team to compete in the 2008 MATE International ROV Competition. The process of building the ROV and traveling to the MATE Competition cost approximately \$60,000, including the value of donated materials. Two pontoons connected by High Density Polyethylene (HDPE) frames are the basis of the chassis, which also has four 24 V thrusters and a stereoscopic camera. The chassis has two latches to hold and lift an OBS platform, and a thermistor to record temperature of a venting fluid. The control system was programmed in C# and runs using seven threads that sample data continuously. The onboard electronics system is inside polycarbonate housing, and is connected to the surface using a custom-built tether. The topsides electronics consists of a joystick and a control unit. To build the ROV, the team learned new technical skills, like fiberglassing and programming PIC controllers. They learned that some of the best ideas come from group discussions, where everyone can contribute to all aspects of the design process. *Pontus* was designed using inspiration from projects that explore mid-ocean ridges. It was built to perform tasks relevant to exploration of ridges and deep-sea vents, such as collection of damaged equipment, specimen samples and information about environmental conditions.



Figure 1. Eastern Edge Robotics Team 2008

Left to right: Jonathan Howse, Mickey Freeman, Chris Neville, Wally Picco, Pam MacNeil, Justin Higdon, Matthew Follett, Cait Button, Erin Waterman, Leanne Brockerville (in tree), Gina Doyle, Mark Flynn, Jonathan Watson, David Hornell (in front), Scott Follett, Adam Lewis, Trevor Brown.



TABLE OF CONTENTS

ABSTRACT.....	ii
TABLE OF CONTENTS.....	iii
1. BUDGET AND FINANCIAL STATEMENT	4
2. DESIGN RATIONALE.....	5
2.1 Structural Frame.....	5
2.1.1 pontoons.....	5
2.1.2 Buoyancy	5
2.2 Propulsion	6
2.3 Camera	6
2.4 Tether	7
3. CONTROL SYSTEM.....	7
3.1 Software Engineering.....	9
3.2 Control System Tabs.....	9
3.2.1 Operations	9
3.2.2 Pre-dive Checklist.....	10
3.2.3 Configuration	10
3.3 Camera Programming	10
4. ELECTRONICS	11
4.1 Topside Control Unit	11
4.2 Submarine Electronics Can.....	11
5. PAYLOAD TOOLS.....	12
5.1 Task 1: Free an OBS from the seafloor	12
5.2 Task 2: Collect up to 3 samples of lava	13
5.3 Task 3: Measure the temperature of hydrothermal vent fluid.....	13
6. CHALLENGES	14
7. TROUBLESHOOTING TECHNIQUES.....	15
8. FUTURE IMPROVEMENTS	15
9. LESSONS LEARNED/SKILLS GAINED.....	16
10. REFLECTIONS ON THE EXPERIENCE.....	17
11. DESCRIPTION OF A PROJECT THAT USES ROVS TO STUDY MID-OCEAN RIDGES	18
12. ACKNOWLEDGEMENTS	20
APPENDIX A – FLOW ANALYSIS.....	21
APPENDIX B – ELECTRICAL SCHEMATICS	23



1. BUDGET AND FINANCIAL STATEMENT

Table 1. Total cost of materials and travel to competition

ITEM	DONATIONS (Value \$CAD)	PURCHASES (Cost \$CAD)
<i>Polycarbonate electronics can</i>		250.00
<i>Electronics housing</i>		250.00
<i>Styrofoam</i>		43.00
<i>Fiberglass and epoxy</i>		270.00
<i>Hardware (fasteners, drill bits, etc.)</i>		200.00
<i>24 V Thrusters - Inuktun (4 @ \$ 2000)</i>	8000.00	
<i>Fiber-optic tether - Leoni Elocab</i>	1200.00	
<i>Cameras (2 @ \$120)</i>		240.00
<i>Stereovision i-glasses</i>		250.00
<i>Analog input board</i>		150.00
<i>Servo controller (1 @ \$50)</i>		50.00
<i>Fiber-optic interface board – Focal Tech</i>	3500.00	
<i>Pulse width modulator (6 @ \$250)</i>		1500.00
<i>Misc. electronics components</i>		300.00
<i>Pressure Sensor – Keller America</i>	575.00	
<i>Digital Compass</i>		300.00
<i>Group airfare (25 people @ \$1064)</i>		26,600.00
<i>Accommodations, meals, ground transportation (25 people @ \$650)</i>		16,250.00
TOTAL		\$59,928.00

Table 2. Total contributions to Eastern Edge Robotics Team

CONTRIBUTIONS	VALUE (\$CAD)
<i>Faculty of Engineering, Memorial University</i>	10,000.00
<i>Marine Institute</i>	5000.00
<i>Summer Robotics Camps</i>	9928.00
<i>Individual contributions (22 people @ \$1000.00 each)</i>	22,000.00
<i>Misc. donated materials from previous years</i>	13,000.00
TOTAL	\$59,928.00

2. DESIGN RATIONALE

2.1 Structural Frame

2.1.1 pontoons

The main structural components of the ROV are two pontoons, which provide buoyancy and help accomplish the required tasks (Figure 2). The team designed the pontoons using SolidWorks 3-D CAD (Figure 3) and milled a form from High-Density Styrofoam using a CNC router. The team then molded fiberglass around the Styrofoam, and removed the Styrofoam from inside the hardened fiberglass casing. A vertical thruster in the center of each pontoon separates each pontoon into two independent chambers. Excluding the space taken by the thrusters, each pontoon has a volume of 10 L. On the outside of each pontoon, a horizontal thruster is mounted using HDPE brackets. The pontoons are joined by two 1.27 cm ($\frac{1}{2}$ ") HDPE frames, one forward and one aft, so that one pontoon is port and the other starboard. The aft frame has a mount on it for the onboard electronics can. The frame is designed so that there is a gap between the pontoons to accommodate the OBS platform that will be attached during the missions. When the ROV is lowered onto the OBS platform, the pontoons will sit on either side of it. See Appendix A for a fluid dynamic analysis of the chassis.



Figure 2. pontoons with HDPE frames

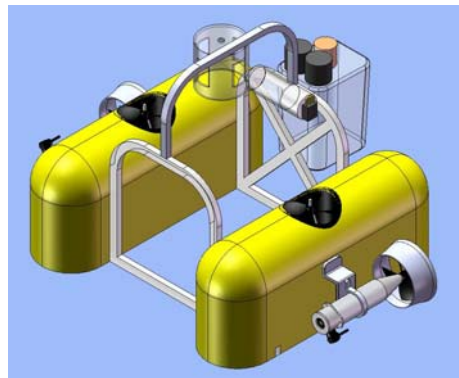

Figure 3. ROV drawn with SolidWorks

2.1.2 Buoyancy

The team developed the 'LUNG' (Load Unifying Neutral Gravity) system to adjust buoyancy on the ROV. This is a pneumatic system, designed to bring objects to the surface. The first task requires the ROV to bring an OBS platform to the surface, which it will accomplish by latching onto the OBS. When the ROV latches on, a scuba tank on the surface sends a regulated air stream to the four pontoon cavities, providing positive buoyancy. The cavities have a combined fill space of 20 L, which can provide 196 N of positive buoyancy when filled. With all weights from the OBS aboard, the pontoons can still provide 131 N of positive buoyancy, allowing the ROV to return to the surface quickly. The system utilizes standard 0.64 cm ($\frac{1}{4}$ ") NPT fittings to provide air flow to the pontoons. The air in

the scuba tank is initially at approximately 20,684 kPa (3000 psi). It is regulated through a primary stage regulator to about 792 kPa (115 psi) and then to 275 kPa (40 PSI) through a second stage regulator. The air travels through a 0.95cm (3/8") hose with a check valve, which prevents water from traveling up the hose, and into three double manifolds, splitting the air into 0.64 cm (1/4") hoses that bring air to each of the compartments. At the end of each hose, a valve adjusts the airflow into each compartment, allowing for equal distribution.

Both pontoons are open on the bottom, to accommodate air expansion as the ROV rises. Strategically placed holes on the forward and aft ends of each pontoon allow air to escape if the ROV leaves the horizontal plane, balancing the air volume. At the top of each pontoon, extruded Styrofoam provides additional buoyancy and structural support, helping to maintain neutral buoyancy. This system is efficient because it allows the ROV to utilize itself as a tool to surface the OBS and return all weights to the surface.

2.2 Propulsion

For propulsion, the ROV uses four 24 V, 90 W Inuktun thrusters, each with a depth rating of 300 m (Figure 4). The thrusters have standard EO connectors and are liquid filled with "Enviro-Rite™" fluid for pressure compensation. Two of the thrusters are placed vertically inside the pontoons, and two of them are mounted horizontally, one on each pontoon. The team is in the process of designing brushless thrusters, which will not be complete for this year's competition. See Future Improvements for a discussion of this.



Figure 4. Inuktun thruster

2.3 Camera

The primary camera source is a stereovision system, comprised of two RHPC-900 0.64 cm (1/4") high-resolution color board cameras (Figure 5). The cameras are linked by a genlock line, which synchronizes their frame rates. A PIC controller receives an RS-232 signal from the topsides computer to select the left camera, right camera or stereovision. If stereovision is required, an RS-232 signal tells the PIC to alternate fields from the left and right cameras to a single video output. This signal is deciphered on the topside by a virtual reality headset from Virtual i•O™. Both panels of the headset have 180,000 pixel resolution and display a 30° field of view, with 100% stereo overlap. The glasses provide 3D flicker-free stereoscopic imaging.

A High Density Polyethylene (HDPE) sled acts as the mounting system for the cameras, holding the cameras in place with setscrews. The camera mount was machined from 7.62 cm (3") HDPE stock to a diameter of <5.08 cm (<2") for a machined fit inside the Lexan tube it was assembled in. The <5.08 cm (<2") stock was then milled to the appropriate length to satisfy all the camera components. This ensures proper alignment of the cameras for optimal 3D

vision, as any misalignment would distort the 3D effect. The HDPE sled separates the cameras from two super-bright LED boards, which each contain 16 PWM-controlled LEDs. This provides a variable light source for the cameras, so that the ROV can operate in low light settings. The HDPE sled is attached to a servo mount, on which the whole camera system tilts over a range of 150°. This vertically variable focal line gives the pilot a higher range of sight during the mission. An RS-232 signal through a PIC controller controls all the features of the camera system, including tilt angle, LED brightness and display of either stereovision or solely the left or right cameras. This system was designed to add depth perception during ROV operation. The aim in designing this system was to enhance realism and performance throughout the mission and to gain experience in alternative vision methods.



Figure 5. Stereovision camera system

2.4 Tether

The ROV operates using a custom built tether that was designed by the team to meet their needs and donated by Leoni Elocab Inc. of Kitchener, Ontario, Canada. The outer portion of the tether has a low drag polyurethane coating, designed to make the tether neutrally buoyant in fresh water. The tether has two 12-gauge copper wires to transmit DC power, and two multi-mode fiber-optic strands for control and video signal transmission. One of the fiber-optic strands is redundant, and will only be used if the other gets damaged. Attached to this tether is a 0.95 cm (3/8") I.D. air hose for the LUNG system.

3. CONTROL SYSTEM

Pontus has a control system that was programmed using the C# language. The program is run on a notebook PC and uses DirectX to read user inputs and to provide drawing capabilities. The inputs from the joystick and mouse are monitored and appropriate output responses are calculated. The C# control system was designed as a multi-threaded program (or integrated segments), which can sample data continuously. Our programming flow chart shows the logic behind our control system (Figure 6).

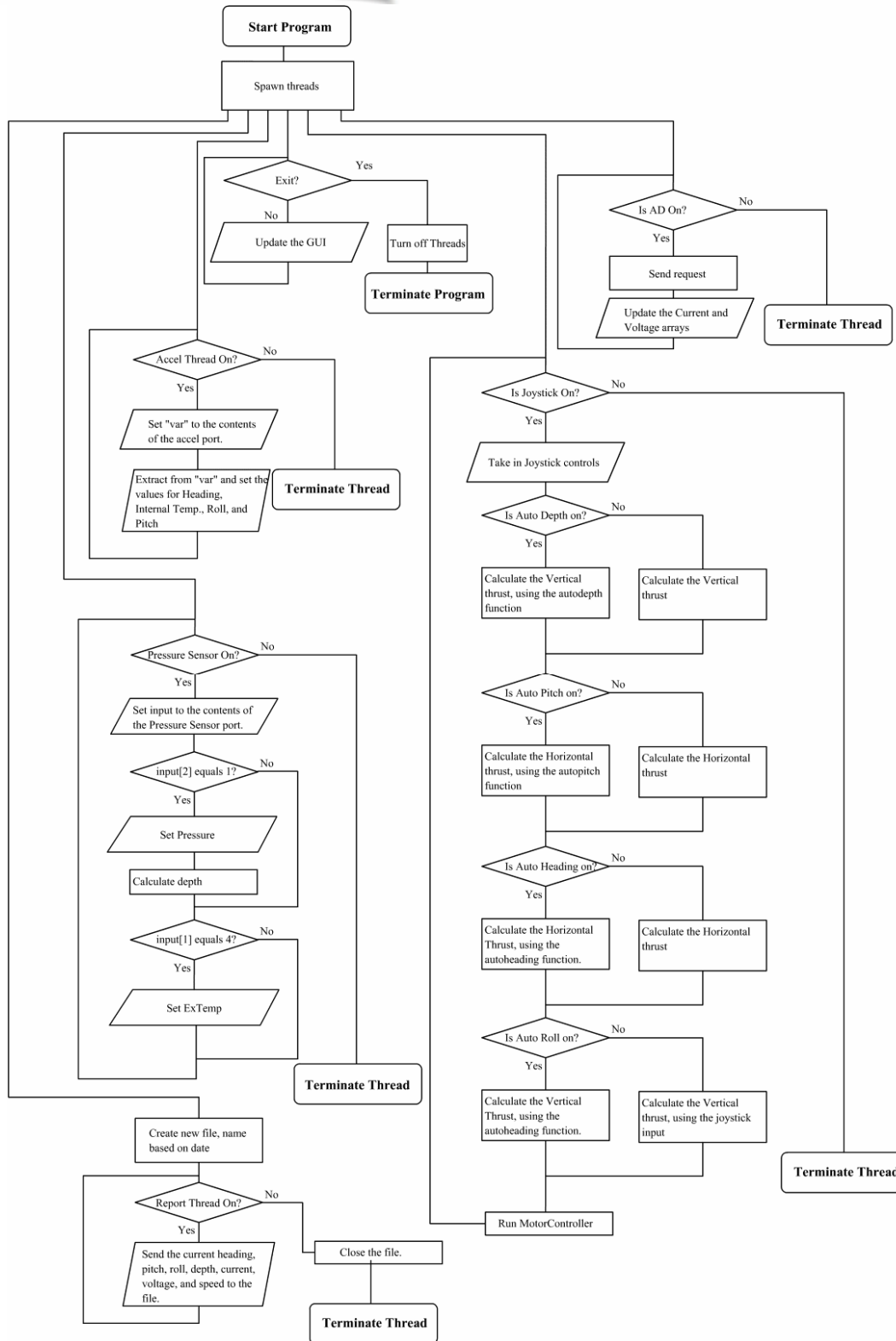

Figure 6. Programming flowchart



The threads in our program are:

- Analog/Digital Converter signal processing thread, for all sensors and power supply monitoring
- Joystick monitoring, to take in joystick information and update the thrusters and control system appropriately
- Thruster control, to send out updated values to the thruster and motors
- Accelerometer thread, which reads and displays values for pitch, roll, and heading, as well as temperature within the electronics can on the ROV
- GUI thread, which updates the visual representation of the ROV, both on the computer screen and the video display
- Collections thread, responsible for taking updated values from other threads and bringing them into the ROV software
- Report thread, which keeps detailed information on the status of the ROV and records the values for post-mission debriefing and review

Thread design increases processing speed by utilizing multi-core or multiple processors and allowing multiple threads to run simultaneously. Resources need to be allocated carefully, as multiple threads trying to access the same resource or variable at the same time could corrupt the information. Therefore, each physical device is dedicated to a single thread, and there is no overlap in resources.

3.1 Software Engineering

The control software was designed with the idea of breaking the program into modules. This approach allows for changes in the program's devices or settings by changing a single line of code. For example, to change the thruster placement of the ROV, you would write a new subclass of the ThrusterControl class, and change the ROV class construction from the old one to the new one. This approach allows for quick and easy changes to the software, and allows for development of a library of classes that can be used with an ROV that follows this design pattern.

3.2 Control System Tabs

Pontus' Control GUI has been divided into multiple sections called tabs. Each tab has a role in ROV operations or information display. These sections are: Operations, Pre-Dive Checklist and Configurations.

3.2.1 Operations

The Operations tab presents all data required for the ROV to operate. The functions included are: mission time, camera tilt position, thruster power, power supply monitoring, and humidity and temperature in the electronics can (Figure 7). An artificial horizon displays pitch and roll. A digital compass shows heading and monitors the number of turns in the ROV tether, beneficial for tether management purposes. The control system incorporates an auto-depth feature that can be used to maintain or move to a pre-selected depth.

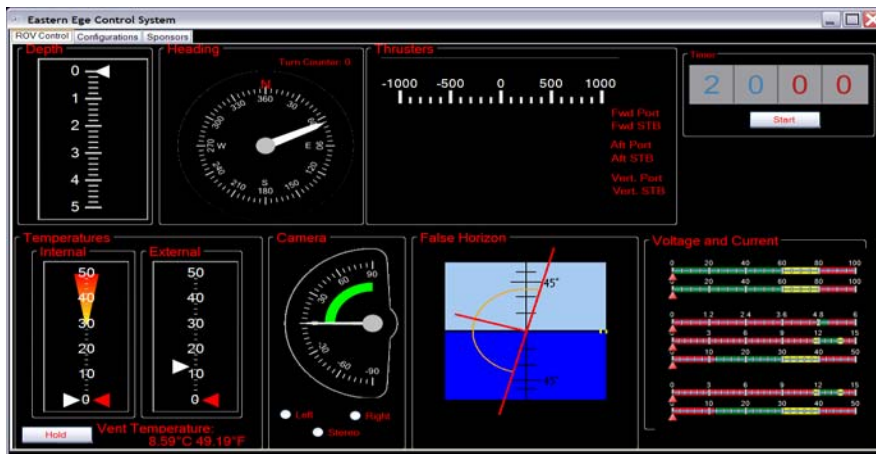

Figure 7. ROV Control Tab

3.2.2 Pre-dive Checklist

The Pre-Dive Checklist ensures that all safety and runtime checks are completed before launching the ROV. As well, ambient air pressure is measured for use as an offset for the depth sensor. This checklist is read by the pilot before the ROV is launched, ensuring that all safety issues are addressed.

3.2.3 Configuration

The Configuration tab provides a mechanism to adjust *Pontus* during a mission. It allows for real time adjustments to each motor by changing that motor's particular job, and determines whether each motor needs to undergo negative rotation. It also allows for adjustments of the auto-feature coefficients, and of water density for depth calculations.

3.3 Camera Programming

The goal of the camera program was to achieve stereo vision. To do this, several things were needed:

1. A 60 Hz signal to be used as a genlock to synchronize the signals of the two cameras that provide the two points of view;
2. A camera selection signal that selected right or left camera or could be alternated at 30 Hz for stereo vision;
3. A radio-control standard 1-2 ms controllable width pulse repeating every 16 ms to control a servo that controls the tilt of the cameras;
4. A variable duty cycle pulse to control light level of the two LED arrays

In order to implement this capability, a MicroChip PIC18F1320 microcontroller was used in conjunction with a SN744066N video switch. The PIC was programmed in assembly language and external control was provided

over an RS-232 link. The single-byte control protocol provides for 7 bits of tilt control (128 positions), 6 bits of light level control (64 light levels), and 2 bits of camera selection control (left, right, or stereo).

4. ELECTRONICS

The electronics system is divided into two components: the topside control unit (Figure 8) and the submarine electronics can (Figure 9). Refer to Appendix B for Electrical Schematics of the topsides unit, submarine unit and cameras.



Figure 8. Topside control unit



Figure 9. Submarine electronics can

4.1 Topside Control Unit

The topside control unit provides: power interconnections, monitoring, protection, an interface to the PC through USB ports, video overlay, and communication with the ROV over a fiber-optic tether. From here, power is supplied to all electronics at a nominal +24 V DC. Voltage, current, and internal temperature of the control unit are monitored and displayed using a Phidgets 8/8/8 interface with eight channels of 0-5 V A/D conversion, eight channels of digital output and eight channels of digital input. Control of the ROV is handled through the USB ports of a PC. One USB port is used to connect a joystick and the 8/8/8 interface to the PC, and a second port is used to connect a Quatech Technologies 8-port RS-232/422/485 device. Each port on this device is configurable as either RS-232, 422, or 485. *Pontus* is configured with six RS-232 control channels and two RS-485. One RS-232 line is used to control a video overlay board to display real-time information such as depth and heading on the display monitor. Four RS-232 channels and two RS-485 channels are interfaced to the ROV through the console unit of a Model 907 video/data multiplexer from Focal Technologies. This unit allows for communication of the three video channels over a single fiber strand.

4.2 Submarine Electronics Can

The onboard electronics are located in a waterproof polycarbonate can purchased from Prevc^o, with a 75m depth rating and dimensions of 9.35 x



12.06 x 19.99 cm. The can is located between the two pontoons, and the tether connects to it using a custom-machined brass penetrator. The onboard electronics are connected to external equipment such as thrusters, cameras and sensors by two multiple-plug, segmented bulkhead connectors from SeaCon-Brantner

The submarine electronics component consists of several units. The remote unit of the Model 907 video/data multiplexer conveys optical signals through the tether and converts them to video and data electronic signals. RS-232 signals are received from the topsides electronics by a Pololu 8-channel servo controller. This allows each thruster to have independent proportional control by activating six individual IFI Robotics Victor HV pulse width modulators.

Pontus has several onboard analog sensors, which allow monitoring of conditions inside the can. Voltage is monitored by an 11-channel analog-to-digital converter from B&B Electronics. The converter is connected by an RS-232 bus and has 12-bit resolution over a 0-5V range. It also samples the external temperature sensor to monitor the venting fluid. Internal temperature of the can is monitored to ensure that components inside the can are not overheating. Temperature is measured by a Microchip TC1047A sensor that can record temperatures from -40 to +125°C. Relative humidity is measured inside the can to inform the operator of condensation buildup or water leakage. It is measured using a Humirel HTM1735 sensor, which will record humidity from 10-95% rH.

Another sensor inside the can is an OS-1000 digital compass from Ocean Server, which communicates over an RS-232 bus. It provides the ROV with a heading that is relative to magnetic north. The compass provides a feedback signal for auto-heading. Pitch and roll are measured by an integrated two-axis accelerometer and displayed on the topside computer monitor as an artificial horizon function. The accelerometer also provides for an additional temperature sensor in the electronics can.

The ROV uses a Preciseline™ pressure transducer from Keller America to determine water depth. It is located onboard the ROV outside the electronics can and communicates with the topside computer over an RS-232 bus. The transducer has a floating isolated piezo-resistive sensor, which gives $\pm 0.1\%$ depth accuracy, and 16-bit internal digital error correction. The transducer can measure water depths up to 20 m, as it is referenced to a vacuum and configured with a full range of 300 kPa. An auto-depth function is featured in the control system, and was programmed using the transducer's $\pm 0.1\%$ accuracy. The pressure transducer also allows for measurement of external water temperature.

5. PAYLOAD TOOLS

5.1 Task 1: Free an OBS from the seafloor

The team had several initial design ideas to release the OBS from the seafloor. Their first set of designs and prototypes involved using an inflatable bladder to lift the OBS from the seafloor. This would be done by laterally driving



the ROV into the OBS, using an arm to latch onto the base of the ROV, and then inflating bladders on all sides of the OBS, lifting it to the surface. The team decided that this design would be unstable, and instead focused on incorporating buoyancy into the chassis itself, so that their tool would only have to attach to the OBS and then the chassis could provide lift.

To lift the OBS from the seafloor, the ROV uses two latches located on the pontoons to attach to the base of the OBS. One latch is mounted on each pontoon, which will allow the OBS to slide into place as the ROV is lowered onto it. When the OBS is fully inside the hole in the center of the chassis, the latches snap into place underneath it, preventing it from moving when the ROV surfaces. The pilot can then fill the pontoons with air, providing buoyancy by displacing water. This brings the ROV and OBS to the surface in a controlled ascent, meaning that the OBS can surface with the lava still attached to it. The chassis is designed so that an appropriate height of OBS will break the surface of the water along with the ROV.

5.2 Task 2: Collect up to 3 samples of lava

Initially, the team planned to use an arm with a four-function manipulator to collect lava samples. The manipulator would have a mesh collection pouch for the required lava samples. This idea was abandoned when the team decided that they were going to lift the entire OBS to the surface using the chassis, as this design allowed them to lift the lava pieces along with the OBS. Using the current design, the lava samples will be removed from the OBS once it reaches the side of the pool under control of the ROV. A retractable skirt is attached to the inside edge of the pontoons, accommodating any obstructions that could block the ROV from getting in position. The skirt of the ROV holds the lava pieces in place, preventing them from sliding off the OBS during ascent.

5.3 Task 3: Measure the temperature of hydrothermal vent fluid

The team had two initial ideas on how to measure the venting fluid: using a thermocouple, or using a thermistor. The thermocouple would allow us to measure temperature based on the thermoelectric properties of two metals. Instead, we decided to use a thermistor, for several important reasons: they have a lower mass, they take faster and more accurate temperature readings, and because we already owned one.

We measure the temperature of the venting fluid using a Negative Temperature Coefficient (NTC) thermistor purchased from General Electric, and an amplifier that was custom designed and built by the team. Thermistor part #MC65F103A measures temperature using a voltage divider as input to an INA122 instrumentation amplifier, set with a gain of five. This produces a voltage between 0-5 V for a temperature range of 0-58°C that the A/D converter can read. The thermistor is located inside a PVC 'T', which is positioned so that the fluid will flow directly past the thermistor. The PVC pipe is mounted in the center

of the ROV, above the surge axis. When the ROV is lowered onto the vent, a pipe on the bottom of the ROV guides the temperature sensor into place, preventing the vent fluid from mixing with the exhaust water.

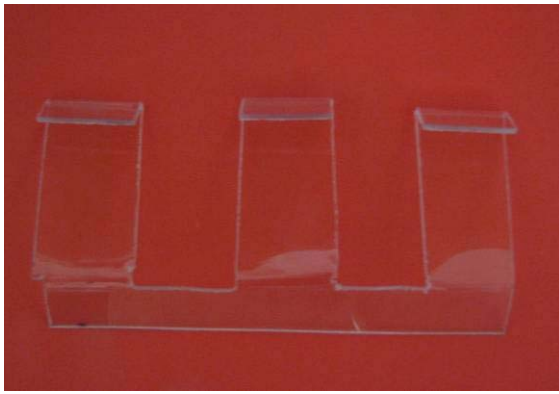

Figure 10. Latches for Tasks 1 and 2



Figure 11. Thermistor for Task 3

6. CHALLENGES

There are several challenges that the team has to face almost every year, and most of them involve being a large team and being based on an island. These two facts mean that team management is integral to the process of designing and building an ROV, and traveling internationally to compete with it. To deal with these issues, we designated several team members as 'Team Leaders' at the beginning of the designing process, and these members were responsible for collecting contact information, compiling design ideas into a folder, organizing meetings, planning the trip and obtaining materials for the building process.

A new challenge we faced this year was created when we decided to use pontoons as the basis of our chassis. This required us to find access to a CNC router to mill the pontoon shape out of Styrofoam. Then, we had to learn how to fiberglass the chassis. O'Donel High School has a CNC router, which we were able to access to cut our Styrofoam and other ROV components. Working through manufacturer's tutorials and some consultation with the high school technology teacher allowed some team members to quickly become familiar with the operation of the router. One of our Team Leaders asked a fiberglassing expert from the Marine Institute to teach us how to fiberglass. Once they learned the technique, several team members were able to fiberglass the pontoons without further external assistance. The Marine Institute also allowed us to use a boat-building workshop that had been designed to allow fiberglass work without exposing ourselves to fumes.

7. TROUBLESHOOTING TECHNIQUES

We used several troubleshooting techniques throughout the process of designing and building our ROV. One such technique was used in association with our thrusters. When we began testing our ROV, we noticed that the thrusters were not performing as well as they had in previous years. We conducted Bollard pull tests of our thrusters, which indicated that they were delivering about 35% of the 27 N thrust that they had provided in previous years. In order to define a solution, we needed to determine how and why this was occurring.

We tested the intact thrusters and discovered that they were rough and unusually noisy during operation. Disassembly of the thrusters revealed that there was no restriction when turning the drive shaft through the gear heads, but there was roughness in the motors. Disassembly of the motors revealed broken and excessively worn brushes. We tried to acquire replacement brushes from the manufacturer; however we were unsuccessful, as they do not sell replacement parts. After this, we began a search for alternatives to address the problem. The following table illustrates our results:

Table 3. Summary of alternative thruster models

Brand	Model	Cost/unit (\$)	Volts DC	Power output (W)	Thrust (N)	Torque (mNm)	Length (mm)
INUKTUN	118777	N/A	24	90	27	949	117.51
MAXON	118777	\$495.00	30	90	27	949	117.51
MinnKota	70T	\$120.00	24		311		381
Seabotix	BTD150	\$395.00	19	80	28.4		173
Zeitlauf	GK6355	\$502.63	24	95		271	196
Zeitlauf	BCI5260	\$368.48	24	55		169	160

Based on availability and price, we feel that the MinnKota thrusters are the best possible option. They would be appropriate to complete the required tasks and could be used until we complete construction of our own thrusters. They have been ordered but it is unclear if they will arrive in time to test and add to the ROV for this year's competition. If they do not arrive in time, we will use our current thrusters for this year's competition and complete construction of our own thrusters for next year

8. FUTURE IMPROVEMENTS

This has been a very productive year for Eastern Edge Robotics, and we



are very proud of the design and development of our current ROV. However, there are still some things that need to be improved, and one of the most important changes to make is to our thrusters. We are experiencing problems with the six 24 V commercial thrusters that were donated to us several years ago by Inuktun Inc. The main problems with our current thrusters are:

- i) They are worn, and need expensive repairs: Of our six thrusters, only one is fully functional, meaning that unless we can get the other thrusters functional in time, we may need to find alternative thrusters to use for the 2008 competition.
- ii) They are brushed: this causes them to have a lower power-to-weight ratio, and makes them prone to wear and electrical noise
- iii) The pulse-width modulators required to control them take up valuable space in the onboard electronics can.

We are in the process of designing and building our own thrusters, but do not think that they will be ready for the 2008 competition. We would like to make our own brushless thrusters with embedded PIC controllers. These would be more reliable, efficient and durable than our current commercial thrusters. The main benefits of the new thrusters would include:

- i) They would be brushless: this means there would be no brushes to become worn or require maintenance. It would also give them a higher power-to-weight ratio, and would cause less electrical noise
- ii) It would allow us to consider different thruster arrangements: because the thrusters would be brushless, the permanent magnets and windings could be placed in different positions relative to the prop.
- iii) They would have embedded controllers: this would allow for fewer connections to the thrusters from the electronics can, and would allow for a smaller can, as pulse-width modulators would not be needed.

Other things that we would like to improve are:

- i) A better tether management system, with hybrid fiber-optic rotary joints and an improved launch and recovery system.
- ii) Innovative ROV control, with image processing of the video feed to identify mission goals and hazards for autonomous control. We would also like to implement SONAR, force feedback (touch/vibrate on joystick), touch screen and voice activation
- iii) A seven function manipulator: a multi-purpose tool that can be used for multiple years/competitions.

9. LESSONS LEARNED/SKILLS GAINED

This years mission tasks required an innovative ROV, and our initial design ideas required us to learn several new technical skills, including:

- Programming and working with PIC controllers



- Linking and synchronizing two cameras to provide stereovision
- Terminating fiber-optic cables
- Fiberglassing to create the pontoons
- Computer aided manufacturing using artCAM software and a Techno LC Series 3024 CNC router

There were also several lessons learned in terms of teamwork. In previous years, the team was mostly comprised of engineering students. This year, our group has students in electrical, mechanical, civil, and marine engineering, computer science, computer programming, biology, biochemistry, nursing, and kinesiology. This made the brainstorming and designing processes different than previous years, because not only did we have to deal with different skill levels, but completely different academic backgrounds and problem-solving methods. To deal with this, we decided to do all of our initial brainstorming as a group. Once everyone had discussed each component of the ROV, we then focused on the individual parts of the ROV in smaller groups, which were created based on what each team member wanted to work on. This was positive for the design process, as no matter what aspect of design you were involved in, everyone contributed to the initial designs for each aspect of the ROV. This exchange of ideas was crucial for the final development, and led to some of the most innovative features of this year's ROV, including the use of PIC controllers and the development of stereovision. We plan to implement this group brainstorming strategy into our team meetings in future years.

10. REFLECTIONS ON THE EXPERIENCE

"I have always been interested in robots, but have never had the opportunity to gain experience in the robotics field. Joining Eastern Edge Robotics this year enhanced my interest in robotics, and presented many new opportunities. One of the main things I loved about being on the team was that it gave me an opportunity to work with students outside my own field (engineering). This allowed me to see the point of view of people in different fields, and challenged me to incorporate everyone else's ideas into my own perspective. Being such a diverse team allowed us all to consider a wide range of ideas and concepts, and to understand the importance of trying new methods and designs. I loved seeing how everyone worked together on so many different components, and how so many components must be brought together to finalize the product. Overall, working with the Eastern Edge Robotics team has been a valuable experience, particularly in developing my mechanical design skills and creating opportunities for networking with industry professionals. It has been rewarding to see the teamwork and dedication of every team member, and the progress made after months of dedication."

-Nancy Hillier

“This was my third year on the Eastern Edge Robotics team, and it has been a constant challenge on my technical skills. I am a marine engineering student at the Marine Institute, so I have completed three full terms of lathe class, and have a lot of experience creating precise works on a lathe at school. This year, our ROV’s design required extensive machining, and so despite my previous experience, I still had to learn a lot about using a lathe. Some of the machining this year included creating a watertight brass connector piece for our tether, a watertight Lexan camera tube and machining propeller clearances in ABS pipe. I made custom cutting tool bits from mild steel for specific o-ring diameters. I cut fine threads in Lexan to a custom depth, allowing for an o-ring clearance within 1.27cm (1/2”). I also worked with distorted 10cm (4”) ABS pipe to make the inside diameter true to 0.38mm (15/1000”) for propeller clearances. All of these tasks were very time consuming and challenging, but this precise work greatly advanced all aspects of my technical skills.” -Mikhail Freeman

11. DESCRIPTION OF A PROJECT THAT USES ROVS TO STUDY MID-OCEAN RIDGES

ROPOS: Using Canadian Innovation to Explore the Ocean



Since the discovery of mid-ocean ridges in the 1950s and deep-sea vents in the 1970s, scientists around the world have studied these phenomena, investigating the scientific implications of their existence.¹ One way of studying ridges and vents is through ocean observatories - underwater arrays of electronic instruments designed to relay information about the ocean to scientists on land. One such observatory is VENUS (Victoria Experimental Network Under the Sea), operated by the University of Victoria, in Victoria, British Columbia, Canada. It consists of an array of instruments in three different locations around southern British Columbia. Each location has its own acoustic sensors and cameras, along with equipment to measure ocean currents, temperature, turbidity, gas content and zooplankton abundance, among other things. Each piece of underwater equipment is connected to a central node, which regulates power distribution and communicates with the surface using a cable. VENUS provides real-time data, allowing researchers and the public to log in and view current conditions at any time. All data is archived for future use, allowing scientists to reference measurements, images and sound collected from past observations.²

The data collected by VENUS is also contributed to another project: NEPTUNE (North-east Pacific Time-Series Undersea Networked Experiments.) NEPTUNE is a marine observatory related to VENUS and a similar project,



MARS (Monterey Accelerated Research System) located in Monterey Bay, California. NEPTUNE is an international project, with components based in Canada and the United States. Like VENUS, NEPTUNE Canada is operated by the University of Victoria, and both VENUS and NEPTUNE have received funding from the Canadian Foundation for Innovation and the British Columbia Knowledge Development Fund, among many other sponsors. NEPTUNE Canada plans to be the world's largest cable-linked seafloor observatory, with five or six individual nodes supporting 700 sensors around the Juan de Fuca plate, and work will soon be complete on laying 800km of cable on the northern side of the Juan de Fuca tectonic plate. NEPTUNE will have sensors similar to those used by VENUS, recording biological, chemical and geological data at each location.³

Being located in very deep water, VENUS and NEPTUNE are often serviced and maintained by ROVs, particularly by one named ROPOS, which is operated by the Canadian Scientific Submersible Facility (CSSF). The CSSF is a successful not-for-profit organization that operates on contracts with many universities, companies and governmental departments. ROPOS is an advanced underwater vehicle which has been used extensively to deploy and maintain scientific instrumentation. It has a maximum depth rating of 5000m, using six hydraulic thrusters and seven 250W HID and quartz lights to explore the depths of the ocean. ROPOS has two seven-function manipulators, and adaptable sensors for sampling equipment and navigation. For the NEPTUNE project, the ROPOS crew developed the Remotely Operated Cable Laying System (ROCLS), which can lay up to 8km of cable on the seafloor at a time, replacing the need for tedious cable deployment by surface ships.⁴

VENUS and NEPTUNE function to measure biological, chemical and physical characteristics of the ecosystem and environment around a mid-ocean ridge. Observatories such as these were the inspiration for the ROV *Pontus*. *Pontus* was designed to complete tasks such as recovering damaged equipment, collecting specimens, and reading and recording physical conditions. These tasks are essential to marine observatories that study mid-ocean ridges, and ROVs like ROPOS and *Pontus* are becoming more involved in these tasks as their capabilities advance.

References:

Photo credit: ROPOS Crew (CSSF), from <http://www.ropos.com/gallery.htm>

¹<http://www.whoi.edu/oceanus/viewArticle.do?id=2512&archives=true>

²<http://www.venus.uvic.ca/>

³<http://www.neptunecanada.ca/network/index.html>

⁴<http://www.ropos.com/>



12. ACKNOWLEDGEMENTS

We would like to extend our sincere gratitude to the following sponsors:

Dundas Data Visualization (gauge presentation software)
Eastern School District, NL, Canada (donation of facilities)
Faculty of Engineering, Memorial University (financial assistance)
Imprint Specialty Promotions (donation of polo shirts)
Inuktun Inc. (donation of thrusters)
Leoni Elocab (custom-built tether)
MATE (for providing this opportunity)
Marine Institute, Memorial University (financial assistance and use of facilities)
O'Donel High School (use of facilities and equipment)
Focal Technologies (Moog) (donation of multiplexer for fiber-optics)
Ultragraphics (donation of t-shirts)

To our parents, families and friends, for their support and encouragement

And a special thanks to our mentors: Clar Button, Tom Donovan, Dwight Howse and Diane Howse, for giving up so much of their time and energy.

APPENDIX A – FLOW ANALYSIS

Computational Fluid Dynamic Calculations Using FloWorks

A fluid dynamic calculation was conducted using FloWorks, computational fluid dynamic software created by SolidWorks. This was done to show the drag forces exerted on the ROV as it travels through water. For the purpose of this study, the coordinate system has been defined as: positive Y-coordinate to be below from the ROV and positive Z-coordinate to be AFT from the ROV. The positive X-coordinate is facing PORT from the centerline of the ROV. The motion of the ROV has been simulated as follows:

- 1) Surge forward at 0.5 m/s, ROV exclusively
- 2) Surge forward at 1.0 m/s, ROV exclusively
- 3) Heave up at 0.5 m/s, ROV and OBS combined
- 4) Heave up at 1.0 m/s, ROV and OBS combined

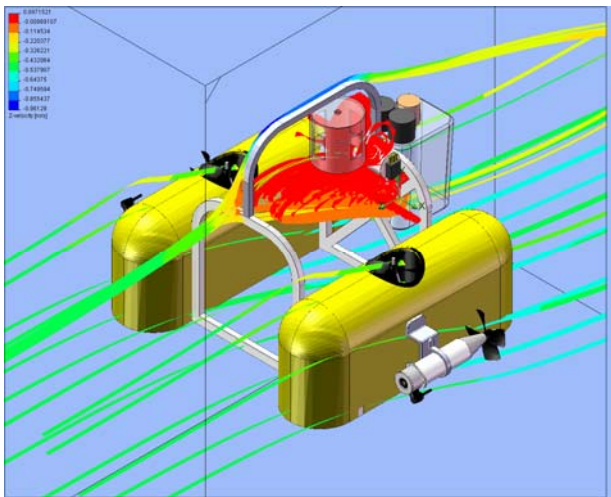

Figure A1. Flow trajectory of fluid particles as the ROV surges forward at 0.5 m/s:

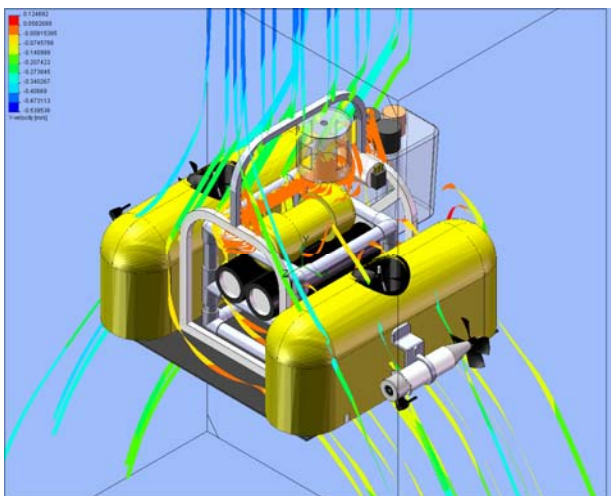

Figure A2. Flow trajectory of the fluid particles as the ROV/OBS rises at 0.5 m/s:

The following table displays the respective forces felt by the ROV:

Table A1: Forces on ROV in motion

Parameters		Drag Force [N]				Delta	Criteria
Motion	Velocity	Converged Value	Averaged	Min.	Max.		
Surge	0.5 m/s	47.55987113	46.319	44.0575	47.5599	3.5024053	0.39316922
Surge	1.0 m/s	192.71881141	192.358	191.485	192.729	1.2441316	1.52567545
Heave	0.5 m/s	63.68415008	63.134	60.8379	67.0313	6.1934788	6.23110035
Heave	1.0 m/s	247.00620916	258.68	271.109	247.006	24.102579	24.9260357

The drag force is in the opposite direction to their respective motion, e.g.: surge forward (negative Z-direction) at velocity of 0.5 m/s exerts a force of 46.3 N in the positive Z-direction. As shown by the values obtained from the simulated fluid dynamic computation, as the velocity doubles the drag forces exerted on the ROV quadruples.

Drag Coefficient Calculations:

The force on a moving object due to a fluid as defined by the drag equation is:

$$F_d = \frac{1}{2} \rho V^2 C_d A$$

Where:

F_d is the force of drag [N]

ρ is the density of the fluid [kg/m^3]

V is the velocity of the object relative to the fluid [m/s]

A is the reference area, which is the cross sectional area perpendicular to the direction of motion [m^2]

C_d is the drag coefficient [non-dimensional]

Rearranged for drag coefficient:

$$C_d = \frac{F_d}{\frac{1}{2} \rho V^2 A}$$

The density of water will be assumed to be 998.19 kg/m^3 , and the reference areas to be approximated as follows:

Front:

$A = \text{Width} \times \text{Height}$

$A = (0.584\text{m})(0.305\text{m})$

$A = 0.178 \text{ m}^2$

Top:

$A = \text{Width} \times \text{Length}$

$A = (0.584\text{m})(0.542\text{m})$

$A = 0.317 \text{ m}^2$

Surge at 0.5 m/s: $C_d = 2.09$

Heave at 0.5 m/s: $C_d = 1.60$

APPENDIX B – ELECTRICAL SCHEMATICS

TOPSIDES MODULE

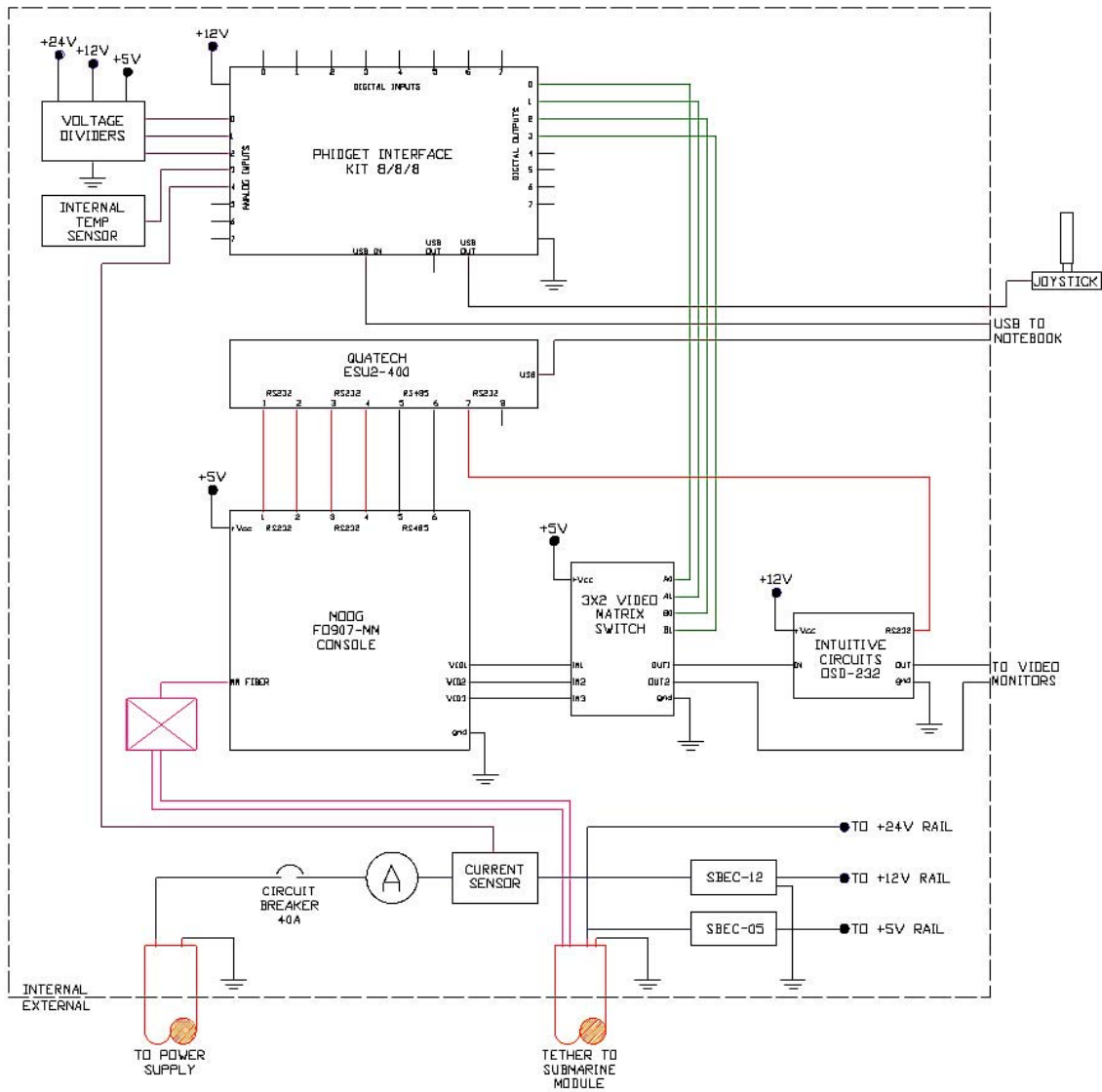

Figure B1. Schematic for topsides electronics

SUBMARINE MODULE

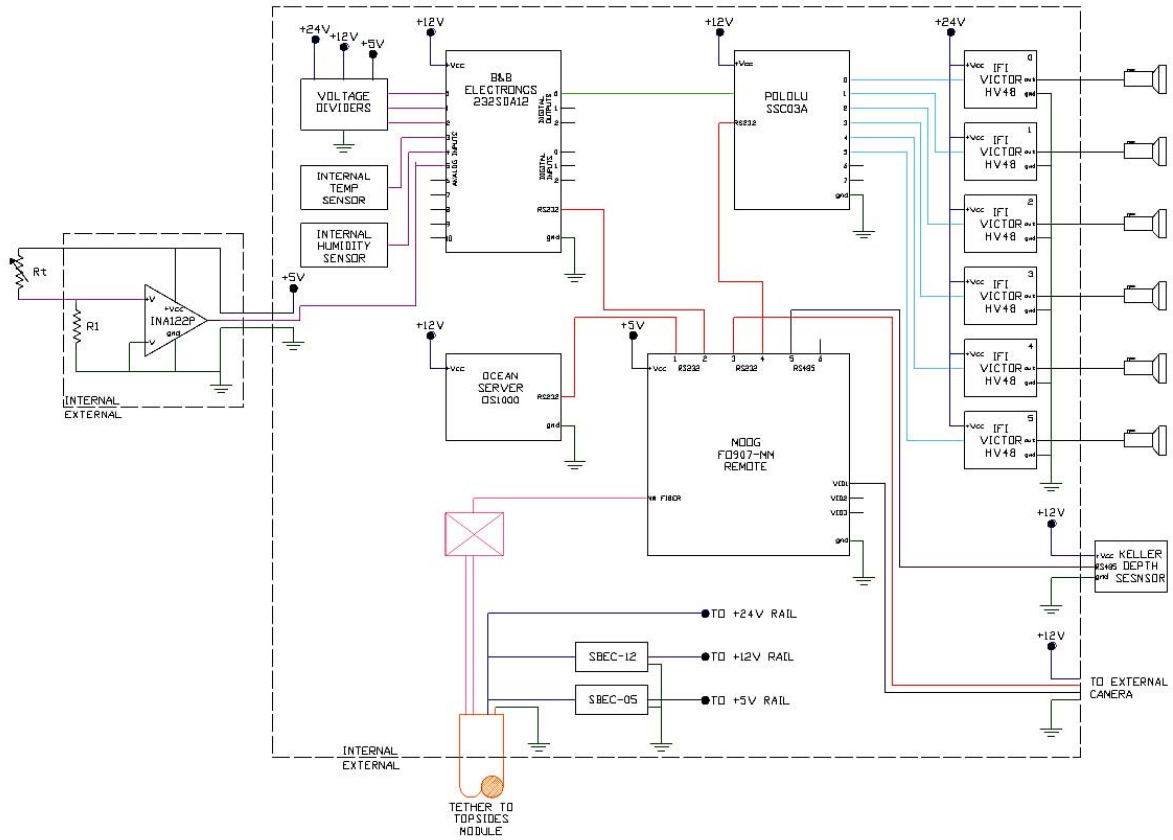

Figure B2. Schematic for submarine electronics

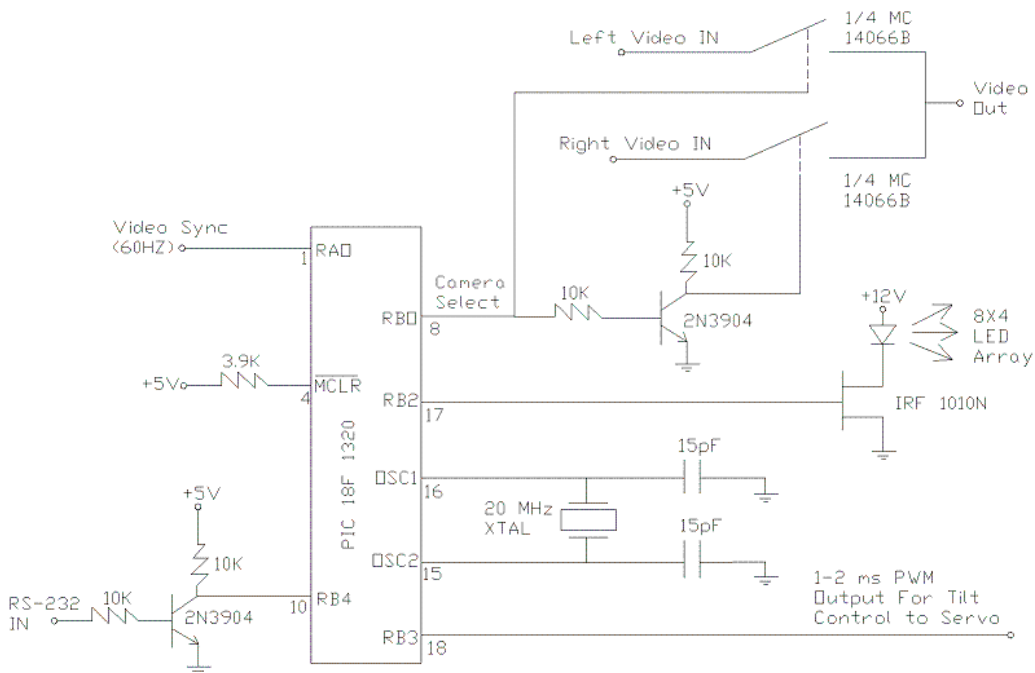

Figure B3. Electronic schematic for stereo camera