

Technical Report

Heritage Robotics

featuring ROV Sobek
Ranger Class



Team

Gavin Diamond
Mark Dooley
Michael Holloway
Brandon Howse
Danielle Howse
Andrew Maillet

Jade Moss
Suyen Oldford
Brandon Peddle
Devin Russell
Christy Smart
Jonathan Young

Mentor: Mr. Michael Spurrell



Table of Contents

Abstract	3
Introduction	4
Mission Overview	5
Vehicle Systems	6
Design Rationale	6
Introduction	6
Frame	7
Propulsion	7
Buoyancy	8
Sensors	8
Electronics	10
Payload Description: How we did it	11
Budget	13
Trouble Shooting	13
Future Improvements	15
Lessons Learned	15
Challenge	16
The Deep Frontier	17
Reflections	18
Acknowledgments	20
References	21
Appendix	22

Abstract

Heritage Robotics is very proud to present the following technical report which communicates the details of *Sobek*, a Remotely Operated Vehicle (ROV), created by students from Heritage Collegiate, Lethbridge, Newfoundland and Labrador, Canada. The group has dedicated countless hours to designing and constructing a ROV that could efficiently complete the mission assigned for the 2008 Marine Advanced Technology Education ROV contest.

MATE's seventh annual competition is being hosted at Scripps Institution of Oceanography and the University of California, San Diego. This competition focuses on hydrothermal vents found at mid-ocean ridges and the technologies used to study these deep-sea environments. There are three tasks outlined for the Ranger class, each providing its own challenge. *Sobek* was designed to successfully carry out these tasks with precision and accuracy.

This document includes: detailed descriptions and diagrams of *Sobek* and its components; the challenges we overcame; the lessons we learned; possible future improvements; reflections; a thorough budget and expense explanation; information on the expedition Extreme 2004: Exploring the Deep Frontier; and acknowledgements of all those who helped along the way.

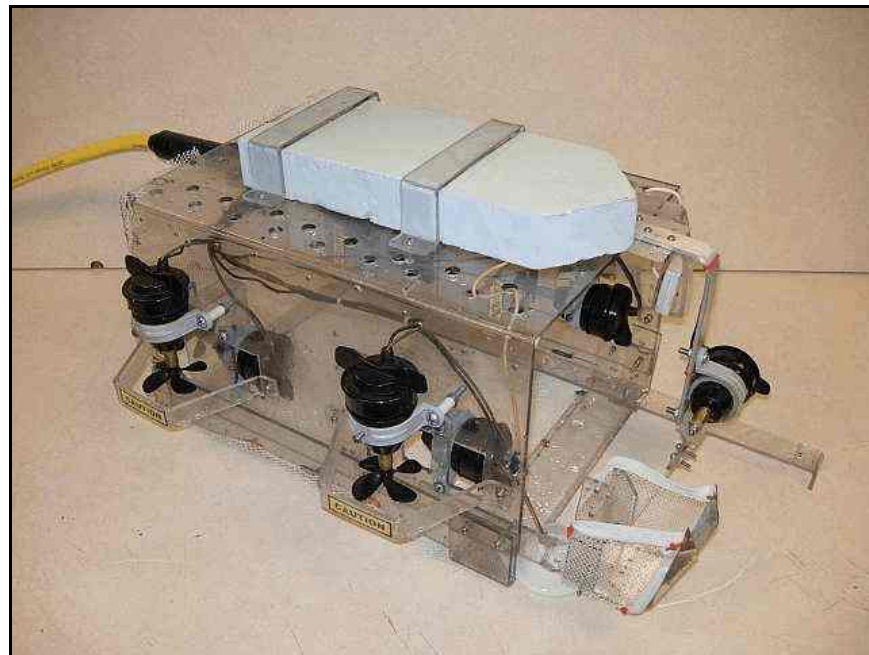

ROV - Sobek

Introduction

This fall, a group of twelve students and one teacher mentor from Heritage Collegiate, Lethbridge, Newfoundland and Labrador, Canada, convened with the hope of competing in the MATE International ROV Competition. There were many ideas to consider and obstacles to overcome, but finally we completed our masterpiece.

The primary objective of this project was to build a remotely operated vehicle that could successfully complete a number of set tasks. Due to the diversity of these tasks, our ROV had to be strategically designed. This required the creation of a rigid frame, useful end effectors, and a versatile propulsion system. A form of buoyancy, effective sensors, and proper wiring were also necessary. Ultimately, it was a difficult engineering task.

The team spent numerous hours researching, planning, building, and field testing our ROV. We had to be ready to combat technical problems and overcome the challenge of differing opinions. Through research of expeditions such as Extreme 2004: Exploring the Deep Frontier, we gained insight into the complexity of constructing an ROV capable of completing the mission.

We are very proud of our accomplishments and are confident that *Sobek* will lead us to success.



Mission Overview

Task #1: Collect up to three vent crabs.

This task is modelled to simulate catching vent crabs (Figure 1.) on a mid-oceanic ridge. Vent crabs are mobile organisms that may scurry and/or hide to avoid capture, which makes them difficult to catch. The main objective of the ROV in task #1 is to collect three model vent crabs (bodies made of one and one-half inch ABS end caps and legs made of 30cm long brown pipe cleaners, which are each about 1N negatively buoyant) on the sea floor and then transport them to the surface.



Figure 1. Vent Crab

Task #2: Collect up to three samples of a black smoker.

In 1977, scientists made a stunning discovery on the bottom of the Pacific Ocean that forever changed our understanding of planet Earth and the life that inhabits it. They found sea-floor vents emitting warm, shimmering, mineral-rich fluids into the depths of the ocean. To their surprise, the vents were gleaming with extraordinary, unexpected life. These hydrothermal vents release extremely hot water, recorded at temperatures up to 403°C, and are filled with chemicals. When this water comes in contact with sea water, it creates the infamous “black smoker.” The main objective of the ROV in task #2 is to collect three samples of the black smoker (Figure 2.) and bring them to the surface.



Figure 2. Black Smoker

Task #3: Measure the temperature of hydrothermal vent fluid.

Hydrothermal vents are found along the ridges of the sea-floor where the plates that make up the Earth’s crust are spreading apart or being pushed together. Temperatures at these sites can reach 403°C. As previously mentioned, fluid from the vents (Figure 3.) is full of minerals and chemicals which include iron, copper, and zinc sulfides.

In this task, the main objective is to locate the hydrothermal vent, insert a temperature sensor into the venting fluid, and obtain an accurate reading which will be displayed on the ROV’s video monitor. When the ROV receives a reading, it must be reported to the control shack before moving on to any other task, or returning to the surface.



Figure 3. Venting Fluid

Vehicle Systems

Throughout the entire process, the team focused on two main goals: simplicity, and originality. The team felt that building parts that were simple, yet effective would reduce the chance of failure and increase the chances for success. Some examples would be the controller and buoyancy. (Appendix A.) Far more complex methods may have been used, but the team decided on simplicity. There were also many original ideas. One of our original design innovations included creating our frame out of lexan, and molding it with a heat bender. Another creative design that allowed *Sobek*



Figure 4. Devin Manufacturing



Figure 5. Propeller and Shaft



Figure 6. High-density Foam

to be driven more easily was the shape of its controller. The controller was made out of lexan and was molded to fit the pilot's hands. The control outlay, which contains two-way momentary switches, was created using unique concepts and allows the pilot to access the controls with ease. An original concept that allowed our ROV's safety to be maximized was hand-molding lexan into square propeller guards. Propeller hubs were made from custom machined cylindrical brass stock (Figure 5.). The buoyancy was cut from high density styrofoam, a common building material used by bridge engineers (Figure 6.). The end effectors for our robot were created from simple, original parts such as pieces of lexan that were bent to perfection or tin pieces assembled to create a gathering space for our rocks.

Design Rationale

A design was required that would allow the ROV to travel and maneuver easily, while performing the assigned tasks. There were six main components which were planned in great detail: frame design, propulsion, end effector design and placement, buoyancy, sensors, and electronics. Each separate component had to interlock completely with the other five to produce a functional design.



One of our many brainstorming sessions

Frame

The first component considered was the frame design. A specific type of body was needed to satisfy several requirements. The frame (Figure 7.) had to be rigid, stable, allow attachment of end effectors, and have little drag. After many hours of design and problem solving, the group decided that an open-ended box shape would satisfy each of the requirements and allow easy access to the ROV's internal components for maintenance and troubleshooting. Seven millimeter Lexan was chosen as the building material since it is strong and sturdy, but can easily be bent and molded with the application of heat. As well, the team drilled multiple holes in the top of the frame to allow water to flow through easily and in turn increase the rate at which the robot could dive and surface.

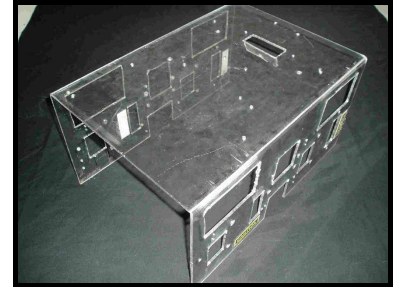

Figure 7. The ROV Frame

Propulsion

The propulsion was modeled after an ocean liner's podded propulsor (Figure 8.). The motors (Figure 9.) are taken from 5000L/h Johnson bilge pumps. The group simply had to remove the bilge pump housing (Figure 10.), attach propellers to the ends of the prop shafts, and then attach these shafts to the motors. Each motor exerts a force of approximately 7.0N and draws 1.3A of current out of water and 2.8 A in water. A bollard test was used to determine this information (Appendix B). To attach these motors to the ROV, each motor was first placed inside a short piece of 3cm inch PVC pipe. This pipe was then glued to a plastic bracket and the set screw was tightened to ensure that the motor would not shift. The motors were then attached to the ROV by placing a bolt through each of the two holes on the bracket and attaching them to the frame.



Figure 8. Podded Propulsor

The group decided to use four vertical motors to create sufficient lifting force and speed. These were distributed throughout the ROV in such a way that there are two motors on either side of the ROV. This causes the ROV's center of gravity to be at the structural center. Furthermore, four horizontal motors were used to allow the ROV to move swiftly and accurately in water with increased maneuverability. These were positioned at each of the ROV's inside corners to provide balance and stability.



Figure 9. Bilge Pump Motor

The propellers on the ROV consist of four plastic blades and are 70mm in overall diameter. When the propellor rotates, the circle created measures 70mm in diameter. The pitch is 35mm. This means the ROV moves forward 35mm for every one full rotation of the propeller.



Figure 10. Bilge Pump

The propellers were chosen based on several important factors including: diameter, pitch, weight, price, and availability. To test how they would affect the overall mission performance, a series of investigations and a bollard test were performed. Furthermore, the diameter of the propeller blade had to exceed that of the motor in order to produce sufficient thrust. The pitch of the blade, which depends on the diameter and the rotational speed of the motor, was also an issue. The propellers were selected to provide considerable thrust without drawing too much current. The rake (the degree the blades slant forward or backward in relation to the hub) is 20 degrees and the ROV has a 5mm female brass insert head. The propellers are lightweight and thin, which are the optimum type for higher speed applications, and enable our ROV to complete its mission more quickly and efficiently.



Figure 11. Propeller and Shaft

To attach the propellers to the bilge pump motors, a shaft (Figure 11) was machined from brass rod. The shaft consists of a 5mm male brass head and attaches securely to the motor using a brass set screw. Brass was used to avoid both rust and corrosion of the shaft.

Buoyancy

Our goal when designing the buoyancy system was to make *Sobek* neutrally buoyant and stable under water, while using the simplest method possible. We had considered using a ballast system of air and a compressor but determined a much simpler method would be better. To accomplish this, the buoyancy was completely constructed using high-density Styrofoam. To keep water resistance to a minimum, the foam was cut into a rectangle shape and trimmed to a point on one end. This Styrofoam was chosen because it compresses very little at a deep depth (a lower density Styrofoam would compress and cause the ROV to lose its buoyancy and sink). The size of the Styrofoam was determined using a method of trial and error. We knew the ROV was neutrally buoyant when it did not float to the top or sink to the bottom. We customized this material and helped increase the speed of our ROV by making simple original changes. These changes include pointing our buoyancy in the front to allow *Sobek* to flow through the water much faster.

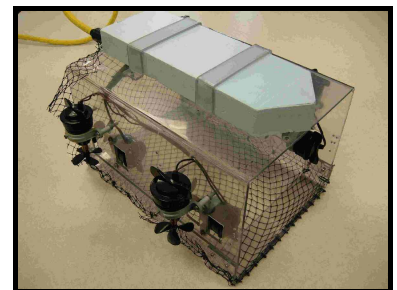

Figure 12. Buoyancy atop the ROV

Sensors

There were three sensors used on the ROV; two devices for measuring temperature, and a camera used for video. The first sensor used for measuring temperature was fabricated from a digital cooking thermometer (Figure 13.). The thermometer was coated in hot glue and wrapped in plastic for waterproofing. It contains an LCD screen powered by two AA batteries, and has a stainless steel probe secured with a bracket molded from lexan. The thermometer was placed on the side of the ROV to ensure it did not obstruct the camera's view, but was still easily read.

The second thermometer is the Taylor Precision 3512 pocket thermometer made of stainless steel and a plastic watertight lens. This thermometer is a backup in case we have electronic difficulties with the primary thermometer. This thermometer measures from 0-220 degrees Fahrenheit. It is placed opposite the digital thermometer, in the bottom right corner of the camera's view.



Figure 13. Digital Thermometer



Figure 14. Pocket Thermometer



Figure 15. LCA7700C

The final sensor on our ROV is the underwater camera used for navigation. *Sobek's* camera (Figure 15.) is the model LCA7700C supplied by *Lights Camera Action*. It has a highly sensitive colour module that requires only 0.0001 Lux (the amount of visible light per square inch meter incident on a surface). It is equipped with 6 built in infra-red LED's and IR-sensitive colour reproduction. The LCA7700C has a horizontal resolution of 380 TV lines, an imager with 1.8cm color CCD, a picture element of 290,000 pixels, and a video output of 1V p-p obm composites. A 12V DC power source with a tolerance of 9-15V is required to operate the LCA7700C. It uses a 3.6mm (92 degree) lens and has a depth of 33 meters. We used this camera because of its amazing quality and user-friendly features. It has a wide angle, it is light-weight, and it has a complete waterproof design. It also exhibits a live and vivid picture quality with built-in video enhancing technology, and has been specifically designed for ROV use.

After choosing the camera, the next task was to determine where to mount it on the ROV. It is strategically placed near the back of the ROV so that no obstructions impair the vision of the camera. It is angled slightly downwards to provide the driver with a maximum viewing area, as well as a better view of the payload tools and the area slightly below the ROV.

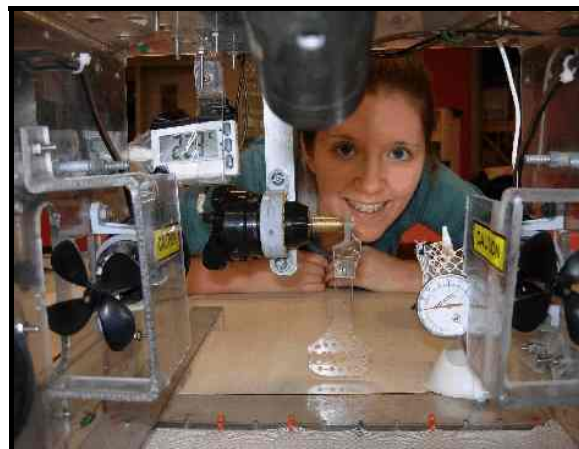

The view from Sobek's Camera

Electronics

An important aspect of any ROV is the electronic system. An ROV requires electronics to operate its motors, receive input from sensors, and send control signals. It was critical that our electrical system be efficient and designed to be used safely in water.

- Controller

The electronic navigation controller (Figure 16.) is constructed of three two-way momentary switches to control the horizontal and vertical thrusters, and one two-way momentary switch which operates the rotational collecting device. The controller is made of transparent lexan and is designed to fit the pilot's hand. This allows multiple switches to be used with ease. This design was preferable to variable controls because it is very reliable and low maintenance. The design was tested and found to allow the precision control necessary for the movement of the ROV.

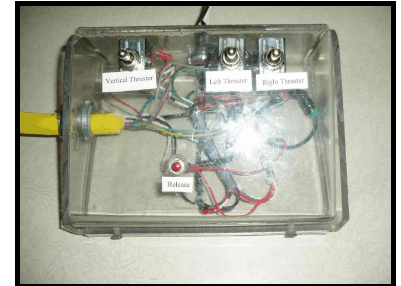

Figure 16. Navigation/Electronic Controller

- Tether

The tether (Appendix C) used on our ROV contains nine wires, one of which is a coaxial cable used for the camera, while the other eight are used for the payload tools and powering motors. It measures 11.27m in length and is neutrally buoyant. Neutral buoyancy is achieved through a filler in the tether which eliminates air and causes the tether to be of the same net density as water. The tether also has a polyurethane coating that protects its managers from electric shock.



Figure 17. Tether

- Fuse

A primary safety feature in the ROV's electrical system is the inline fuse (Figure 17.). A fuse is a small safety device which causes an electrical circuit to stop working if the electric current becomes too high, thus preventing fire or other perils. The fuse is placed between the control box and positive terminal on the battery. If a power surge or short circuit occurs, the thin metal filament in the fuse will burn out, stopping all electrical current. This will prevent the wires and electronic systems on the ROV from overheating and causing damage. The fuse can carry a maximum of 25A prior to breaking the circuit.

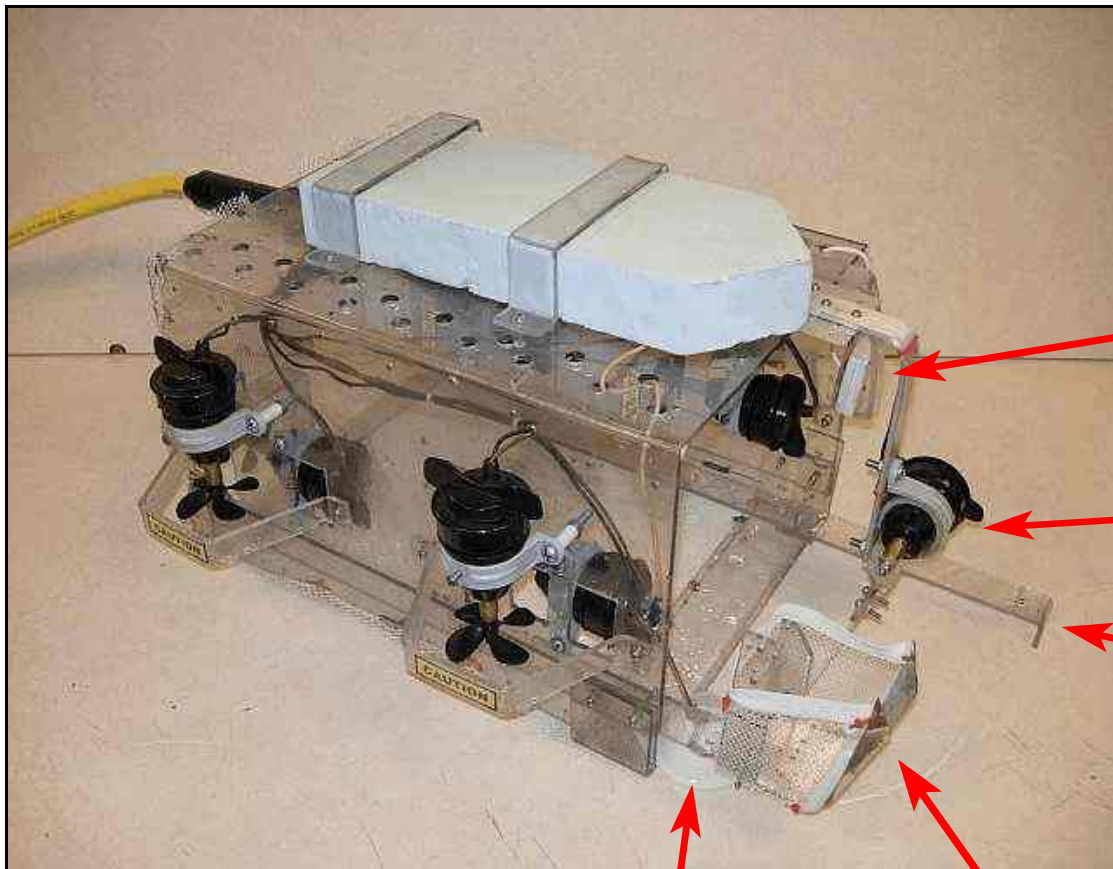

Figure 17. 20 Amp Fuse

Payload Descriptions: How we did it

End Effectors

The most critical part of our ROV are the end effectors. Without these tools, the ROV would be unable to perform any actions other than motion. It is very important that these tools are effective, but also simple in design and function. A simpler tool that works as well as a complicated tool is less likely to break, and is easier to repair or replace.



Temperature Display

Rotational Collecting Device

Specimen Retriever

Temperature Probe

Sample Collector

ROV - Sobek

Task #1: Measure the Temperature of the Hydrothermal Vent Fluid.

To complete the task of taking the temperature of the smoker, we decided to use a funnel and a thermometer placed on the lower right side of the ROV, in the camera's field of view. This location allows the ROV to easily position itself over the Thermal Vent. The funnel, placed around the temperature probe, directs the water so that the thermometers do not have to be positioned as precisely. This allows to quickly measure the temperature while over the smoker. We are then able to see temperature readings using the camera which is focussed on the thermometer screen. A second mechanical temperature probe was attached to the ROV as a backup to allow verification of the temperature reading.

Task #2: Collect Three Vent Crabs.

This task requires the use of two separate payload tools. First, a specimen retriever, made from an elongated piece of lexan with a hook on its end, is used to extract crabs from tiny cracks and crevices. This tool is located on the lower left side of the ROV and in the camera's field of view. Second, a rotational collecting device was constructed from a shovel-shaped section of thin plastic and attached to a 5000 L/h bilge pump motor. Upon locating a crab, the motor rotates and the shovel directs the specimen into the body of the ROV. The plastic contains multiple tiny holes to decrease resistance and increase the speed of rotation. This tool is located at the front of the ROV and is centred in the camera's field of view. *Sobek's* frame is surrounded by a net which allows the ROV to capture the crabs and take them to the surface.

Task #3: Collect up to Three Samples of a Black Smoker.

This task requires samples to be pried from a black smoker and returned to the surface. The sample collector is made up of lexan, galvanized sheet metal, and a net. To dislodge the rocks, a sample collector was designed and modelled after the claws of a hammer. The V-shaped groove is inserted onto the underside of the sample, and applies leverage as the ROV attempts to surface. This payload tool was constructed from a section of galvanized tin to prevent corrosion. As well, to collect the samples, a net was placed directly below the payload tool. The lexan is used to make the net rigid. As each sample is removed, it slides down the claw and into the collection net. This mechanism is located on the right hand side of the camera's field of view.

Budget

After much strategic planning and deliberation over finances, our project stayed on budget (Appendix D). Since this was the team’s third year of competition, many of the materials and tools needed had already been purchased. Nonetheless, there were some additional materials required. To cover the costs of the materials and extras, the team had to depend on student resources, fund-raising, and donations. Each student was involved in a variety of fund-raisers which included everything from selling tickets to sweeping parking-lots. Various organizations donated money and resources to our project, including a large test tank which was built and donated to our school. Since our school is located in the rural community of Lethbridge, there were additional expenses associated with attending both the Regional and International competition. Total expenses including travel were \$21,301.09, and total income from the above mentioned resources was \$13,700.00.



Sweeping Decker’s Parking Lot

Trouble Shooting

The Technique

There is always potential to encounter challenges when constructing and testing an ROV. To overcome these challenges, a nine-step problem solving process (Figure 18.) was used. First, the team had to identify the problem and develop a design brief to determine the limitations. Second, we had to conduct research (Figure 19.) and brain-storm (Figure 20.) to generate possible solutions. Third, the team decided on the optimal solution through consideration of all advantages and disadvantages. Finally, a prototype (Figure 21.) was constructed and repeatedly evaluated to test its efficiency. If this solution proved to be inadequate, the process was repeated for redesign and improvement.

Nine-step Problem Solving Process

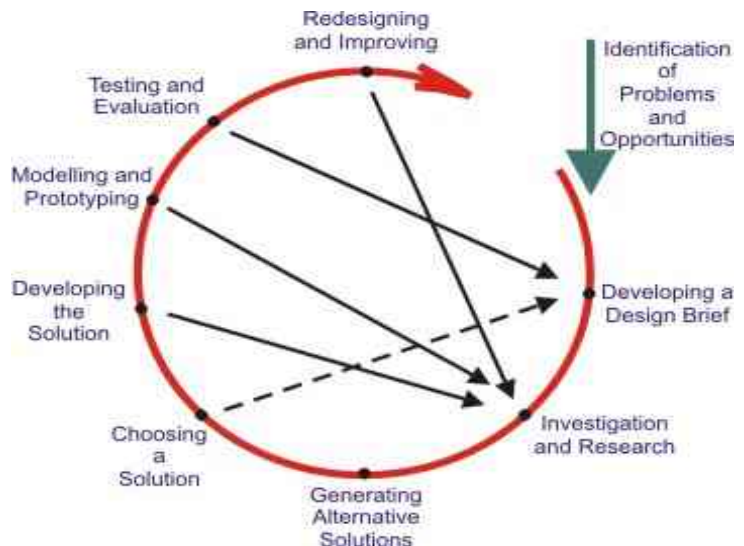

Sample Problems and Solutions

When constructing the ROV, the team encountered a number of problems which could have had catastrophic results. One of these problems involved specimen retrieval. We experienced difficulty getting the samples off the black smoker. Often the samples required a substantial amount of force to be dislodged. To solve the problem, the team reshaped the specimen retriever to resemble the claws of a hammer. This allowed the pilot the option of using the tools as a lever to pry off the samples as opposed to using direct force.

While practicing the mission, we encountered another problem. We could not determine how to get the crabs inside the robot. Finally, we decided to modify a spare thruster and attach a flat piece of plastic as opposed to a propellor. When the ‘flap’ rotated, it would propel the crab into the interior of the ROV. However, when tested, we found that it was moving very slowly. We solved this problem by drilling small holes into the rotational collecting device to increase the arm’s speed while in the water. The crabs could then be delivered into the ROV with relative ease.

During the testing of our ROV, another problem arose when collecting the first crab. When a crab was pushed into the ROV, its legs got caught in the propellers. We brainstormed once more and devised a solution to the problem; we enlarged the propeller guards inside the ROV.



Figure 19. Hours of research

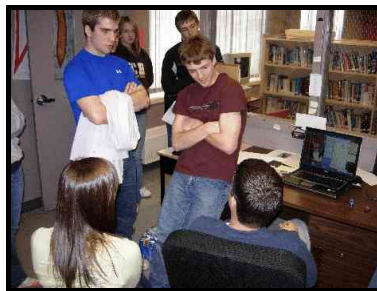

Figure 20. Brainstorming Session

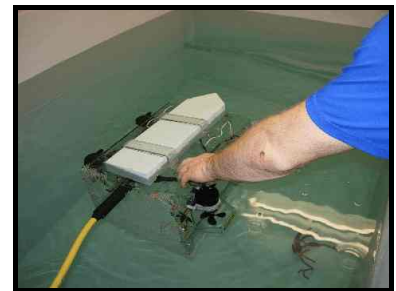

Figure 21. Testing Prototypes

While testing *Sobek* in water, we came across another setback: each time the thermometer was placed in water, it stopped working. The team brain stormed ideas that might help us obtain the temperature without destroying the thermometer. After much consideration, we found a solution. We put the thermometer in a plastic bag and wrapped it in tape to prevent the water from getting inside the thermometer.

Future Improvements

Overall, our ROV has been quite successful. It has exceptional driving capability and effective tools. One aspect of the design that might be improved in the future is the top, underside surface of the ROV. It is wide and flat with only a few holes. Therefore, it weakens the ROV's capability of diving and surfacing as quickly as we would like. To improve this, our team could build a v-shaped strip out of lexan and attach it underside of the flat top surface. To help reduce drag, two large oval-shaped holes could then be cut out of the flat surface on either end of the v-shaped strip so that water could pass through smoothly. When the robot dives, the water would be diverted away from the flat surface and the ROV would cut smoothly through the water. Another v-shaped strip could be placed on top of the ROV to work much the same, but it would allow for the reduction of drag when the robot surfaces. This would drastically increase the robot's success rate because it could maneuver much more quickly and precisely without much water accumulating on the big, bulky flat surface.



Michael tests buoyancy and drag

Lessons Learned

Throughout the project, countless valuable lessons have been learned. One of the most important was learning to work together as a unified group. We were able to help one another by making suggestions for improvements, acting as sounding boards for ideas, and making ourselves useful as the situation required. However, we also learned the value of working independently and the importance of trusting our own instincts. Consequently, we have experienced the value of practice and patience with ourselves and with our teammates.

We have also learned to appreciate the value of investing time and effort in the design and planning stages of our project. These stages ensure the consideration of the practical aspects and minimize the amount of time and materials wasted. It also helped us to develop valuable problem-solving skills that accompany this stage of the project.

The construction phase of our project allowed us to gain a wealth of beneficial knowledge including the use of a number of power tools. We have developed practical skills in how to use these tools safely and efficiently. We have come to appreciate the benefits and utility of the safety equipment we were required to use, such as safety goggles and gloves. This knowledge will benefit us throughout our lives.

Another useful skill acquired while working on our Remotely Operated Vehicle was mastering public speaking. We have used this as a confidence building experience and will continue to develop it in the future as we go through subsequent stages of the competition.

Challenge

A complex process such as building an ROV brings about many challenges. After the designing and building of the ROV was completed, our team was ready for the Regional Competition. We assumed that all major challenges had been dealt with. However, similar to real-life missions, the topography of the ocean floor should never be taken for granted. At the Regional Competition, our team expected the pool bottom to be flat. However, when we arrived to watch the first team attempt the mission, we were surprised to see that this was not the case. The bottom had been covered by a black sheet which was loosely attached. This immediately became a concern for our team, and especially our pilot. We had been practising and troubleshooting in our practice tank with a flat bottom.

The speed and accuracy of our ROV has been a great asset, but the cloth at the bottom of the tank was definitely going to slow us down. We built a rotating collection device to retrieve the crabs on the floor. In our practice tank, this was a very quick and reliable method. However, at the Regional Competition, the rotating device continued to get tangled in the loose cloth.

In an attempt to overcome this challenge, our pilot tried to flatten out the cloth before retrieving the crabs. The lightweight material, however, proceeded to float around the bottom, preventing us from using our speed and accuracy. We completed the mission as planned, but it took much longer than we originally expected.

This particular challenge was a lesson in reality for the team. While we had been prepared for ideal conditions, the unpredictability of the presence of the cloth at the bottom of the tank forced us to adapt our strategy to achieve the desired outcome.



The topography at the Regional Competition



Extreme 2004: Exploring the Deep Frontier

On November 30, 2004, Craig Cary, a marine scientist from the University of Delaware, and an international research team, began a 21-day expedition to explore one of the most demanding environments on the planet: hydrothermal vents. Extreme 2004: Exploring the Deep Frontier commenced in the waters of Manzanillo, Mexico, aboard the research vessel *Atlantis*. With the use of the submersible explorer, *Alvin*, scientists worked to learn more about hydrothermal vents along the East Pacific Rise, 2 000 kilometers west of Costa Rica. The principle aim of the expedition was to collect samples for a "metagenome project" and to gain a better understanding of how an exotic worm takes advantage of the microscopic organisms on its back to endure repeated blasts of scalding water. The metagenome sequence could be used to show all possible genes encoded by these bacteria, and which genes are actually crucial to surviving the vent environment. In addition to collecting samples, the researchers encountered a new vent site loaded with exotic Pompeii worms. Scientists who recently returned from this deep-ocean expedition concluded that they are a step closer to understanding how life thrives around cracks spewing scalding water at the bottom of the ocean.



Submersible Alvin

Making Parallels Between Alvin and Sobek

Much like our own Remotely-Operated Vehicle, the deep-sea submersible vehicle *Alvin* is equipped with tools including video cameras, a temperature probe, and claw-like manipulators that are used to collect underwater specimens, such as crabs and rocks. Our ROV has netting placed around its frame to help contain collected objects. This feature is much like the basket mounted at the front of *Alvin*, which is used to hold tools and scientific equipment, as well as to collect samples. Both underwater vehicles include cameras found on the exterior of the frame to record and view life at the bottom of the sea. Unlike our ROV, *Alvin* uses lights to illuminate the bottom. The major difference between the two vehicles is the fact that *Alvin* is internally controlled, while *Sobek* requires a tether to facilitate operation of the ROV.

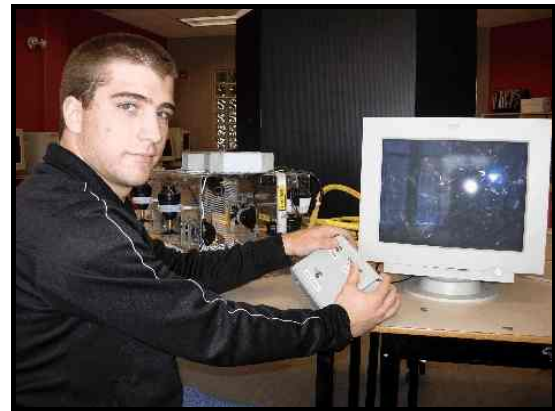
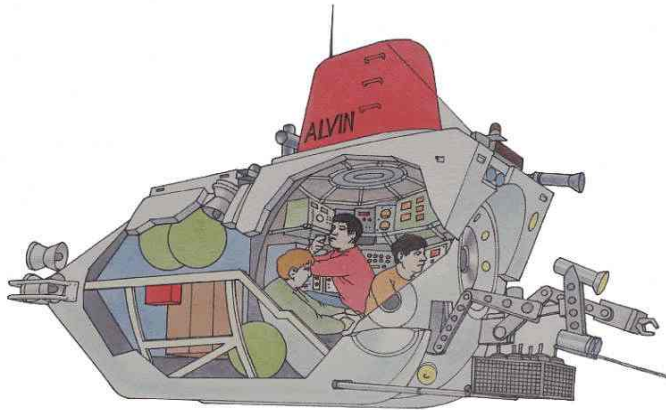

Andrew, the pilot of Sobek

Reflections: Most Rewarding Experience

An experience is defined as knowledge gained by actually doing or living through something. Completing this project was a rewarding experience for all team members involved. Relentless hours of work and tireless effort contributed toward making this project a great success. Each task and meeting has been no less than rewarding and there was, a certain feeling created by building an ROV that was truly gratifying. As a team, we had the privilege to live, work, and feel like real engineers. The planning, perfecting, determination, and pressure all contributed toward making this extraordinary experience. The knowledge obtained from creating this ROV has been endless. Something was learned with each and every completed task. It gave us the feeling of a real life scenario: We had to get it done, and we had to get it right. The way we pulled together as a team ensured the workload was spread out evenly, and our ROV was constructed with utmost care and consideration. For this reason, the feeling of teamwork is definitely the most rewarding experience we could have desired.

Personal Reflections

Christy Smart - Being on the robotics team has been an enjoyable experience and allowed me to explore my different interests. This experience will stay with me forever.

Brandon Howse - Besides being around friends, robotics has taught me responsibility. Things may hit rough patches and be frustrating, but everything is or will be rewarding in the end.

Suyen Oldford - Being a member of Heritage Robotics has been an extremely rewarding experience. It has allowed me to apply knowledge learned in school and has opened the door to new career opportunities.

Brandon Peddle - Being on the Heritage Robotics team has not only been a fun experience but a learning one as well. Now I can use my new knowledge to pursue a career in underwater robotics.

Danielle Howse - Being on the Heritage Robotics team has been a once in a lifetime opportunity for me. Many people my age will never get the chance to build an ROV that can complete assigned missions. This is something that I will never forget!

Mark Dooley - The experience of being a part of this robotics team has been nothing less than spectacular. The intensity of competition and thrill of participation have come together to create an excellent experience.

Gavin Diamond - Being a part of Heritage Robotics has been a very rewarding and fantastic experience for me. I learned valuable life skills during my experiences with the team. It provides great career opportunities and is definitely something I will never forget.

Devin Russell - I have enjoyed my time on the Heritage Robotics team. It has been an enriching and rewarding experience. I have learned many new skills which I will be able to use for the rest of my life.

Andrew Maillet - Being on several sports teams such as basketball, soccer, and volleyball have been rewarding, but in my opinion, Robotics tops them all.

Michael Holloway - Being on the Heritage Robotics team has been a great experience. I learned to solve problems both as an individual and as part of a team. I also met new people. This will not be something I will forget any time soon.

Johnny Young - Being a member of this team has been a rewarding experience for me. Not only did I spend time with friends, I've been taught to juggle responsibilities.

Jade Moss - Robotics has opened up a whole new world to me. I now see a career path in Underwater ROVs. This has been such a rewarding experience.

Acknowledgments

Heritage Robotics would like to thank our team mentor, Mr. Michael Spurrell. Without his knowledge, wise advice, and encouragement, we could not have built the ROV we have today. We would like to thank our parents/guardians for their tremendous support through finances and transportation. Also, thank-you to our school teachers who dedicated their time and assistance to help make this possible.

In addition to the support given by our school and parents, a sincere thank-you to all the companies and organizations (listed below) who have provided us with assistance and financial support.



References

- Button, Clar. Building Your ROV A Manual for High School. Avalon Robotics, 2004
- Eastern Edge Robotics. (2006) Principles and pedagogy, Retrieved May 22, 2007 from <http://www.nsac.ns.ca/cde/staff/lcj/development/prototype/glossary.htm#kirkpatrick>
- MATE. (2008) ROV Competition Page 2008, Retrieved March 10, 2008 from http://www.marinetech.org/rov_competition/index.php
- Smart Draw. (2006) Download Link, Retrieved May 12, 2008 from <http://www.smartdraw.com/downloads/index.htm>
- Exploring the Deep Frontier. (2004) “Dive Mission”, Retrieved March 26, 2008 <http://www.ocean.udel.edu/extreme2004/index.html>
- National Geographic News. (2005) “Hot-Water Worms May Use Bacteria as Shield”, Retrieved March 26, 2008 from http://news.nationalgeographic.com/news/2005/01/0117_050117_tubeworms_2.html

Appendix A: Hardware Only Approach

To reduce the possibility of error and time trouble shooting, we selected a hardware only approach.

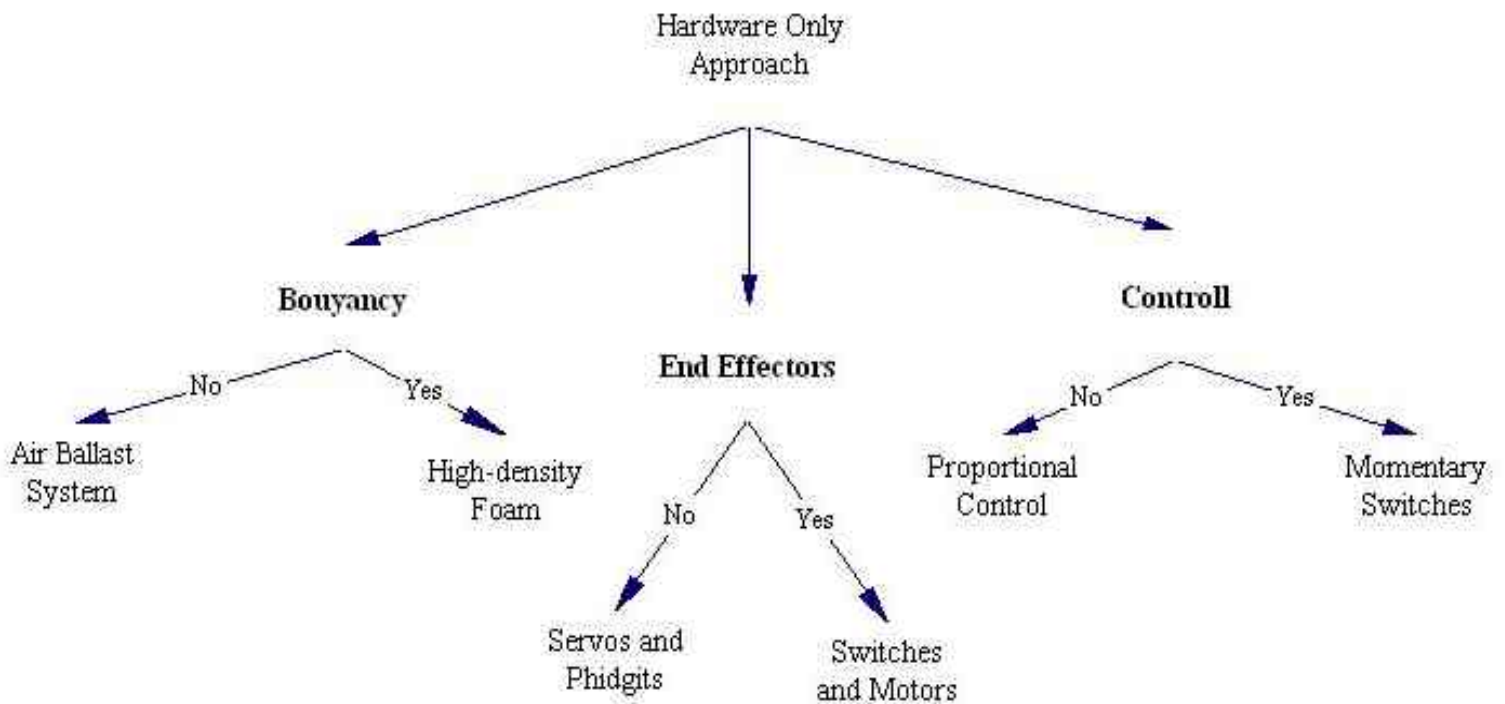

Appendix B: Bollard Test

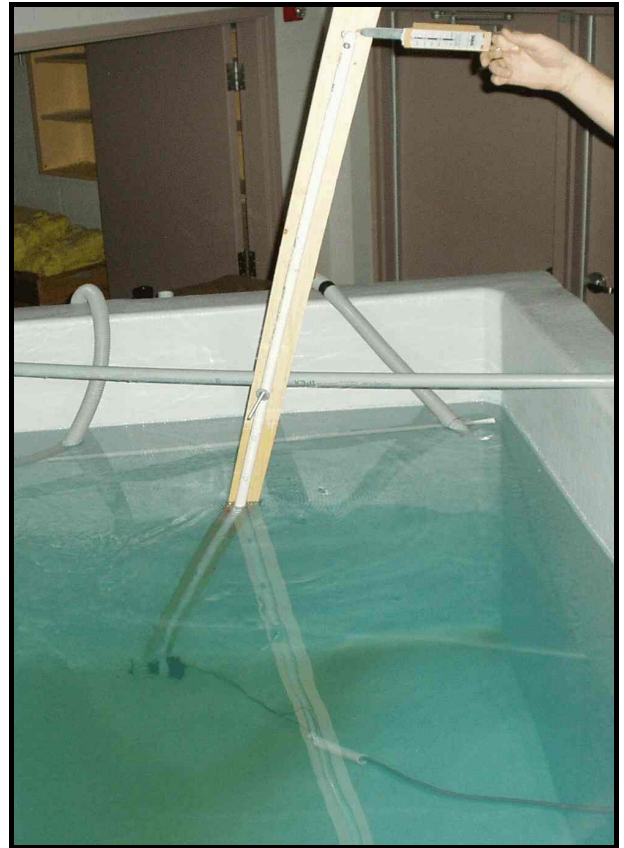
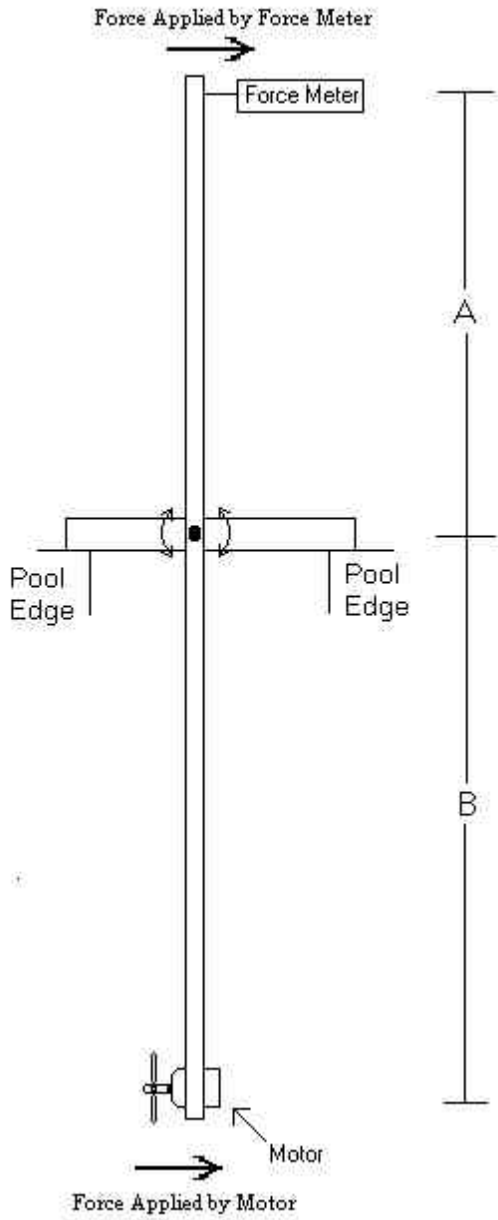

Figure 1: Bollard Test Apparatus

Table 1. Motor Force

	A (m)	B (m)	Forward Force First Trial (N)	Forward Force Second Trial (N)	Backward Force First Trial (N)	Backward Force Second Trial (N)
Test 1	1	1	7	8	2.5	2
Test 2	0.9	1.1	8	8.5	2.5	2.5
Test 3	0.8	1.2	8.5	9	3.5	3.5
Test 4	0.7	1.3	12.5	12.5	4.5	4

Average Forward Thrust = 6.7 N

Average Reverse Thrust = 2.4 N

Table 2. Current Through Motor

	Forward Out of Water (A)	Reverse Out of Water (A)	Forward In Water (A)	Reverse In Water (A)
Test 1	1.4	1.5	2.9	2.5
Test 2	1.25	1.3	2.8	2.4
Test 3	1.4	1.3	5.8	2.2
Test 4	1.3	1.4	2.7	2.5

Average Submerged Forward Current = 2.8 A
Average Forward Current (Not Submerged) = 1.3 AAverage Submerged Reverse Current = 2.4 A
Average Rev. Current (Not Submerged) = 1.4 A**Sample Calculation:**

F: force applied by motor
M: force applied by force meter
T: torque

$$T = M \cdot A \quad \text{and also} \quad T = F \cdot B$$

Therefore,

$$M \cdot A = F \cdot B$$

$$(8.5\text{N})(0.9\text{m}) = F \cdot (1.1\text{m})$$

$$(8.5\text{N})(0.9\text{m}) / (1.1\text{m}) = F$$

$$F = 6.95 \text{ N}$$

Appendix C: Electric Schematic

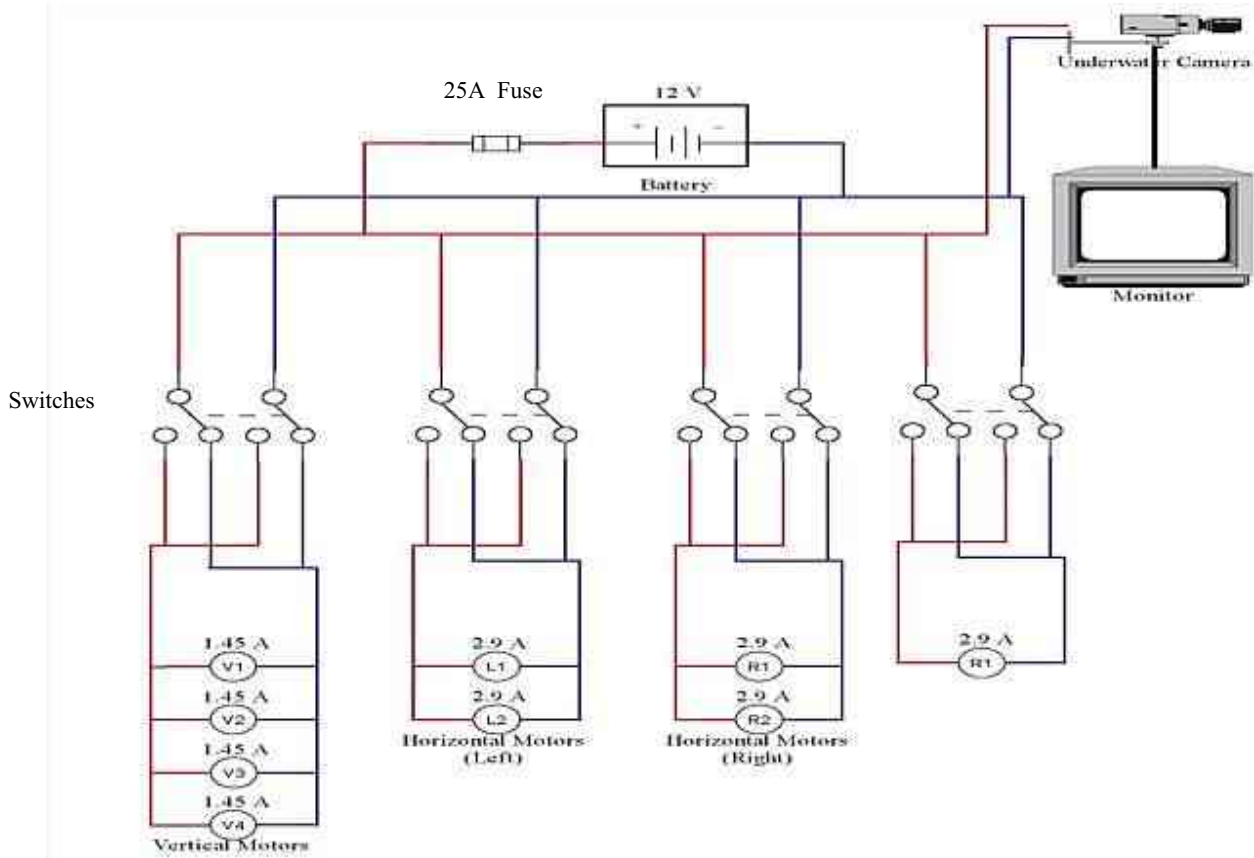

Figure 1. Schematic

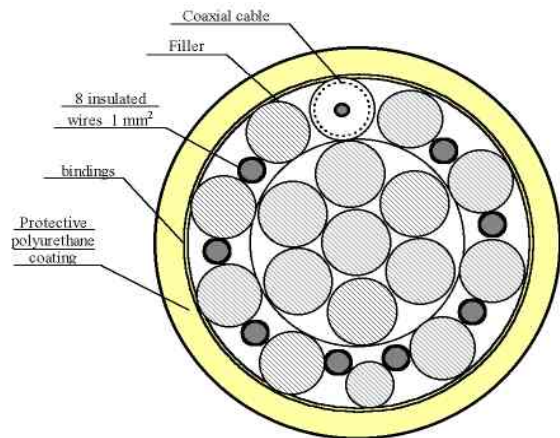

Figure 2. Tether cross-section view

Appendix D: Budget 2008

Team Name: Heritage Robotics	Budget/Expense Sheet	Mentor: Michael Spurrell
------------------------------	-----------------------------	--------------------------

Description	Unit Price	Quantity	Cost	Balance
Bolts	\$0.50	26	\$13.00	\$13.00
Electrical Tape	\$0.62	1	\$0.62	\$13.62
Epoxy	\$11.69	1	\$11.69	\$25.24
Glue	\$0.10	1	\$0.10	\$25.34
Nails	\$0.04	100	\$4.00	\$29.34
Nuts	\$0.05	32	\$1.80	\$31.14
1/4inch Screws	\$0.05	16	\$0.80	\$31.94
1/8 inch Screws	\$0.04	11	\$0.44	\$32.38
Zip Ties	\$0.04	6	\$0.24	\$32.62
Batteries	Salvaged	1	-	\$32.62
Cameras	\$210.00	2	\$420.00	\$452.62
20 AMP Fuse	\$7.00	1	\$7.00	\$459.62
Lexan	\$200.00	1	\$200.00	\$659.62
Lock Tight	\$7.50	1	\$7.50	\$667.12
Motors	\$17.00	8	\$136.00	\$803.12
Propellers	\$11.00	8	\$88.00	\$891.12
Styrofoam	\$195.00	1	\$195.00	\$1086.12
Switches	\$12.99	4	\$51.96	\$1138.08
Tether	\$106.38	1	\$106.38	\$1244.46
Strip Heater	\$259.00	1	\$259.00	\$1503.46
Airfare	\$811.92	14	\$11366.88	12870.34
Meals	\$30 per day	14	\$2520.00	15390.34
Housing	\$169.00 + tax.	14 rooms	\$5910.75	21301.09

Income

Description	Amount	Balance
Fund-raised	\$2700.00	\$2700.00
Sponsors	\$11000.00	\$13700.00
		\$13700.00

Total Balance: \$ -7601.09

Appendix E: Team Division

To solve the mission, the team was organized into several divisions as indicated.

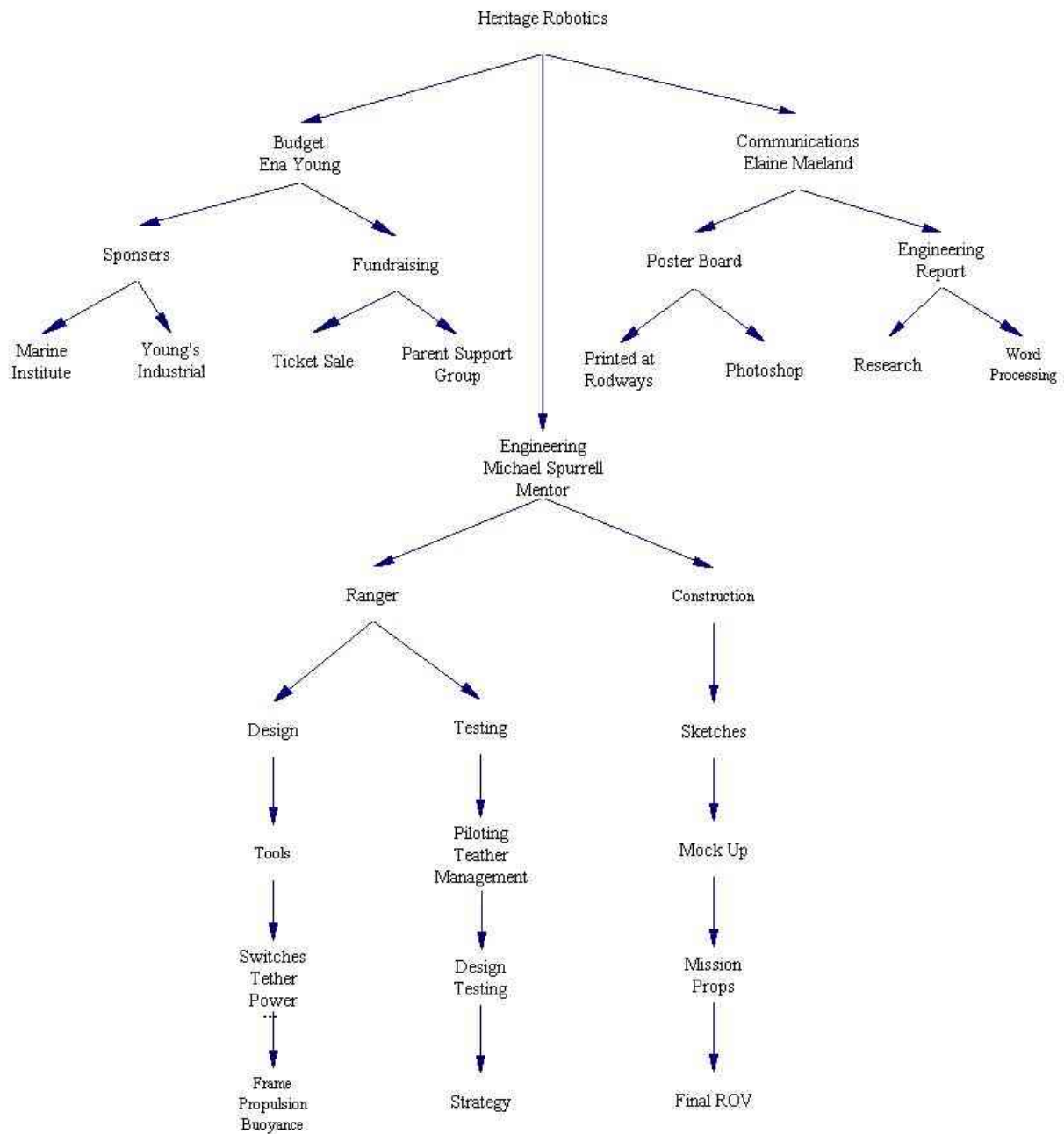

Appendix Working Hours Time Chart

Specified Task	04	08	12	16	20	24	28	32	36	40	44	48	52	56	60	64	68	72	76	80	84	88	92	96	100
Investigation and Research	█	█	█	█	█	█	█																		
Comprehending Problem	█	█	█																						
Technical Manuals/ Text Books	█																								
Emailing	█																								
Web Browsing	█	█																							
Design and Planning	█	█	█	█	█	█	█	█	█	█	█	█	█	█	█	█	█	█	█	█	█	█	█	█	█
Planning	█	█	█	█	█	█	█	█	█	█															
Structural Diagrams	█	█	█	█																					
Obtaining Materials	█	█																							
Ordering Materials	█																								
Development of Final Product	█	█	█	█	█	█	█	█	█	█	█	█	█	█	█	█	█	█	█	█	█	█	█	█	█
Construction of:																									
R.O.V.	█	█	█	█	█	█	█	█	█	█	█	█	█	█	█										
Poster Board	█	█	█	█	█	█																			
Engineering Presentation	█	█	█																						
Replica Mission Task Units	█	█																							
Testing of:																									
Motors	X																								
Buoyancy	█																								
Payload Tools	█	█	█																						
R.O.V. Performance	█	█	█																						
Post Competition Modifications	█	█	█	█	█	█	█	█	█	█															
Motor Placement	█	█																							
Structural Work	█	█	█																						
Poster Board and Presentation	█	█	█	█	█																				

(X = Less Than 4 Hours)

← Approximate Time in Hours →