

Ping! 7 MHz of Adrenaline!

Presents the

LHS Dramiscus

Lincoln High School
Portland, Oregon

Kaori Bigler • Jacob Bubalo • Leada Fuller • Chris Matteri • Erich Merrill • Henry Phipps • Katya Raffensperger • Sayer Rippey • Quinn Rohlf • Matthew Skatch • Evan Sprecher

Coach: Bart Millar Thanks to: Doug Hall, Alexandra Boyd, Joe Taylor, Neal Pisenti

Table of Contents

Abstract.....	3
The Team	4
Design of the LHS Dramiscus	6
Design Rationale	8
Safety	10
Future Improvements	10
Expenses	11
Real-World Applications	12
Works Cited.....	12
Challenge.....	13
Troubleshooting Technique	14
Lessons Learned.....	14
Reflections	15
Acknowledgments.....	17
Appendices.....	18
Appendix A: ROV Specifications.....	18
Appendix B: Programming Flow Chart.....	19
Appendix C: Electrical Schematic.....	20
Appendix D: Joystick Control	21

Abstract

Our goal for this project was to create an ROV capable of performing all of the required tasks in the simplest manner possible. A strategy that we have applied to our past three FIRST (For Inspiration and Recognition of Science and Technology) competitions with success, this influenced many of our design choices. We started work on the ROV in early November, slowly working toward the objective of a simple and elegant solution for all of the mission requirements. Because this competition was our team's first time building an underwater ROV, we encountered many new challenges which are present in the underwater environment. All of the electronics are located on the surface, making them far easier to maintain and modify. The vehicle is relatively large to facilitate alterations and allow for additional attachments. We use a three joystick system to control our ROV with a basic tank drive interface for our two main thrusters and the third joystick controlling depth. We use buttons on the joysticks for the control of functions like boost mode and lateral movement. The programming for the ROV was adapted from the code we used for previous projects with extensive changes made to the drive code and functions added to regulate depth, power consumption, and sensitivity. We began with an initial budget of \$3000 which we discovered to be excessive for this project. We obtained nearly all of our motors and flotation foam used, saving several hundred dollars and finishing with a final expenditure which was nearly \$800 below budget.

The Team



TOP (from left to right): Coach Bart Millar, Chris Matteri, Katya Raffensperger, Henry Phipps, Sayer Rippey, and Matt Skach.
BOTTOM: Erich Merrill, Quinn Rohlf, Evan Sprecher, Leada Fuller, and Jacob Bubalo. Photo by Nancy Abens

Kaori Bigler will be a junior at Lincoln next year. She has enjoyed her experience with robotics this year. She is one of the few members of the team who focus on PR work and fundraising, and we are very grateful for that.

Jacob Bubalo will be a sophomore at Lincoln next year. He loves the building aspect of Robotics and also enjoys threatening people with zip ties. He is also involved with Swim Team.

Leada Fuller will be a junior at Lincoln next year. She does the PR work for Robotics. Her weekends are often eaten by Speech and Debate tournaments.

Chris Matteri will be a senior at Lincoln next year. Chris is one of the most experimental members of the team; he always has new and interesting ideas for building. In addition to Robotics, Chris is also involved in Speech and Debate.

Erich Merrill will be a senior at Lincoln next year. He's our main programmer and although he doesn't join us for building, we would be lost without him. No one really knows what this mysterious member of the team does in his spare time...

Henry Phipps will be a senior at Lincoln next year. His favorite part of Robotics is designing and problem solving. He focuses his time and energy on the mechanical side of robotics.

Katya Raffensperger will be a junior at Lincoln next year. She was recruited to Robotics through Speech and Debate and we were very lucky to convince her to join.

Sayer Rippey will be a junior at Lincoln next year. We will never forget the generosity of her family for letting us use their pool every day after school to work on our ROV. Sayer is also involved in Speech and Debate.

Quinn Rohlf will be a sophomore at Lincoln next year. Quinn likes the mechanical part of robotics, but learned to program this year. Before Quinn joined Robotics, Erich had to do programming all by himself. Now Erich and Quinn split programming duties between themselves and work together to solve problems. Everyone knows two heads are better than one!

Matt Skach will be a senior at Lincoln next year. He took over as unofficial "Team Leader" this year and a significant part of our success came from his experience and knowledge. When he's not working on the ROV, Matt enjoys playing risk and reading sci-fi books.

Evan Sprecher will be a junior at Lincoln next year. He is one of the most persistent members of Robotics and his enthusiasm is infectious.

Team member descriptions courtesy
of Leada Fuller

Design of the LHS *Dramiscus*



Side view of ROV illustrating the layout of our thrusters



Close-up of bow decoration

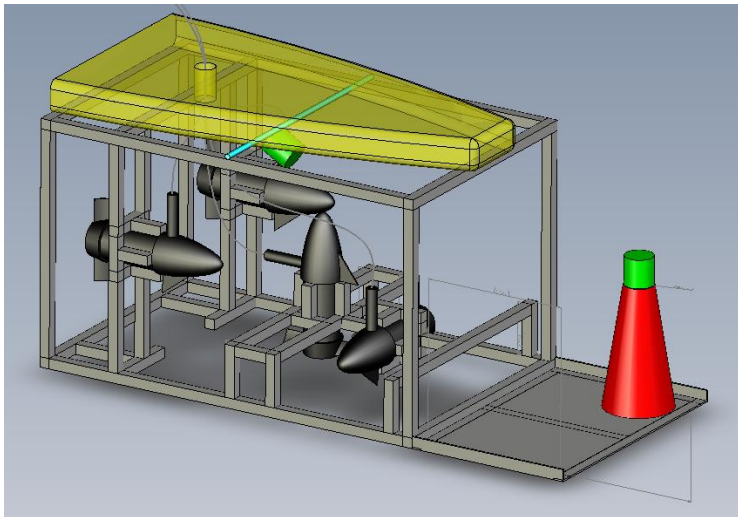

CAD image of ROV before scoop refinements

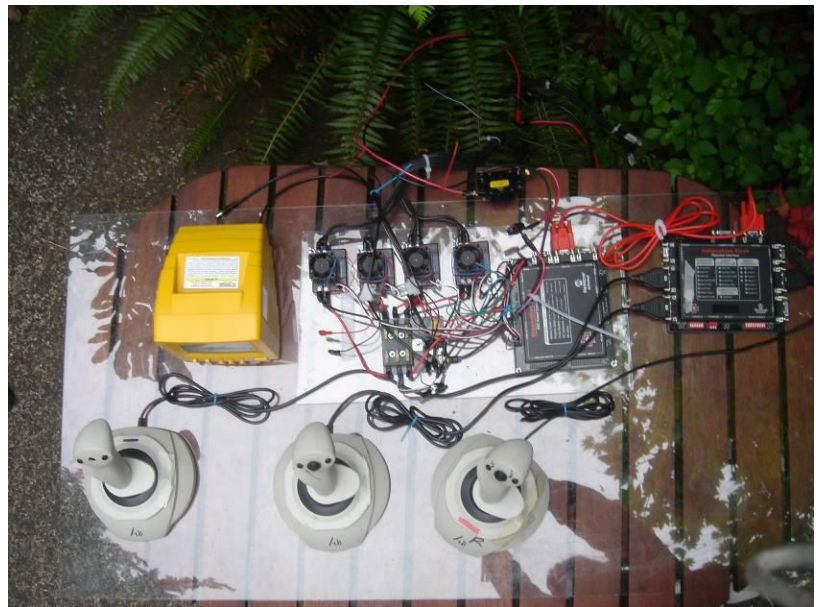

Control system layout



Close-up of front scoop

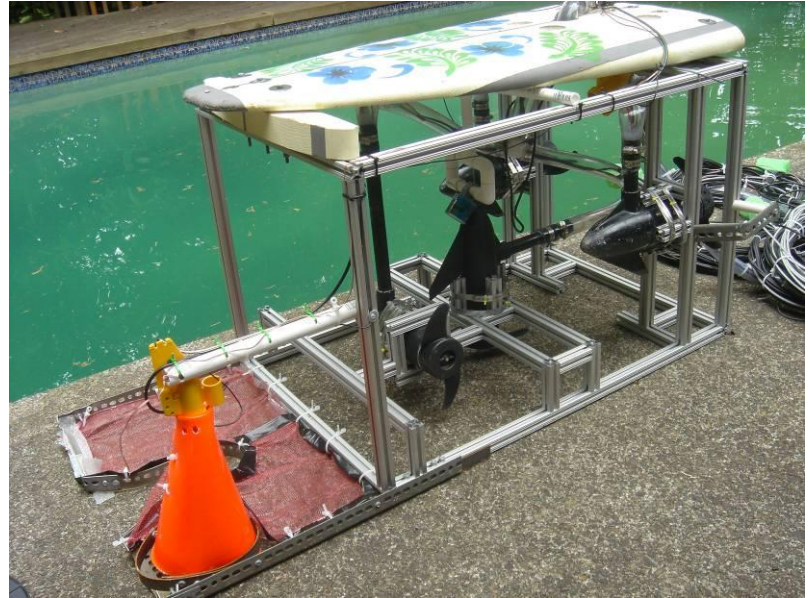

Isometric view of entire ROV

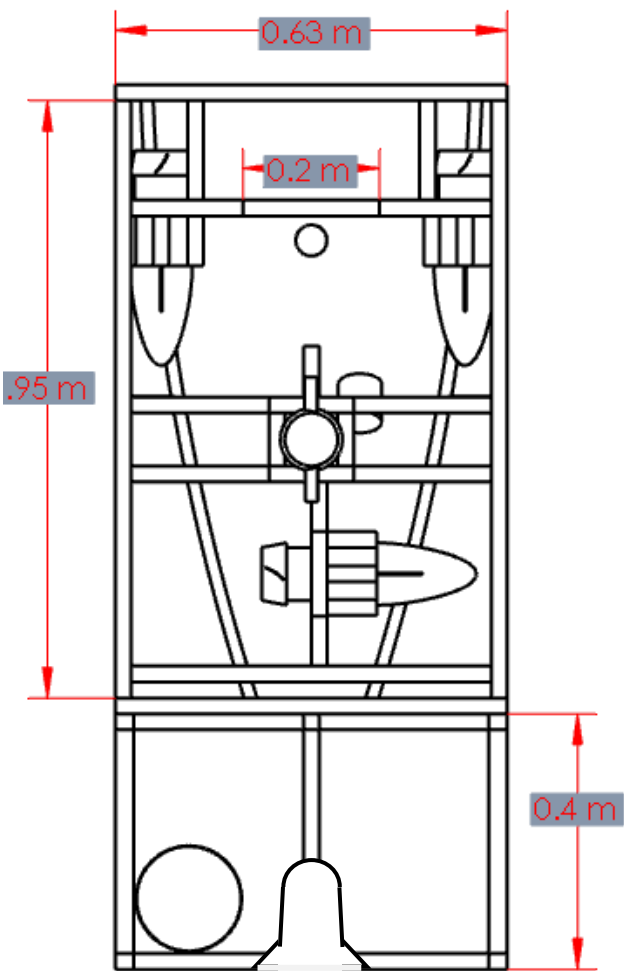

Mechanical drawing of ROV layout

Design Rationale

We designed the LHS *Dramiscus* with the overall goal of designing a simple and elegant solution to all of the tasks. The *Dramiscus* was intended to have the fewest possible malfunctions, and makes use of the simplest solutions which we came up with. Our overall objectives for this project were:

- Stay within our budget of \$3,000.
- Learn the most possible by doing our own programming, electrical wiring, and building the ROV ourselves from industry-standard materials.
- Fulfill all of the mission requirements with the simplest and most reliable equipment possible.
- Create a control system which would be responsive, intuitive, and easy to set up.

Our rationales for the Electrical, Mechanical, and Software subsystems are as follows:

1. Electrical Systems

- a. Location – We chose to keep all of our electronics on the surface in order to eliminate problems with waterproofing and make it easier for us to program and rewire the control systems. The advantages to this are that it makes maintenance much easier and facilitates modifications to the system. The trade-off was that we needed a much larger tether than if we had chosen to include onboard electronics, because of the eight heavy-duty conductors required to run the motors from poolside.
- b. Control System – We use an Innovation First operator interface and robot controller for ROV control because of our experience programming and wiring these devices. We chose to use Victor 884 speed controllers for their quick response time and compatibility with our other hardware. Currently we are developing a new control system from scratch based on a PIC microcontroller. This system will interface with our current joysticks and speed controllers, but will feature a computing unit which we built and wired ourselves, with code written by us from the bootloader up. We hope to have this system in place in time for the competition.

Figure 1: Thruster

2. Mechanical Systems –

- a. Movement – Our ROV has four Minn Kota trolling motors which we chose because they were



powerful and cost-effective thrusters which were already waterproofed off-the-shelf. They provide sufficient thrust to move our ROV very quickly, and give us a large amount of flexibility because of their wide range of available thrust. Two of these thrusters are mounted facing rearwards for easy steering and a large amount of forward power. One thruster is mounted laterally, to enable us to shift the ROV sideways. Finally, a fourth thruster is mounted vertically for depth control.

- b. Flotation – We chose to use a broken surfboard for flotation because it was extremely inexpensive and well suited to the marine environment. Bolted to the top of the frame, it caused the entire ROV to hang down from the flotation, providing the kind of stability which was needed in order to perform the mission tasks.
- c. Manipulators – None of the manipulators which we use for the mission tasks have any power or moving parts. They merely function as extensions of the ROV, which we control by moving the entire vehicle. Our large netted front design is designed to provide a highly functional multi-purpose scoop, which can hold rocks and crabs and retain them in the netting even when the ROV is at a 45° angle to the bottom. The slotted fitting in the center of the net is ideal for scraping rocks off of the simulated black smoker because it is bent to wrap around the black smoker very closely, and the entrance to the slot is flared to allow for a wide margin of error when guiding the ROV towards the smoker. For retrieving the vent crabs, a set of high intensity neodymium magnets are strategically placed along the front scoop, causing crabs to attach to the scoop by their legs or eyes. We decided that this was the best solution because it would work without our ROV needing contact with the crabs to capture them. If we approach a crab and it passes within about 2” of our magnets, we usually will capture it. Finally, we decided that rather than placing a sensor inside the vent, it would be much easier to bring the venting fluid from the vent. In order to do this we put a small traffic cone on our front scoop, which we maneuver over the vent outlet so that the venting fluid rises and comes into contact with our temperature sensors in the tip of the cone. We are currently considering a pneumatic crab retrieval device, but we have not yet determined the details.

3. Software Systems

- a. Programming – Our control system is programmed in the programming language C, using MPLAB IDE in conjunction with the Microchip C18 compiler. We chose to use these tools because we have a large amount of experience with them from 3

different FIRST competitions which our team has taken part in. We have a main drive function which includes all of our extra features and a failsafe program which is a bare bones version of the drive code, intended for troubleshooting and code failures. We are able to switch between the two by pressing a button on one of our joysticks.

- b. Interface – We drive the ROV using three joysticks, each with certain functions assigned to it. The interface was a joint effort between our programming team and our pilot, who chose every aspect of how the ROV would react to the joysticks. We use the y-axis of the left and center joysticks to control the rear thrusters, using a tank drive interface. The joystick to the right is used for control of the depth and sensitivity of the controls. For a detailed diagram of our control interface, see Appendix D.

Safety

Safety is always the number one priority for our team. We embrace FIRST's philosophy regarding safety exemplified in their FRC tournament, which is "if it's worth doing, it's worth overdoing". All potentially hazardous parts on our ROV have safety warning labels, and we have designed the ROV to be as safe as possible. Sharp edges on our frame have been filed off, we have a clearly labeled and accessible main power breaker on our control board, and we are currently creating propeller shrouds to prevent accidents with the spinning propellers. We also practice safe behavior when building. Before the ROV is powered up, we always shout out something along the lines of "CLEAR!" to ensure that no one is near the ROV. In addition, we take care not to work on the ROV while it is on in order to reduce the risk of someone accidentally bumping the controls and hurting another team member.

Future Improvements

We are very satisfied with the *Dramiscus*, but we feel that it could benefit from a few improvements in the future. One very important improvement is the addition of a camera on the top of the flotation to provide a bird's eye view of the task we are currently undergoing. Another improvement would be to use brushless motors as thrusters for increased power and efficiency. Finally, another very major improvement which we have talked about is to remake the frame of the ROV, condensing it down into a smaller package so as to be able to maneuver more effectively in small spaces.

Expenses

Item Name	Quantity	Cost Ea.	Bought	Donated	Reused
Minn Kota "Endura" Thrusters	5	\$50.00	\$250.00		
Harbor Freight B&W Video Cameras	2	\$99.00	\$198.00		
Tether Motor Cable	30.5 m	\$337.84	\$337.84		
Used Surfboard	1	\$50.00	\$50.00		
UEI Thermometer	2	\$150.00		\$300.00	
UEI Thermistor probe	4	\$25.00	\$75.00	\$25.00	
2 Conductor Speaker Wire	21.3 m	\$20.00	\$20.00		
Assorted Neodymium Magnets	7	\$1-10	\$38.00	\$6.00	
Dashboard Hula Decorations	3	\$3.95	\$15.80		
80/20 Frame	1	\$213.34	\$213.34		
Plastic Tubing	30.5 m	\$110.00	\$110.00		
Victor 884 Speed Controller	4	\$114.95			\$459.80
FRC Robot Controller	1	\$449.95			\$449.95
FRC Operator Interface	1	\$349.95			\$349.95
Assorted 80/20 Aluminum	N/A	N/A	\$91.00		
Team Logo Design	1	\$50.00	\$50.00		
Needle-Nose Pliers	1	\$10.00	\$10.00		
Meat Thermometer	1	\$29.95	\$29.95		
12-2LOWVT500	1	\$150.50	\$150.50		
Rope	30 m	\$36.00	\$36.00		
Misc. Hardware	N/A	N/A	\$69.45		
HPC PICDEM Explorer board	1	\$59.99	\$59.99		
Microchip MPLAB ICD 2	1	\$159.99	\$159.99		
Petty Cash	\$100	N/A	\$100.00		
Metal Project Box	1	\$11.19	\$11.19		
Joystick Connectors	10	\$7.80	\$78.00		
Assorted Electronics	N/A	N/A	\$54.85		
Brass Potted Thermistor Sensor	1	\$75.00		\$75.00	
Total			\$2,208.90	\$406.00	\$1,259.70

Our final expenditure was approximately \$2,200, which was almost \$800 less than our initial budget. Our most successful technique for cutting costs was to source our parts used rather than buy everything new, and also to reuse what we already had from previous projects.

Real-World Applications

ROVs are essential to underwater exploration and research because they can go places which would be dangerous to a diver without endangering human life. The Gorda Leg of the recent MBARI (Monterey Bay Aquarium Research Institute) Ridges 2005 Expedition focused on the mid-oceanic ridge known as the North Gorda Ridge. This expedition used a sophisticated ROV called the *Tiburon* (see Fig. 2). On the expedition, the *Tiburon* was used at the Seacliff hydrothermal site to collect vent biota for analysis, reflecting the situation simulated in Mission Task #1 where our ROV has to collect simulated crabs from the area surrounding a hydrothermal vent. Another parallel to our ROV is when the *Tiburon* sampled rocks from an eruption on the Northern Gorda Ridge. We collect rocks in a similar fashion during the competition using a specialized attachment to our front scoop. This expedition made wide use of the ROV for collecting samples, and obtaining data like temperature readings. This is an excellent example of how the situations our ROV is designed to handle are very similar to real-world ROV uses.

Figure 2: The *Tiburon*

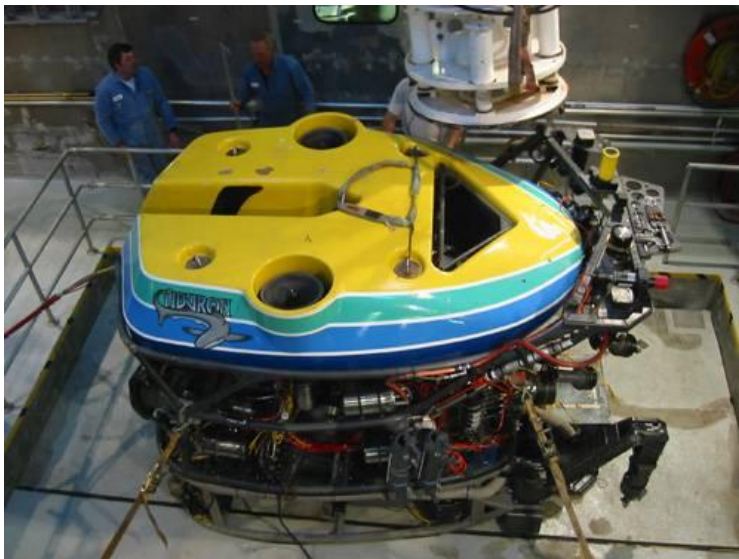

Works Cited

Clague, Dave. Gorda Ridge Cruise Logbook. 5-21 August 2002. 1 June 2008
<<http://www.mbari.org/expeditions/GordaRidge/August16.htm>>.

Hannides, Angelos K. The ROV Tiburon, MBARI. 01 August 2005. 1 June 2008
<<http://www.soest.hawaii.edu/hannides/galleries/Calbasins/Tiburon.html>>.

Monterey Bay Aquarium Research Institute. MBARI Ridges 2005 Expedition. 22 August 2005. 1 June 2008
<<http://www.mbari.org/expeditions/ridges2005/>>.

Challenge

On our ROV, the most difficult component to get functioning properly has been the temperature sensor. We began with the goal of having a digital readout in °C on our control board, accurate to within a degree. The sensor measuring temperature needed to respond quickly, given the limited time available to us. Our first device which we used for temperature was a standard meat thermometer. This gave us mediocre readings; however they were nowhere near the one degree accuracy which we wanted. Because we realized that this sensor was inadequate for the task, we acquired a system from UEI and began to work on it. This system proved to have the accuracy we needed and a very fast response time, however we were unable to waterproof the sensor, and we were having constant problems with the resistance of the extension wire we spliced in affecting the readout of the temperature. As we were short on time before the regional, the team decided to go with a very simple and effective solution. We purchased a “dishwasher safe” mechanical thermometer and placed it where the temperature dial was visible from one of our cameras. This worked very well for us at the regional for one of the rounds, but we encountered problems with the other. In order to have a more reliable system, we have ordered a new thermistor sensor from Maximum Instruments which is pre-waterproofed and calibrated for 18.5 m of cable. This sensor will plug directly into our ROV processor, which will read the resistance of the probe, calculate temperature, and output it to a laptop screen. We decided to keep the mechanical thermometer as a backup system should we encounter any problems with the new system in the future.

Troubleshooting Technique

Because we developed a great deal of our ROV through trial and error, troubleshooting was critical to our team's success. After the first few times, we developed a sequence which we used for troubleshooting any problem which didn't have an immediately obvious cause. First, we determined whether the problem was a result of hardware or software, by switching to our failsafe code. If the ROV worked with the failsafe code, we knew that it was a problem with the code, and our coding team would go and look for any recent changes which could have caused a malfunction. After debugging the code, we usually were able to fix the problem. If we determined that the problem was a hardware issue, we first checked to make sure that the whole system was set up correctly, with joysticks plugged into the correct ports and motors plugged in correctly. Then, if everything was all right, we checked all the fuses and circuit breakers which might be causing a problem. Finally, we looked at the actual components themselves which were malfunctioning. If we still didn't find anything, we repeated the process from the beginning until we were able to isolate the problem. If we couldn't come up with a solution to a problem right away, the team would have an informal brainstorming session, discussing possible alternatives. After that, we chose the best idea and began work on it.

Lessons Learned

Because we are a first year team, when we were developing our ROV not a day went by that we didn't learn something new. One of our most notable learning experiences was when we found out that silicone did not work for waterproofing. This was very unfortunate because we had used it to "waterproof" all of our connections for the temperature sensor, forcing us to rewire the whole thing. This took us quite a bit of troubleshooting before we figured out that the silicone which we had used for the connections was to blame for our problems with temperature readout. We also got to put some of the higher-level math to work in a practical setting finally, using our training in algebra to figure out an equation to model a temperature sensor's resistance in response to temperature. ($^{\circ}\text{C} = \log_{0.9601454205} \left[\frac{\text{Resistance}}{29.49} \right]$) Another thing which we learned was that we should read the rules more carefully, with the small 3m by 3m staging area where we had to maneuver at the regional competition taking us by surprise. Aside from the technical lessons which we learned, we also became better at teamwork. We now are much better at collaborating and we also communicate with each other more in order to have increased efficiency during work days.

Reflections

For our reflection, each team member was asked to contribute a small reflection on their experiences this year. These reflections are listed below:

Kaori Bigler – “It was an exhilarating experience to see the project come together from being this simple metal box to a working ROV. I can't wait for next year!”

Jacob Bubalo – “Since I joined the robotics team, I have learned a lot about electronics, such as what banana plugs are, and what H-Bridges do. I have also learned a lot about the engineering and mechanics of building with underwater in mind. I have thoroughly enjoyed building this year and hope to continue as a member of the team.”

Leada Fuller – “MATE taught me that surprising things can happen. We went into the competition as a rookie team and came out winning first place. It definitely inspired me to try new things. Working on the poster was also a great experience because of how stressful it was and how accomplished we felt when it was finished.”

Chris Matteri – “Working on the ROV has taught me that engineering is not about who can afford the most expensive designs and equipment, but instead about good, solid ideas and dedication, no matter how simple they may be. While our method of controlling the ROV, getting the temperature reading and collecting rocks and crabs was very simple, it was also very effective, which is ultimately what counts in the real world.”

Erich Merrill – “Adapting the code for our land-bot to work for our ROV was an interesting and engaging project. I'm looking forward to next year, when our microcontroller will be brand-new, opening up a whole new set of programming possibilities and challenges.”

Henry Phipps - "Building the Dramiscus has taught me things about mechanics and engineering that I not only didn't know about, but find fascinating. With this experience and knowledge it continues to help me narrow down my ideas of what my career choice might be."

Katya Raffensperger – “I joined the team this year knowing next to nothing about robotics, and have learned a lot since then. I have enjoyed finding out new things and helping to build the ROV. I am looking forward to the competition in San Diego, and to starting next year's ROV.”

Sayer Rippey – “MATE was a great experience for me, and I had fun in whatever I was doing - whether it was helping build the Dramiscus, making the poster, or supplying people with mint tea. I definitely look forward to participating next year, and helping build a similarly strange-named ROV.”

Quinn Rohlf – “I have thoroughly enjoyed working with the team on our ROV, and I learned an incredible amount about underwater mechanics and applications through building the ROV and researching for the technical report. I look forward to next year, because we seem to be improving every year.”

Matt Skach – “Building the ROV has been both challenging and rewarding. I have learned a lot about electronics and what's visible in a murky pool versus what isn't. Overall, I had a great time and plan on coming back next year.”

Evan Sprecher – “It's surprising what you can get done when you set priorities. Never play with two or more neodymium magnets.”

Bart Millar (coach) – “I am not a specialist—in programming, mechanical or electrical engineering. I am a project manager who is fortunate enough to work with intelligent, self-directed and persevering students who are mainly self-taught. My belief in the intrinsic drive of humans to learn and build is vindicated in our MATE team.”

Acknowledgments

We would like to thank the following individuals and organizations for their support of our team:

- The LHS Boosters' Club for financial contributions
- Nathan Rogol for his help procuring and assembling thrusters
- Doug Hall for his help towards the goal of a new control system
- Alexandra Boyd for her expertise in fundraising
- UEI for their generous contribution of temperature sensors
- Maximum Instruments for their donation of a thermistor probe
- The Rippey family, for allowing us to use their pool and providing us with other helpful things
- Piers Rippey, for his great paint job which can be seen on our ROV
- The MATE center, for organizing and creating the competition
- All of the volunteers who made this possible
- And finally, all of the team members' parents, without whom none of this would have been possible

Appendices

Appendix A: ROV Specifications

Our ROV uses a wide variety of commercially available parts and materials. The specifications for these items are as outlined below:

- i. ROV Frame – The ROV’s frame is constructed out of 2.54 cm T-slot 80/20 aluminum extrusion bar. (part # 1010)
- ii. Thrusters – Minn Kota “Endura” type trolling motors. Each can produce up to 30 pounds of thrust.
- iii. Tether
 - a. Motor cables – For each of the four motors there is a 30 m length of two strand ribbon cable with, each strand containing a 12 gauge multi strand insulated conductor.
 - b. Reinforcement – Also included in the tether is a 30 m span of .5 cm airline-type cable for stress reduction and emergency recovery of the ROV.
 - c. Video Cables – The tether contains 3 video cables – two for the Harbor Freight sealed cameras and one for the custom potted color camera.
- iv. Speed controllers – We use four Victor 884 speed controllers from Innovation First, driven by PWM signals
- v. Control System – Our control system is composed of an Innovation First FRC robot controller tethered to an Operator Interface, which we have used before in FIRST competitions.
- vi. Cameras – We have three cameras mounted on the ROV. Two are sealed units from Harbor Freight (91309-5VGA), and one is a custom potted camera from the MATE 2007 summer workshop. The depth rating for the harbor freight cameras is 18.5 m and we estimate the depth of the custom camera to be beyond that.
- vii. Magnets – We use a variety of Neodymium, stainless steel cased magnets for capturing vent crabs.
- viii. Flotation – A broken surfboard is used for flotation. This has closed-cell foam, ideal for underwater applications.
- ix. Alternate Control system – We are working with the HPC Picdem Explorer board, which contains a PIC18F8722 microcontroller. We are programming this to work with all of our existing hardware, as a replacement to the FIRST Black-Box style controller we currently have.

Appendix B: Programming Flow Chart

The program which we use for our ROV is called approximately 13 times a second, looping continuously until power-off. We have a very complex control interface, using all but two of the buttons on our joysticks and all of the triggers. See Appendix D for joystick information.

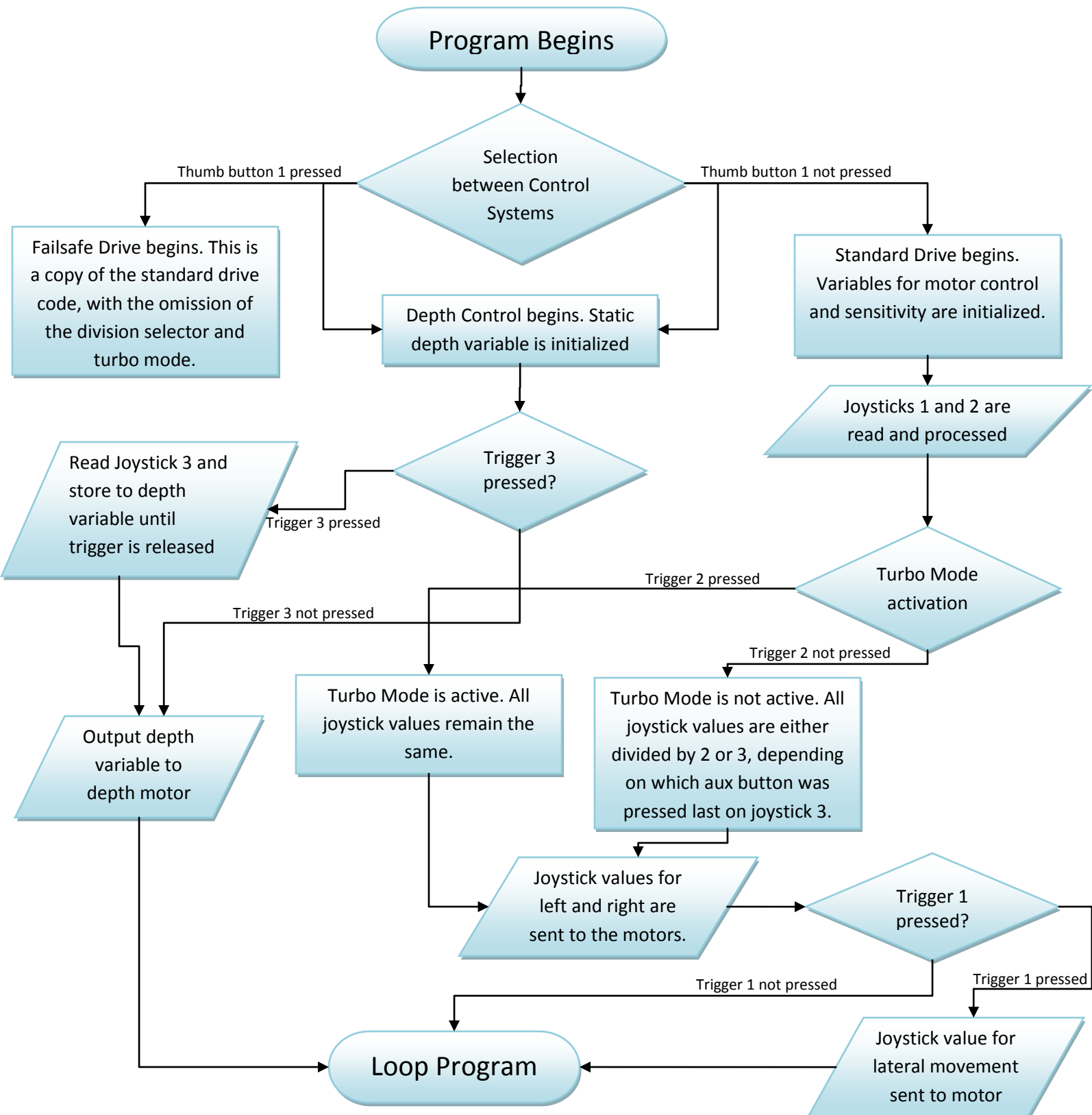

Appendix C: Electrical Schematic

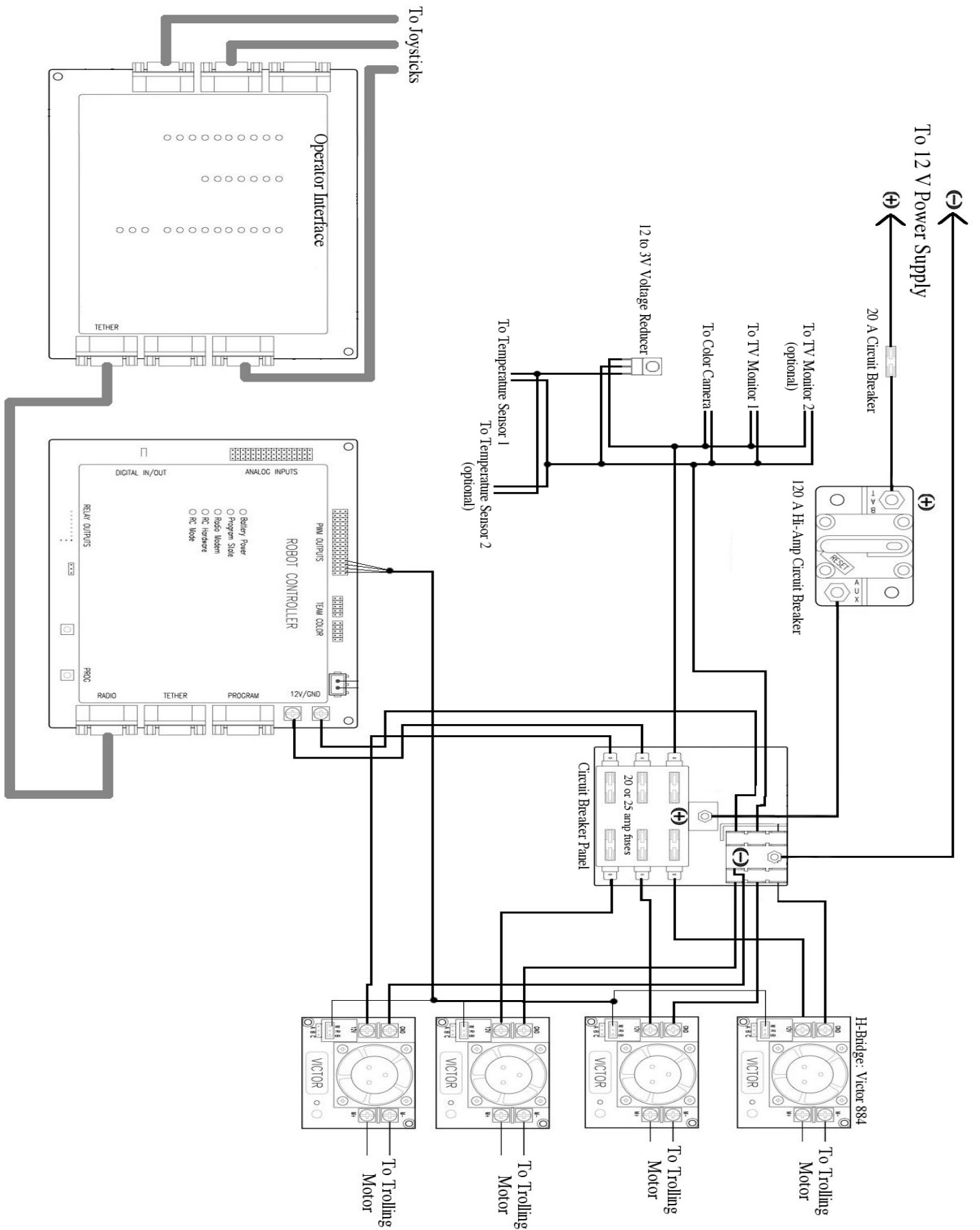

Appendix D: Joystick Control

