



الأكاديمية العربية للعلوم والتكنولوجيا والنقل البحري

Arab Academy for Science, Technology & Maritime Transport

2013 Technical Report

2013 MATE International ROV Competition AASTMT Splash Marine Company (SMC) Maximilian ROV

Alexandria, Egypt

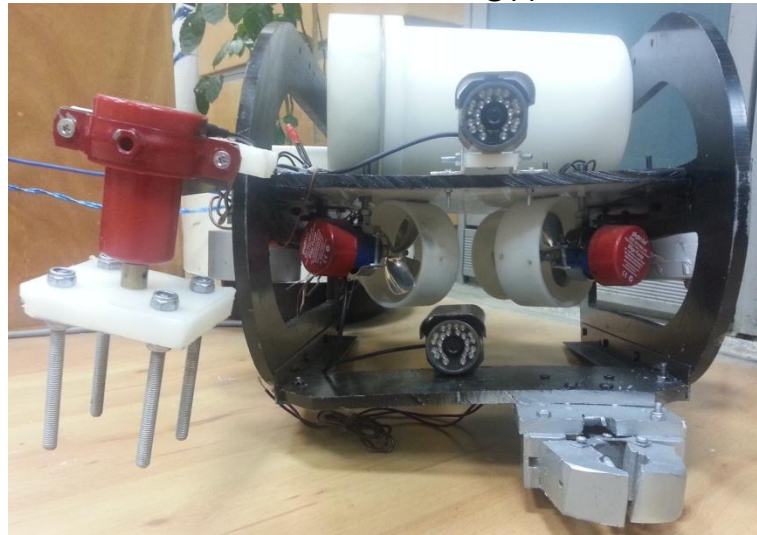

Team Members

Mentors

Prof.Dr. Mohamed Abbas Kotb

Prof.Dr.Ossama Ismail

Name

*Ahmed Mahmoud Ramy
Abdulrahman Jamal Abuelkhair
Eslam Gaber fakhry
Mohamed Mahrous AboElma'aty
Abdalmajeed Bassam Shublaq
Mai Zakaria Faramawy
Mohamed Abdalhameed Elbana
Ziad Mostafa Mohamed
Ahmed Mansour Zaki
Bola Morise Fawzy
Salah Mohammad Amen*

Position

*Team Captain (CEO), Pilot
Control Manager, Programmer
Marine Engineer, Co-Pilot
Marine Engineer, Tether man
Electrical Engineer, Technical writer
Secretary, Technical writer
Mechanical Engineer, Poster
Electrical Engineer, Media
Financial Manager, R&D
Safety Manager, Media
Mechanical Engineer, R&D*



2013 Technical Report

Abstract

Maximilian ROV is our company's fully functional product resulting from six months of dedication and hard work, encompassing various meetings and approximately 14 workshops. The ROV was designed carefully in order to compete in the 2013 MATE international ROV competition. Main features of Maximilian ROV include surveying sites, installing nodes, measuring distances and removing bio-fouling.

With dimensions of 52.5 cm length, 35 cm width and 35 cm height Maximilian ROV relies on six thrusters, four thrusters in vertex position for horizontal and lateral movement and two for vertical movement, it is also equipped with two main grippers, hooks and two cameras to ensure clear vision of our ROV and surrounding medium.

Power and motion electronics were assembled and modified carefully, but our software was developed and coded from scratch via open source modifiable Arduino software allowing the user swift correction of any fault, furthermore the ROV's design enables adding or removing any extra hardware or required software.

Safety is our company's main priority, with that in mind many additions have been inserted, for instance, safety labels have been added, Control box is removable in order to fix any problem as soon as it happens and our electronic system ensures preventing current from increasing drastically. Maximilian ROV is the perfect candidate for ocean observing demands because it is fully equipped however; its fabrication was quite affordable and operates in a user-friendly manner.

This detailed report will take you through the design and construction process step by step, as well as expenses, safety consideration and future modification.



| | | | | | | | |
|--|--|---|--|---|--|---|---|
| Ahmed Ramy | Eslam Gaber | Abdulrahman Jamal Abuelkhair | Mohamed Mahrous Abo Elma'aty | Abdalmajeed Shublaq | Mai Faramawy | Ziad Mostafa | Mohamed Elbana |
| Mechanical Team Marine Major 10 th Semester | Mechanical Team Marine Major 10 th Semester | Electrical Team Mechatronics Major 8 th Semester | Mechanical Team Marine Major 10 th Semester | Electrical Team Electrical Major 8 th Semester | Electrical Team Electronics Major 6 th Semester | Electrical Team Electrical Major 6 th Semester | Mechanical Team Mechanical Major 8 th Semester |

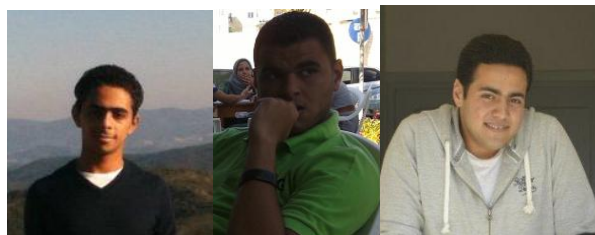

| | | |
|--|--|--|
| Bola Morise Fawzy | Ahmed Mansour Zaki | Salah Mohammed Amen |
| Mechanical Team Marine Major 10 th Semester | Mechanical Team Marine Major 10 th Semester | Mechanical Team Mechanical Major 10 th Semester |



| | |
|-------------------------|------------------------------|
| Prof.Dr. Mohamed | Prof.Dr.Ossama Ismail |
| Mentor | Mentor |



2013 Technical Report

Table of Contents

| | |
|--|----|
| ABSTRACT | 1 |
| BUDGET AND FINANCIAL STATEMENT | 2 |
| DESIGN RATIONALE | 3 |
| Frame | 3 |
| Thrusters..... | 4 |
| Housing /Enclosure..... | 5 |
| Buoyancy..... | 6 |
| Manipulators..... | 6 |
| ELECTRICAL AND CONTROL SYSTEM..... | 7 |
| Tether..... | 7 |
| Electronics unit..... | 7 |
| Software..... | 8 |
| Camera and lights | 9 |
| SAFETY | 10 |
| Workplace Safety..... | 10 |
| ROV Safety | 10 |
| MISSION SUMMARY..... | 11 |
| COMPANY PROFILE..... | 11 |
| PAYLOAD TOOLS..... | 12 |
| Task 1..... | 12 |
| Task 2..... | 13 |
| Task 3..... | 13 |
| Task 4..... | 14 |
| CHALLENGES..... | 14 |
| Technical Challenge..... | 14 |
| Non-Technical Challenge..... | 14 |
| TRUBLESHOOTING TECHNIQUES..... | 15 |
| FUTURE IMPROVEMENT | 16 |
| LESSONS LEARNED AND SKILLS GAINED | 16 |
| Technical Lessons Learned | 16 |
| Interpersonal Lessons Learned | 17 |
| TEAM REFLECTION | 17 |
| TEAMWORK AND ORGANAIZATION | 18 |
| OUTREACH..... | 19 |
| WARRANTY..... | 19 |
| REFERENCES..... | 19 |
| ACKNOWLEDGMENTS..... | 20 |
| APPENDIX A- Power Distribution Schematics..... | i |
| APPENDIX B- Safety Checklist..... | ii |



2013 Technical Report

BUDGET AND FINANCIAL STATEMENT

| Item | Expense Cost EGP/unit | Re-used Cost EGP | Total Expense Cost EGP | Total Expense Cost \$USD |
|--------------------------|-----------------------|------------------|------------------------|--------------------------|
| Relay module | 2 × 80 | | 160.00 | 22.92 |
| DC/DC Converter | 1 | | 1400.00 | 200.57 |
| Heat Shrink Tubing | 1 | | 45.00 | 6.45 |
| Camera | 4 × 600 | | 2400.00 | 343.84 |
| Motors | 6 × 350 | | 2100.00 | 300.86 |
| Fuse Board | 1 | | 30.00 | 4.30 |
| Power Supply Board | 1 | | 15.00 | 2.15 |
| Polyethylene | 1 | | 1000.00 | 143.26 |
| Gripper | 4 × 350.00 | 1400.00 | | 0.00 |
| Transmissometer | 1 | | 80.00 | 11.46 |
| Propellers | 6 × 100.00 | | 600.00 | 85.95 |
| Electronics Tube O-Rings | 3 × 17.00 | | 50.00 | 7.163 |
| Steel Bolt | 4 × 9.0 | | 36.00 | 5.16 |
| Camera Cable | 2 × 35.00 | | 70.00 | 10.03 |
| Data Cable | 2 × 112.5 | 112.5 | 112.5 | 16.12 |
| Power Cable | 1 | | 200.00 | 28.65 |
| Machining | 1 | | 255.00 | 36.53 |
| Arduino Mega ADK | 1 | | 460.00 | 65.90 |
| Arduino UNO | 1 | | 150.00 | 21.49 |
| Electrical tools | | | 410.00 | 58.74 |
| Mechanical tools | | | 85.00 | 12.18 |
| Printing | | | 235.00 | 33.67 |
| Group airfare | 13×8376.00 | | 108888.00 | 15600.00 |
| Van Rentals | 2×3490.00 | | 6980 | 100.00 |
| Accommodation | 3×9004.20 | | 27012.6 | 3870.00 |
| Team shirts | 12×130.00 | | 1560.0 | 223.50 |
| Total | | | L.E 154334.10 | \$ 22110.9 |

NOTE: Conversion rates at the time of calculations (19 May 20, 2013, 21:05 GMT)

is equal 1.00 USD = 6.98694 EGP

All expenses were covered by the Arab Academy for Science, Technology and Maritime Transport.



Design Rationale

Frame

Maximilian ROV's frame (Figure 2) is designed for optimum functionality, with curved edges and lack of sharp ends proven to provide smooth motion underwater as the curved edges decrease the frictional resistance of the body and increase its velocity. With weight of 4 Kg, Maximilian's frame is adequately heavy to support it and gives excellent buoyancy. The unique frame fits all components with ease; enough space is given to ensure zero interference and maximum efficiency.

In order to design and construct the frame, various sketches were made with different dimensions (Figure 3). Materials considered were Aluminum (like last year), PVC, polyethylene, steel, galvanic steel and stainless steel.

Our choice was set on polyethylene because our company's main aim is to produce a functional ROV, not just for simulations and competition purposes, but also for real life uses. Unlike galvanic steel which is subject to corrosion from salt water in a couple of years, polyethylene does not corrode and unlike PVC which is not durable and does not withstand high water pressure, polyethylene can endure deep water pressure. The frame's final design was modeled on 3D CAD System Solid Works™ which gave us the ability to decide the shape of the vehicle and the required dimensions and perform the stress analysis on the Frame.

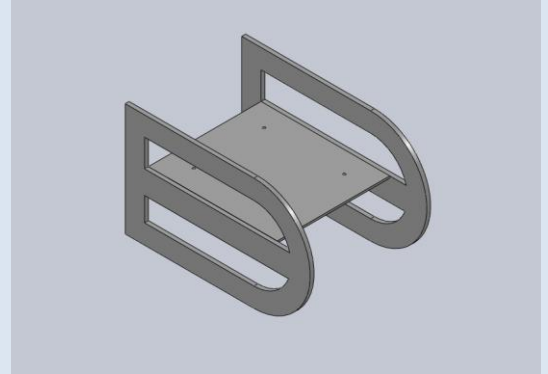

Fig.2 - Maximilian ROV Frame

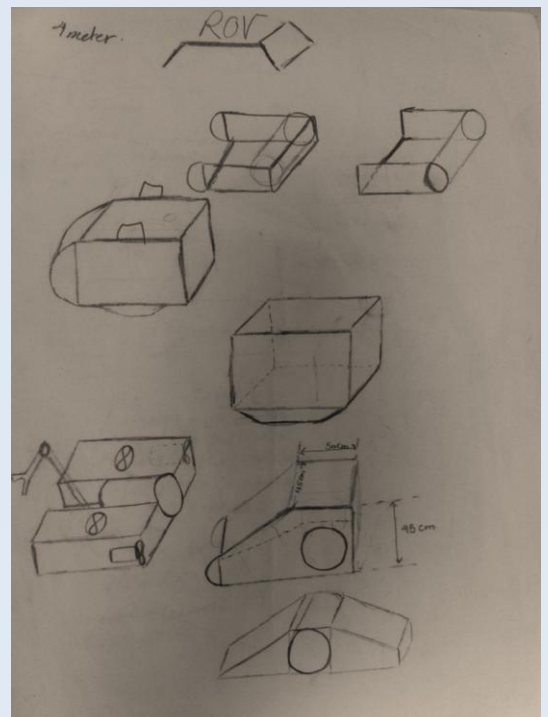

Fig.3 - First sketches of ROV's Body

Figure 4 shows SolidWorks™ analysis on one side of the frame at 20 meters water depth having mass of 1.32443 Kg, volume of 0.100145862 m³, density of 908 kg/m³ and weight of 12.9794 N. Its tensile strength is 3.4e+007 N/m² that showed the ability to withstand pressure of 196200 N/m². Then, blocks of polyethylene were purchased and the final exact measurements of dimensions were handed to the Industry Service Complex at the Arab Academy campus which is a very professional machining resource that provided us with the reshaped frame.

Reshaping the polyethylene blocks could have been easily done by our capable team of engineers but this was going to be time-consuming. As explained earlier, polyethylene is already protected from corrosion so the frame does not require any extra measure to prevent its corrosion.

Thrusters

Rule Bilge pumps (Figure 7) are used as thrusters; these pumps are produced for general aquatic purposes so they are already sealed and ready to use.

$$RT = \frac{1}{2} * \rho * S * V^2 * C_f$$

After calculating the resistance that acts on the body of Maximilian by assuming submarine shape of the ROV and the calculating the power developed which is equal to 17 Watt after being multiplied by safety power factor we decided to use the motor of bilge pump as its power is suitable for the motion of the vehicle. With a flow rate of 500 GPH (*Gallons Per Hour*), 12 volts DC at 1.9 Amperes and 5 Amperes after being loaded and power of 60 watts these pumps were chosen. The outer pump is dismantled and the impeller is slipped off in order to mount a propeller covered with Kort nozzle for safety as in Figure 8.

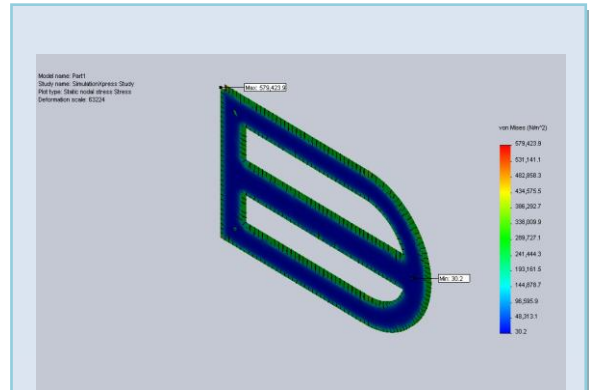

Fig.4 - stress analysis of frame using SolidWorks™.

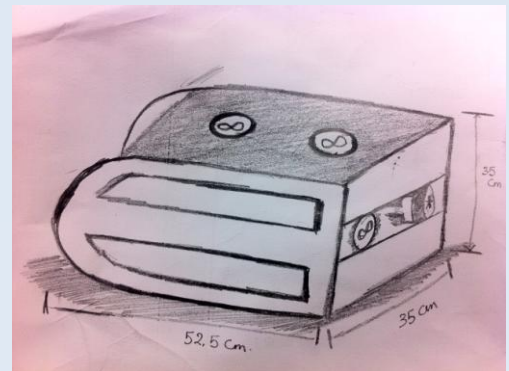

Fig.5 -Early design sketches of ROV Maximilian.

Ten Bilge pumps are used, six for motion; four of which for horizontal and two for vertical movement, Horizontal motion thrusters are positioned at 45° for maximum efficiency, giving higher degrees of freedom for moving in all directions and less errors in guiding Maximilian ROV. This differs from last year's 90° installation which provided limited motion. In order to choose this particular way of positioning thrusters, power was calculated manually and specific books and doctors were referred to for advice .Two more thrusters are installed for vertical motion. New propellers were designed and cast, the selection of propellers was done with the aid of $B_p - \delta$, 3 blade, BAR 0.5 graph. (Figure.6) $B_p = \frac{N * \sqrt{P_d}}{V_A^{2.5}}$ We obtained from it the dimensions of the propeller which are 8 cm disk area, 1 cm boss diameter and 6 cm pitch. Four Bilge pumps are used as payload tools that are recycled from last year's ROV and refurbished for money-saving. The rest of last year's thrusters could not be recycled because after thorough testing their reuse was found to be impossible and are being used now for educational purposes and further testing. Two bilge pumps are used for the arm grippers and the last two are used for special manipulators to perform specific missions. Apparent disadvantages of bilge pumps lies in the fact that they were not specifically designed for ROVs production, but previous experience with that particular brand last year gave us confidence that they are capable of effectively driving Maximilian ROV.

Electronic Enclosures

Housing is in the form of an insulated utility case of brand "T.Z Case International Cape Buffalo Molded Utility case" ordered from Amazon.com (Figure 9). Dimensions are 19.5 cm*10.7 cm*8.89 cm. It has a pressure release valve and convoluted foam lid and base. Consumer comfort is a main interest for Splash team and the case is visually appealing to the eyes. If a problem occurs the electronic enclosure with its

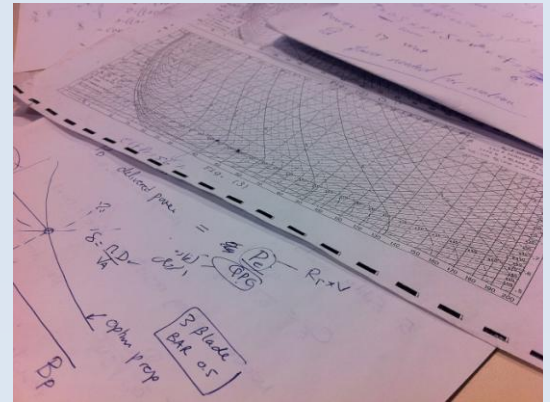

Fig.6 -Selection of propeller graph.



Fig.7 - Bilge Pump before modification.



Fig.8 - Thruster components .



2013 Technical Report

components is easily removed for fixing, handled outside the ROV and returned back again. Another option of electronic enclosure made of polyethylene is being constructed (Figures 11). Dimensions of the polypropylene tube are 30 cm length, 18 cm outer diameter and 15 cm inner diameter. It is characterized by a 4-stage water-proofing technique, consisting of 3-stages of O-rings and a stage of a water gasket. If its manufacturing is finished on time and proved to be water-proof, it will be used instead of the commercial case. Figure 10 shows the SolidWorks™ simulation of the enclosure.

Buoyancy

Neutral buoyancy equation was used for buoyancy calculation.

$$\text{Buoyancy Force } B_f = \rho * V_{rov} * g$$

$$= 1000 * 0.0145145188 * 9.81 = 142.42 \text{ N}$$

$$\text{Weight of ROV} = m_{rov} * g = 15 * 9.81 = 147.15 \text{ N}$$

The Vertical net Force act on the ROV

$$= B_f - \text{weight}_{rov} = 147.15 - 142.42 = 4.73 \text{ N}$$

We are much more alert this year to buoyancy and balance problems than previous years, The case before was that the team would be more keen on producing the body first then it was balanced later by the means of adding weights or water bottles. This year all calculations were made first including the choice of using polyethylene for the frame and testing it under water for maximum balance (Figure 12).

Manipulator

Two main polyethylene manipulators are installed that will cover most major tasks in missions assigned to Maximilian ROV from carrying SIA, installing nodes, holding sensors to removing biofouling (Figure 13). Two special manipulators are designed by our mechanical



Fig.9- T.Z Case International Cape Buffalo Molded Utility case.

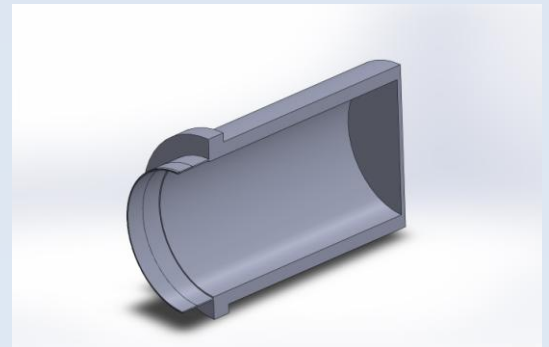

Fig.10- Polyethylene Enclosure designed using SolidWorks™.



Fig.11- Polyethylene Enclosure.



2013 Technical Report

team consisting of the recycled bilge pump with four screw guides of diameter 7 mm bolted to a polyethylene base held to the bilge pump with aluminum coupling,. These two grippers will be used for any rotation motion and will be used to rotate the leg of the secondary node to balance it.

ELECTRICAL AND CONTROL SYSTEM

Tether

Maximilian ROV tether consists of one 16 mm 40A power cable as it requires high power, two data cables to transmit signals between analog joystick and Arduino microcontroller board and three camera cables all covered with heat shrinks. Data and power cables are made of copper hair wires instead of regular TTL (*Transistor-Transistor Logic*) wires for much more powerful signal transmission.

Electronics Unit

The electronic system of Maximilian ROV is a very reliable one. Each component was considered from all possible angles and efficiency and cost trade-offs were made in favor of efficiency.

Thrusters used operate at 12V DC so voltage is dropped from source (48V) using a readily bought step-down buck DC-DC converter of mean well SD-500L-12 brand (Figure 14) that gives output 12 V DC at 40A for DC input of 24-72 V, and its dimensions are 21.5cm *11.5cm*5.0 cm and added safety features of short circuit/over load/over voltage/over temperature input polarity (by fuse) and high heat tolerance by means of forced air cooling through built-in DC fan with fan



Fig.12- Testing Buoyancy.

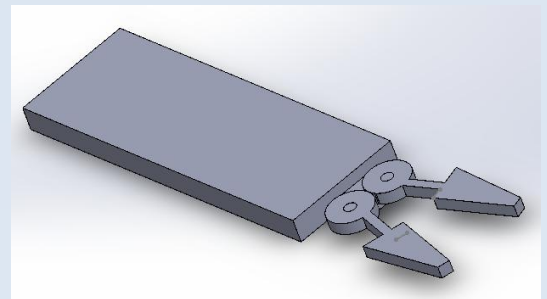

Fig.12 - One of the first designs of Primary manipulator.

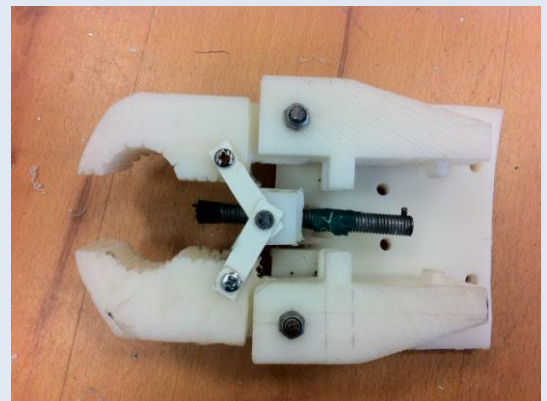

Fig.13- Primary manipulator.

2013 Technical Report

speed control function. DC converter could have been designed and produced by our highly capable team of engineers but this was going to be time-consuming.

Relay module (Figure 15) is designed using Eagle CAD software used for thrusters directional control. Relays used are of type Qianji JQC-3F (T73) 10A at 28VDC and IC ULN 2003 acting as a medium for transmitting signal from microcontroller to relay.

Two relay modules are used to control the ten thrusters. Each module consists of twelve relays. Every two relays are responsible for controlling the direction of one thruster so we have two extra relays added for back-up. This module contains LED indicators for each thruster.

A voltage regulator power supply board designed from a to z is made from scratch by our electrical department, providing voltages of 12V, 10V, 6V, 5V and a common ground. Equipped with labeled pin-headers, rosettes and LED indicator lights (Figure 16).

Software

Maximilian ROV software is simple but effective; it consists of two main parts; the base-station software at the pilot side and the on-board underwater software. Base-station software uses input from a joystick, written with open source available Arduino software. Some readily available libraries are used for controlling movement.

The link On-board electronics consist mainly of an Arduino Mega ADK board. Focusing on the Arduino microcontroller (Figure 17), this exact brand was chosen although it was expensive compared to its sisters as it has a powerful processor ATmega 2560 and it features an ATmega8U2 programmed as a USB-to-serial converter. Its length and width are 10.2 and 5.3cm respectively attachable through screw holes to surfaces,



Fig.14 –DC/DC converter used.

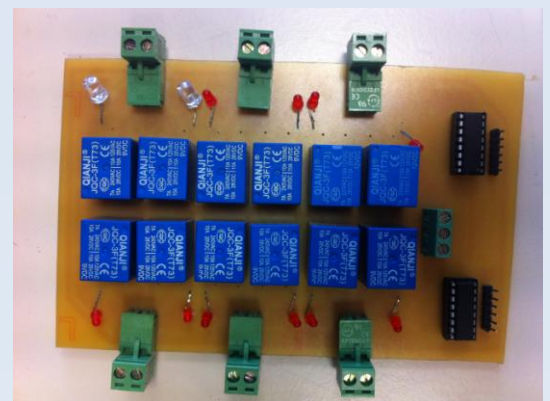

Fig.15- One of 8 motor drivers used.



Fig.16 – Voltage Regulator board (12V, 10V, 6V, 5V, GND).



2013 Technical Report

operating at 5V, 7-12 input voltages and DC current of 40 mA having 54 Digital I/O pins, 15 of which provide PWM (pulse width modulation) output, and 16 Analog input pins and equipped with a boot-loader to upload new code to it without the use of external hardware programmer.

Camera and Lights

Three water-proofed CCTV cameras of model HST-IR2124 with dimensions of 8.55cm*6cm*6.1cm are installed (Figure 18) with image sensor of 1/3"760H CCD and internal synchronization that operates at 12V DC and consumes maximum 120 mA at IR OFF and 350 mA at IR ON, one on the arm gripper to give us the exact knowledge of the gripper's position relative to the objects around it. Trial and error and last year's experience led us to believe that this position is the ultimate one. While the second camera is installed for overhead view of Maximilian ROV to know the bearings of surrounding medium in order to aid in missions such as adjusting the legs to level the secondary node and ensuring that our precious ROV never gets lost.

Last year a different brand of camera was used and waterproofed manually. This year's camera is a much better option as it is an infrared one with an IR LED of 24EA so no external LED is needed as perfect night vision is obtained with 100% water-proofing and no interference occurring through having camera wiring next to rest of the tether components so we did not need to separate them.

Maximilian ROV is equipped with two torches to simulate real life ROVs. They are installed at the front of Maximilian's body at both sides. This will facilitate the ROV's vision in deep water regions and in turbid areas.

Note: (Power Flow Schematic) refer to Appendix A

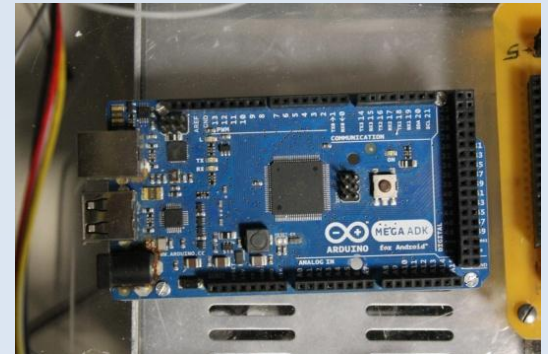

Fig.17 –Arduino Mega ADK board



Fig.18 - CCTV cameras



Safety philosophy

SMC considers safety and health of all employees to be the most important aspect of our work. The company will comply with all workplace safety requirements set forth and a safety manager will be responsible for maintaining all safety issues. He will use the company's safety check list daily to conduct routine inspections (Refer to appendix B).He will also ensure employees are equipped with necessary protective equipment and that they are using tools in a safe way. Furthermore, he will enforce these safety rules and investigate accidents to prevent them occurring in the future.

Workplace safety

Workplace safety includes:

- Safety labels throughout the workshop.(Figure 19).
- Employee training in workshop safety.
- Goggles used during cutting and welding of mechanical parts.
- Using fixed tools in workshop like saw station instead of saw.
- Life jackets are required during ROV testing in water.

Maximilian ROV Safety features

- Safety electrical labels on vehicle (Figure 20).
- Using propellers with shrouds on each propeller.
- Heat shrinks used extensively.
- Curved and rounded edged frame.
- Fuse board withstanding 10 A designed by our electrical team. Inserted before motor drivers put there for precautionary measures as motor drivers can withstand more than the 10 A current.
- LED indicators on the voltage board, giving ON state



Fig.19 - Safety Labels throughout the lab.



Fig.20- Safety Labels on Vehicle.

for voltage in use from the 12V,10V,6V and 5V used to make sure they operate normally.

-A high sensitivity water detection sensor module of model 1SEN11304P (2.0 cm × 2.0 cm) is used to detect liquid leakage. (Figure 21).

This sensor works by having a series of exposed traces connected to ground and interlaced between the grounded traces are the sensors traces. The sensor traces have a weak pull-up resistor of 1 MΩ. The resistor will pull the sensor trace value high until a drop of water shorts the sensor trace to the grounded trace so the voltage increases as the amount of water increases.

- Arduino ADK microcontroller has a resettable polyfuse that protects USB ports from shorts and over currents, providing an extra layer of protection .If more than 500 mA is applied, the fuse will automatically break the connection until the short or overload is removed.

MISSION SUMMARY

Company Profile and Mission

SMC is a company founded in 2011 and based in Alexandria, Egypt. For three years in a row we have been working in the field of designing, producing and delivering ROVs to customers worldwide gaining vast experience in this domain. Annual increase in the number of start-ups producing ROVs led to a huge competition, but this will only make us strive to become better and produce higher quality ROVs to keep up and lead in this field. RIC only recruits competitive, innovative and highly qualified individuals and also trainees who despite having little experience in ROVs are hard workers and eager to learn more with each passing second.

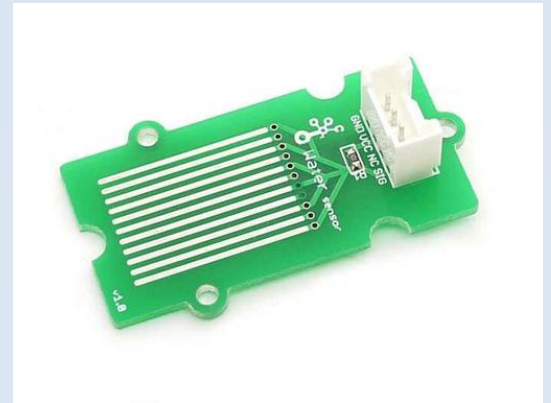

Fig.21- water detection sensor.



Fig.22- Cabled ocean observatory, Courtesy of www.2i-3.com



2013 Technical Report

As said earlier we have produced ROVs before ready for underwater exploration and performing missions with care and precision. In 2011, we delivered an ROV to help with oil spill problems the Gulf of Mexico and last year we delivered a second ROV for the purpose of surveying shipwrecks left over from World War II.

Our ROV will play a huge role in this field in the RSN area (Regional Scale Nodes) where it will be positioned as it is impossible for humans to reach these deep ocean levels so our Torbini ROV will be required to extend network of cables and nodes, it will also replace sensors, remove bio fouling and perform constant maintenance on existing systems. It will be required from our ROV to perform the following tasks:

PAYLOADS TOOLS

Task 1

Completing a Primary node and installing a secondary node

Maximilian's mission starts at the initial 5 minutes setting time were the ROV will carry the SIA (Scientific Interface Assembly) and the ADCP (Acoustic Doppler Current Profiler) with both of its hooks (Figure 23) and be prepared to take them down to the seafloor at the start of the mission, while the turbidity sensor (Transmissometer) is held with the manipulator, this is when presence of multiple hooks comes in handy. SIA is inserted via the gripper into the BIA (Backbone Interface Assembly). CTA (Cable Termination Assembly) will be removed from sea floor and held with gripper then inserted to the Bulk head connector of the BIA; pin released with the aid of the gripper, then the secondary node will be held with gripper and removed from the elevator.



Fig.23- Hook used in Maximilian ROV.



Fig.24- model of playground with exact dimensions as in missions.



2013 Technical Report

Distance is going to be a bit tricky to measure but since the speed of the ROV is already known, time will be measured and distance will be calculated (Distance = speed *time), calculated distance will be added to the rest of known distance in order to pinpoint the designated location for putting secondary node. After the secondary node is placed, fork-like holders (screw guides) installed atop of recycled bilge pump designed especially for this task (Figure 25) will hold on to the leg of secondary node and the motor will rotate adjusting the legs in the process, simultaneously the bubble scale will be viewed by the camera in order to balance the legs. BIA door is opened with the manipulator, secondary node is removed also with arm gripper, a 90° hook at ROV's side is used to open door on the BIA, Finally the cable connector is inserted for power and communication.

Task 2

Design, Construct and install a transmissometer to measure turbidity over time.

SMC group designed and produced an optical beam transmissometer (Figure 27) separate from our ROV .This special sensor was produced from A to Z, circuit was tested and insulated completely from water then supplied with power. It consists of a PVC frame on which the sensor is placed .The sensor consists of a laser beam transmitter placed inside the PVC frame on one side and a receiver on the other side. The receiver consists of a photo resistor (LDR).The photo resistor will take the analog readings of resistance, convert the readings to variations in voltage using signal conditioning and then send the data to the Arduino microcontroller. Then the microcontroller will plot a graph of the attenuation of light (opacity) with time on a video display.

Task 3

Replace an Acoustic Doppler Current Profiler (ADCP) on a water column mooring platform.



Fig.25- Specially designed manipulator for missions.

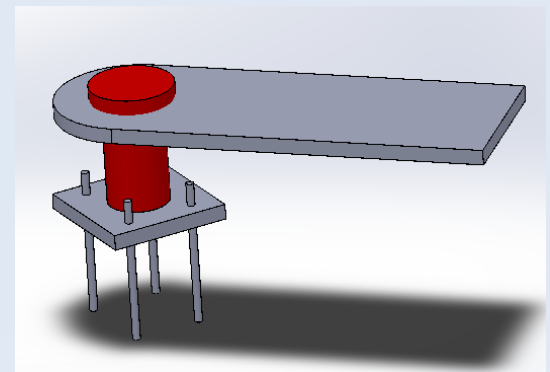

Fig.26 - -SolidWorks™ Render of Specially designed Arm for balancing legs in mission one.



2013 Technical Report

As stated in mission one, Maximilian ROV will carry the ADCP down at the start, power is then disconnected from the hatch with the aid of the arm gripper, hatch is unlocked with gripper too, after wards the hatch is opened with the gripper held in closed position and the old ADCP is removed with the gripper and replaced with the new one, hatch is then closed and locked in reverse and finally power is connected again using arm gripper.

Task 4

Locate and remove bio fouling from structures and instruments within the observatory.

Throughout Maximilian ROV's mission it will locate bio fouling seen by cameras and will be removed from surfaces with the arm gripper and will be left on sea floor.

CHALLENGES

Technical Challenges

The biggest constant challenge that spans not only this year's construction process, but also previous years and affects most start-up companies like us is sealing the ROV (Figure 28). We learnt a lot from our past experiences with sealing and reached this year the best sealing technique. This year a new method was thought of and designed after many trials and errors, testing underwater using tens of materials ranging from Epoxy, gasket sealing, silicon, and foam. Our new method of using the commercial utility case or the designed polyethylene tube enclosure and O-rings in between has proven to be 100% sealed as they protect all on-board components.

Non-Technical Challenges

Another huge non-technical challenge is time factor. The Arab Academy generously provided lab rooms and



Fig.27- Transmissometer Sensor.



Fig.28- Testing the sealing technique.

workshops for us to work in on campus, but our campus unfortunately is located on the fringe of the city. It takes approximately one hour driving from traffic congested down town Alexandria to reach the campus. Extremely late departure time was a big problem with most of our team members who were also struggling to keep up with college and lectures. Most of the team members participating this year are hard workers at college and keen on attending all their lectures so they were under pressure on the educational level more than ever attending, studying, staying at the workshops and leaving late at night. Repeating this almost daily became a challenge overcome only by the remarkably strong team spirit.

TROUBLESHOOTING

Troubleshooting is an important process that was utilized by our team during the project. Each part of the ROV was tested after it was produced and then when the whole vehicle was built, it was tested under water numerous times. Whenever we were faced by a problem we used the technique shown in Figure 29. We identified the problem correctly then we developed alternative solutions and chose the best alternative. Finally, the chosen solution was implemented.

One of the problems faced was that after we installed the cameras in our ROV and fixed them tightly, one camera experienced problems in video streaming as the image quality was distorted and accompanied by noise. We used our technique of problem solving: Alternatives were either replacing the malfunctioning camera, using the camera as it is or cutting its connector wiring and trying to fix it. The third option was chosen and the wire was cut, source of error was identified in the connection and it was fixed and the camera connector was welded back successfully. One other problem was that we were not sure that the electronic enclosure was robust and can endure high

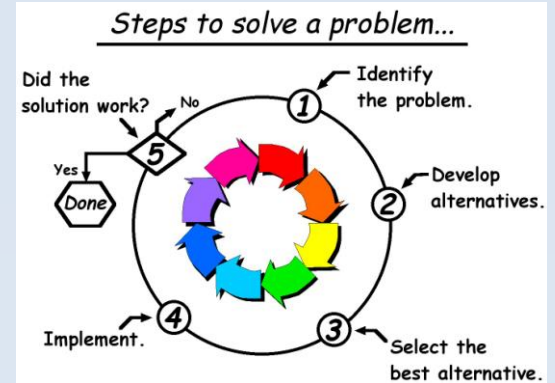

Fig.29- Our methodology of problem solving, courtesy of www.thecollaboratory.wikidot.com



Fig.30- Electrical Team discussing work plans



2013 Technical Report

water pressure. We used a rather primitive method of solving the problem, Team member Ahmed Ramy sat on the control box for a large interval of time and it was found to withstand weights.

FUTURE IMPROVEMENTS

Maximilian is subject to continuous changes and improvements whenever needed that will include:

- 1) Adding sensors to aid in motion.
- 2) A fourth camera will be added on a servo controlling its 180° or 360° view.
- 3) Our ROV is operating on an open-loop control at the moment, later it will be converted to closed-loop control giving feed-back and monitoring the situation ensuring live updates on everything including current for example and eliminating the need for fuses.
- 4) USB connection feature in Arduino board will be used in future improvements through controlling our ROV with Android smart phones.

LESSONS LEARNED AND SKILLS GAINED

Technical lessons learned

At first our mechanical department designed and constructed the ROV to operate using four thrusters only. Two thrusters were installed for vertical motion and two thrusters for horizontal motion. Power was calculated and the team thought that the resulting power, number and layout of thrusters were enough to drive Maximilian ROV and give it all the degrees of freedom it required.

However, after testing Maximilian ROV underwater, it became unstable and did not move smoothly. We had to change the number and way of installing thrusters



Fig.31- Discussing work progress and Future improvements



2013 Technical Report

completely. The new setting was using four thrusters positioned at 45° for horizontal motion (Figure 32) and two thrusters for vertical motion. We learnt from this example that we should not depend on our calculations and take them for granted. We should always test our progress step-by-step before finishing, so that we do not need to repeat the work again and waste time.

Interpersonal lessons learned

The project of building Maximilian ROV gave us lots of interpersonal skills. We were a micro-society consisting of old and new members from different majors, backgrounds and genders. We learnt a lot from each other, gaining skills of time management, organizational skills, and presentation skills. Technical aspects were passed over from older, more experienced members to the newer members. If there is one thing that can be modified next year that would be adhering to a stricter time frame so that we do not find ourselves loaded with tasks as our exam finals and the competition deadline drew near.

TEAM REFLECTIONS

"I have taken the ROV building process seriously, my sole aim for working on this project wasn't only to compete, I wanted our team to actually produce a real product with real live applications. I've enjoyed the atmosphere, new members' company and learning to work in an organized team. My future plans include teaching anyone interested in ROV designing all the information I have due to the three years of experience with ROVs. I have high hopes of our team becoming a leader in this domain"

Abdalmajeed Shublaq-Electrical Team

"Working on the mechanical parts helped me in my field of study, but what benefited me the most is learning all electrical, electronic and software aspects related to our ROV. I've gained essential skills that will aid me in

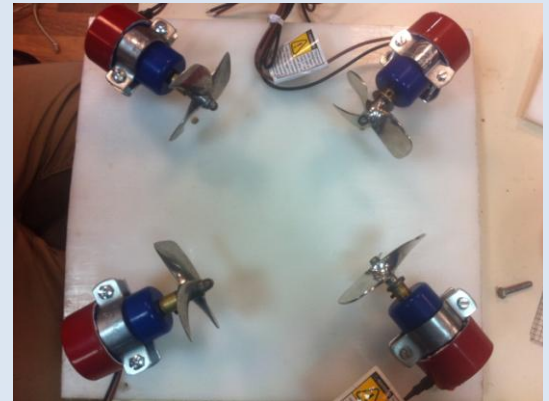

Fig.32- The new setting of thrusters positioned at 45° .

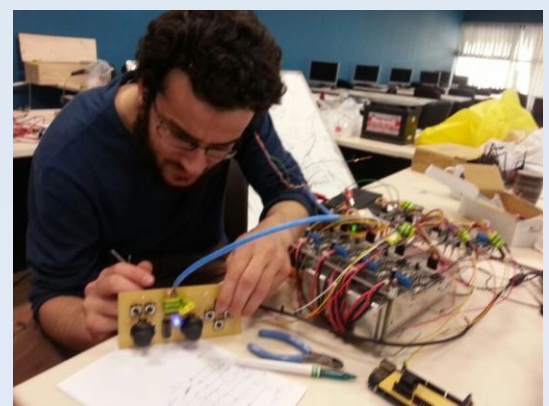

Fig.33- Abdalmajeed Shublaq-Electrical Team.



2013 Technical Report

any future project I embark. ROV's garnered my interest so much that I am considering pursuing an ROV-related career later".

Mohamed Elbana-Mechanical team

"Being a new member and the only female in the team was challenging at first, especially that I couldn't follow up completely at first because of late staying hours at college and my little knowledge in this field, but this experience could not have helped me more. Learning from much more experienced team members who are more than willing to provide every single bit of information they know and the hands on experience I've had will benefit me for a life time"

Mai Faramawy- Secretary

TEAMWORK AND ORGANIZATION

Maximilian ROV is a product resulting from the team work and interaction between all the team members of the company. All members were involved in all electrical, mechanical and logistical parts of the process but in order to organize the work in a better way certain measures were taken. A team hierarchy was established at the very first meeting. Each member was designated to a specific role of CEO, financial manager, electrical team leader, mechanical team leader etc...

Weekly meetings were held each Friday at college or at a café where team members would report the progress of their specific assignments and a schedule was set to aid in building the vehicle. During these weekly meetings, the team secretary was responsible for documenting the meeting proceedings, writing the schedule and the assignments. After that the meeting minutes were posted on our social media (FaceBook and Google) groups so that team members who could not attend the meeting can follow up and start working on their assignments.



Fig.34- Mohamed Elbana sealing the Artelon discs.



Fig.35- Mai Faramawy working on bilge pumps



OUTREACH

SMC group was always keen on spreading scientific knowledge especially ROV knowledge with fellow students and colleagues all year-round. Starting with a pre-workshops session given at our college (The Arab Academy for Science and Technology and Maritime Transport) in order to educate students as much as possible about remotely operated vehicles, continuing with other sessions spread throughout both semesters.

Warranty

To ensure your personal satisfaction of our product, for a period of 3 years after the original shipment from our company, Maximilian ROV manufactured by SMC group is warranted to function properly and be free of defects. If any malfunction is detected, a report should be filed to the company and the ROV will be fixed immediately by our engineers free of charge (or replaced if needed) at the company's expenses.

This warranty doesn't apply if, after complete professional inspection, it is determined that the damage is due to overloading, accidents or improper usage.

References

- 1) Harry Bohm and Vicki Jensen (1997) "Build your own underwater Robot and other wet projects".
- 2) Robert D-Christ and Robert L.Werlmi SR (2007)"The ROV Manual: A User Guide for Observation Class Remotely Operated Vehicles".
- 3) Ocean Observatories
"www.oceanservice.noaa.gov/oceans/ohn/"
- 4) Integrated ocean observing systems
"en.wikipedia.org/wiki/Integrated-ocean-observing-system".
- 5) What is a Transmissometer
"<http://www.wisegeek.com/what-is-a-transmissometer.htm>"
- 6) Electrical Safety Checklist
"<http://www.worksafe.act.gov.au/publication/view>"



Fig.36-AASTMT



الأكاديمية العربية للعلوم والتكنولوجيا والنقل البحري

Arab Academy for Science, Technology & Maritime Transport

2013 Technical Report

Acknowledgments



الأكاديمية العربية للعلوم والتكنولوجيا والنقل البحري

Arab Academy for Science, Technology & Maritime Transport



SMC ROV Company would like to thank:

AASTMT for the financial support, hosting the regional competition and allowing us to use the pool.

Prof. Dr. Mohamed Kotb and Prof. Dr. Ossama Ismail for mentoring and providing technical support.

All the volunteer judges of the regional competition.

Eng. Mohammed Fouad for providing engineering consultations and advices.

Regional Informatics Center (RIC) for providing us the Electrical Engineering Lab and the Mechanical work shop.

Industry Service Complex AAST for being such a great machining resource.

Our colleagues Ahmed Zaghloul and Mohanned Mohamed.

for providing continuous support in the mechanical aspects of our work

Our family for supporting us and putting up with us during the building season.



2013 Technical Report

Appendix A - Power Distribution Schematics

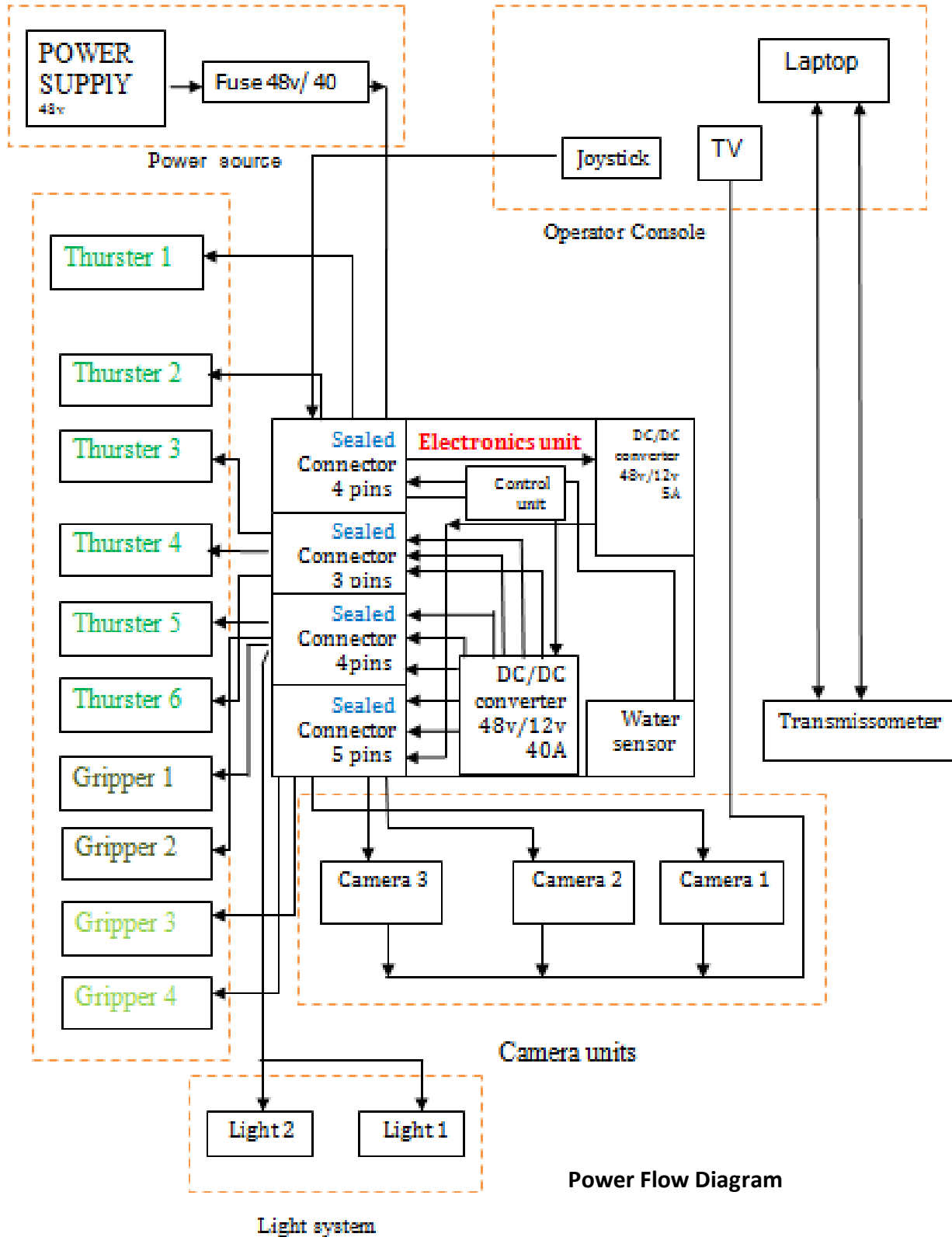



2013 Technical Report

Appendix B

Splash Marine Company (SMC)

Safety Department
Alexandria, Egypt
Tel: +20 (0) 114 373 88 2
: +20 (0) 128 98 278 2

Safety Inspection Checklist

Date of Inspection

Time of Inspection

| | |
|-----|--|
| / / | |
|-----|--|

Inspected by

| | |
|----------|--|
| Name | |
| Position | |

Also present

| | | | |
|----------|--|----------|--|
| Name | | Name | |
| Position | | Position | |

| | | | |
|--|--|--|--|
| | | | |
| | | | |

Safety manager:.....

Signature

Chief Executive Officer.....

Signature



2013 Technical Report

1. KEY STAFF

| | | |
|-----|------------------------------|--|
| 1.1 | Section Safety Officer (SSO) | |
| 1.2 | Laser Safety Officer | |
| 1.3 | Electrical safety officer | |

Comments:

2.WORKPLACE

| | | |
|-----------------|---|--|
| Lighting | Are all areas of the workplace adequately lit? | |
| Housekeeping | Is the workplace kept generally clean and tidy? | |
| workplace tools | Is there sufficient and appropriate storage? | |
| Machines | Machinery has been identified that may expose workers to electrical risk | |
| Power point | Are all power points, light fittings and switches in a safe place and free from obvious | |

Comments:

| | | |
|----------------------------|--|--|
| Noise | Is the workplace too noisy? E.g. Do you have to regularly speak in a raised voice to make yourself heard by colleagues standing within 1 or 2 Metres | |
| | Is suitable hearing protection provided if noise levels cannot be reduced by other means? | |
| workplace lables and signs | Are hazard-warning and advisory signs appropriately distributed throughout the Section? E.g. Biohazard, Fire escapes, Electrical , etc | |

Comments:

3.FIRE

| | | |
|------|---|--|
| Fire | Is all escape routes free from obstacles, including furniture, filing cabinets, electrical equipment, lockers etc? | |
| | Have all Team members been given full instruction and training in escape and assembly points, and fire precautions? | |

Comments:



2013 Technical Report

4. ELECTRICAL

| | | |
|-------------------|--|--|
| Electrical Safety | Are there any exposed, loose or entangled wires or connections? | |
| | Are switchboards and electrical equipment in a safe condition? | |
| | Electrical equipment has been tested | |
| | People working with electricity have been given information, instruction and training | |
| | Portable cable stands are used when required | |
| | Is all 'plug in' electrical equipment subject to regular Portable Appliance Testing by a competent engineer? | |

Comments:

FIRST AID

| | | |
|-----------|---|--|
| First AID | Is there at least one fully equipped first aid box provided in the workplace? | |
| | Are fire extinguishers clearly marked and regularly checked and maintained? | |
| | Are first aid provisions (including appropriately-trained first aid staff) available? | |
| | Are workers aware of where first aid provisions are kept? | |

ADDITIONAL COMMENTS

| |
|--|
| |
|--|

NAME AND SIGNATURE OF PERSON LEADING THE INSPECTION

Date

Name

Signature

| | |
|--|--|
| | |
|--|--|