

Technical Report



TigerSharks ROV 2015-2016 Dalhousie University, Halifax, Nova Scotia, Canada



Acknowledgements:

The following people and organizations made this report possible: MATE Center and Marine Technology Society – For sponsoring the competition. Dr. George Jarjoura -Mentorship & Workshop, Dr. Mae Seto -Team Mentor, Piotr Kawalec -Engineering Team Coordinator, Angus MacPherson -Metal Shop Supervisor, Reginald Peters -Wood Shop & 3D printing supervisor, Mike Duggan -MATE Regional Coordinator, Dr. Darrel Doman –Mechanical Engineering Department Head, Andrea Felling - Mentorship

Staff:

Samuel Levac-Levey- '17 Mechanical Engineer, CEO
Megan Behrens- '18 Electrical Engineer, Vice President, Electrical Co-Lead
Mu He-'16 Electrical Engineer, Electrical Co-Lead
JungHo Park- '16 Electrical Engineer, Thrusters Lead
Andrew MacMaster- Enclosures Lead
Jerrett DeMan- '19 Computer Science, Chassis Co-Lead
John Lee- '18 Mechanical Engineer, Thruster Team
Kent Nielsen- '20 Engineer, Chassis
Sam Fresia- '18 Electrical Engineer
Patrick Hennessy-'17 Mechanical Engineer, Thruster Team
Akshay Shirke-'17 Science in Economics, Treasurer
Thomas Brennan- '18 Mechanical Engineer, Tools Team
Benjamin Laird- '16 Environmental Engineer, CFO
Alexander Dewar- '20 Engineer
Aleksander Jack- '18 Electrical Engineer
Beau Rogers- '18 Electrical Engineer
Santiago Osorio- '16 Mechanical Engineer

A. Introduction

I. Abstract

This report outlines the design and functionality of the Stingray, a tethered underwater robot (ROV) used to collect data and complete mission-specific tasks at depths up to and beyond 40ft. The Stingray was designed to comply with severe size and weight restrictions in order to enable this ROV to be stored as payload on a spaceship destined for Europa. Along with this requirement, Dal TigerSharks maintained reliability, speed and precision as the key elements driving the design of this robot. These characteristics were made top priority as the mission at hand demands a machine robust enough to withstand the spaceflight to its final destination, rapid enough to complete the critical tasks within the narrow time frame and capable enough to perform all tasks in an efficient and effective way. The final configuration presented in this report meets this criterion wholly and demonstrates the high-level of detail that was involved in both the design and fabrication phases of this project. The design of the Stingray pushed new boundaries for this company and through a team-wide effort to maintain as many custom components as possible, the ROV utilizes very few off-the-shelf solutions. This provides the most optimized and efficient machine possible using tools and a configuration specific to the mission objectives.

Table of Contents

A. Introduction	i
I. Abstract	i
B. Company Structure & Organization	1
I. Team History	1
II. Long-term plan	1
III. Team organization	2
C. Design Rationale	3
I. Design Requirements	3
II. General Design	4
III. Chassis	5
IV. Buoyancy	6
D. Thrusters	7
I. Thruster Configuration	7
II. Thruster Design	9
III. Performance	10
E. Waterproof Enclosure	11
F. Electrical Systems	11
I. Power Supply System	12
II. Onboard processor	12
III. Tether	13
IV. Video	13
V. Sensors	13
VI. Pilot system	14
VII. Tools control circuits	15
G. Tools	15
I. General Rational	15
II. Payload Tools	16
I. Overall outcome	17
II. Learning experiences	17
III. Future improvements	17
Appendix	l
I. Safety check list	l
II. System Integration Diagram	ll
III. Final ROV Assembly Drawing	lll
IV. Full budget breakdown	llv

Table of Figure

Figure 1- PVC Frame.....	4
Figure 2- Skids & Frame	6
Figure 3- Depiction of righting moment underwater, Image from http://slideplayer.com/slide/8427378/	6
Figure 4- Vector Configuration, image from Dal ROV 2012 report.....	7
Figure 5- Cube Thruster Configuration	7
Figure 6- Calculations for 8-Vectored Configuration	8
Figure 7- Exploded view of Team Designed Truster.....	9
Figure 8- Cross-sectional of Duct.....	9
Figure 9- Thrust Test Platform of side and top views.....	10
Figure 10- Current VS. Thrust at 12V.....	10
Figure 11- Enclosure Sealed View	11
Figure 12- Enclosure Exploded View	11
Figure 13- System Interconnection Diagrams	15
Figure 14- Claw in Open & Closed Position	16
Figure 15- Cross section of claw	16
Figure 16- Enlarged View Poolside SID	II
Figure 17- Enlarged ROV Subsystem SID	II
Figure 18- Final ROV assembly drawing.....	III

List of Table

Table 1: Important Characteristics.....	3
Table 2: Material Information.....	5
Table 3: Thruster Calculations	8
Table 4: Advantages and Disadvantages for microcontrollers	13
Table 5: Team Project expenditure and income	IV

B. Company Structure & Organization

I. Team History

The first ever Dalhousie ROV team, the “Privateers”, was founded in 2008 for the 2009 MATE ROV Competition. The team ran until 2012, when the team leaders decided to instead join the more Computer Science oriented Intelligent Ground Vehicle Competition (IGVC). In 2014, the team leaders graduated and the team disbanded.

The team officially restarted in January 2015, with a one-and-a-half-year plan to re-enter the 2016 MATE ROV competition.

II. Long-term plan

Since the Dal TigerSharks are a new company with little experience, establishing a long-term plan early on was essential. The team was founded with an important goal: to develop an ecosystem of learning which would keep everyone engaged. This goal had five components:

1. Letting new members contribute
2. Providing a learning environment
3. Engaging all members in an impactful way
4. Learning by doing
5. Encouraging constructive criticism

The first step towards this goal was to ensure that the older members didn’t take over all the work. This was achieved with a large amount of newcomers from both Engineering and Computer Science backgrounds. They were pushed to pick a sub team of their choice and contribute to the best of their ability.

The second step was to hold tutorials for interested members to develop their skills. This goal was mostly realized. There was metal shop safety training so that students could use the metal shop. There were also a couple of student-led tutorials – one on using SolidWorks CAD software, and one on how to properly consider the cost and machinability of parts. There were also several group teaching moments during general meetings, such as mini-lectures about basic ROV mechanics such as buoyancy and thrust, and on how to engage in design-thinking through brainstorming & selection matrices.

The third step was to make all members feel engaged and important. This was done by ensuring that all members could have an impact on the team’s direction, if they chose. This was naturally accomplished by the chosen team meeting format. Every week, a full-team meeting was held. During this meeting, a member from each team would present what the team had accomplished in the past week, and the goals for the coming week. They also asked for feedback and ideas. This provided ample opportunity for any member to directly discuss and affect the direction of the team. An excellent example of this was during the chassis design phase, which will be discussed in Section B- III.

The fourth and most important step was to implement a team mantra of learning by doing. This simply means: if you don't know how to do something, you must know how to know how to do it. This was crucial for three reasons:

1. Few people on the team knew what they were doing in the first place
2. This is a crucial skill for being a top performer not only in the engineering industry, but everywhere in life
3. This skill allows for rapid growth in a minimal amount of time

This skill was encouraged by a very simple method: every time a team member asked a team leader a question about how to do something, the leader was encouraged to respond by asking the member to formulate on the spot a method of obtaining that information, or what the recommendation of the member was.

The fifth step was to encourage constructive conflict. In order to learn and come up with the best solutions, people need to seek the truth. This means more than just putting aside one's ego and listening to others. It is essential for an engineer to stand up for his/her own ideas until fully convinced otherwise. If this doesn't happen, the team member will retain a lingering doubt and resentment throughout the project. The only way to avoid this is to fully convince the team member of a better solution, a process which will grow everyone involved. It is likewise critical that every team member is comfortable to politely and calmly critique the ideas of anyone on the team, including team leaders. This year, this was implemented by holding design reviews and brainstorming meetings for key aspects of the project, such as the tools and chassis design. These sessions included presenting solutions and were concluded when the team agreed on a path forward. Though a few of these sessions were team wide to include interdisciplinary feedback, many of them were held within the individual sub-teams. Next year, this could be reinforced by including more meetings earlier on in the design process and have them include the entire team rather than a single sub-team.

It was determined important to have this extra time, since the team was completely re-building from scratch - none of the members had any experience with underwater vehicles, and very few had experience with robotics.

III. Team organization

Throughout the year, company employment ranged from 12-40 students. These students were broken up into six sub-teams: Chassis, Electrical, Tools, Thrusters, Waterproof Enclosures, and Business. Each Sub-team was assigned a team leader. The leaders were charged with being the focal point of their sub-teams. This meant delegating tasks and keeping everyone on track. The leaders would then meet weekly to discuss high-level team strategy, important milestones, and general team direction.

The entire team would also meet in the shop every week. A member from each sub-team would present the team's progress, as well as the plan for the following week. Then any group discussions/tutorials would be held. These weekly meetings helped to connect and engage the whole team.

Several apps were used to help organize the team and keep information flowing. The most important of these was Slack: a messaging app allowing for the creation of groups. Groups were created for each sub-team, for the leaders, and for general thoughts. This app served as the backbone of communication for the team.

Almost as crucial was OneNote: Microsoft’s cloud-based note-taking system. This allowed everyone on the team access to the same notes, which would auto-sync. This proved especially valuable during team meetings, since the leadership would write down the important points to hit before the meeting, and would fill in any additional discussion during the meeting for everyone to reference after.

C. Design Rationale

I. Design Requirements

The TigerSharks team began the design process by determining a list of Primary Requirements, which were essential to mission success, and Secondary Requirements, which were requirements to be fulfilled if possible.

The competition has several unique design requirements. The pool is 40 ft deep, much deeper than the 16 ft pool in the 2015 competition. This meant that we needed to prioritize two aspects of our design: waterproofing at depth, and vertical speed. As the ROV needed to be designed to fly on a rocket to Europa, it had size and weight limitations. Not only could the robot not exceed 85 cm in diameter and _ in weight. Bonus points were given for additional size & weight reduction. The biggest possible bonus was +20 points for a robot of less than 58 cm in diameter, and +20 points for a robot weighing less than 17kg. Since the size restriction was purely an engineering design challenge, it was decided that it would be unacceptable to not get these points. For the weight restriction, it was decided to design everything with weight as a top priority, to allow the best chance of receiving the bonus points. It is easier to make the robot light and weight it down later if it is too buoyant, than the other way around. The requirements were then used to define the important characteristics of the ROV. A list of these was made, along with a path forward to achieving the characteristics. Finally, these characteristics were ranked in order of importance. The requirements and characteristics are summarized in *Table 1* below.

Table 1: Important Characteristics

Primary Requirements	Secondary Requirements	Ranked list of characteristics	How to achieve characteristic
Survive 40 feet underwater	Tilt in all directions	1. Survives	- Watertight - Enclosure - Connectors - Corrosion-resistant - Slightly positively buoyant
Move underwater: - Fast vertical motion - Strafe horizontally - Spin on the spot - Controlled from the surface	Stability control	2. Maneuverability & Stability	- Strafing - Vectored thrusters - Light materials - Responsive controls - Low center of gravity - High center of buoyancy

Diameter <58 cm	Inexpensive	3. Size & Weight	- Light materials
Weight < 22 kg	Weight < 17 kg	4. Speed/Acceleration	- Light materials
Neutral or slightly positive buoyancy		5. Clear Data & Video	- Quality components
Safe to operate and launch by hand		7. Reliability	- Quality components - Back-up components
Include the necessary sensors: - Camera - Pressure sensor - Temperature sensor		8. Cost	- Engineering design - Inexpensive materials
		9. Aesthetics	- Paint - Logos

This gave the team a clear path through which to focus their energy.

II. General Design

To being the initial stage before any competition details became available we started with a general robot design made out of PVC pipe to test thrusters, electrical and tools. The structure was of square design and was used once to test the thrusters and electrical. The square design was extremely buoyant and needed weights to make it more neutral. Once the competition details were released a new design was needed.

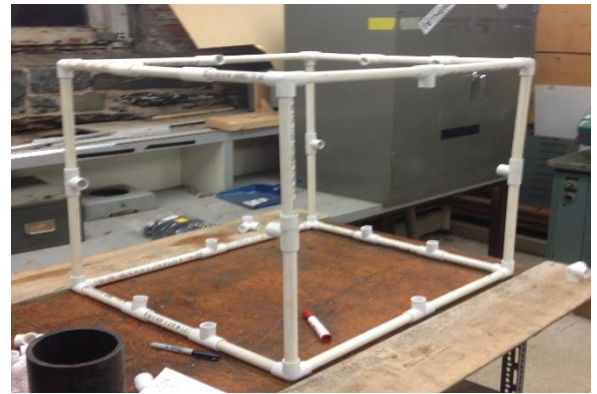

Figure 1- PVC Frame

It was important to determine an initial general design direction as a team before designing specific sub-systems. This was a loose design, as not only was it recognized that things would change as the other systems were fleshed out, but our clients had not yet revealed their final needs. This meant that the team had a general overview of the required tasks, but did not yet know the specifics. The design process went as follows:

First, the team members were encouraged to brainstorm for a week on their own or in groups. The next week, team members who had come up with designs presented them to the team. All designs received feedback, and were compared to the design requirements outlined in the previous meeting.

A final design was made in CAD with approximate dimensions of the thrusters and waterproof enclosure. It was designed to fit within the 58cm diameter size restriction. The key characteristic of this design was the oval plate. Since the design was size-limited by the diameter, it made sense to begin with a circle for the design to maximize working area. Speed is required for forward/backward movement, whereas precise movements are required for strafing. It therefore made sense to pinch the circle into an ellipse, so that the ROV would be more hydrodynamic in the forward/back direction, and less so in the side/side direction. It was also decided that once the design was fully fleshed out, as much area would be removed from the top plate as possible, in order to reduce weight and drag when travelling in the vertical direction.

The thruster configuration has four vertical thrusters, and a vectored configuration for all other motion. The vectored configuration is standard for work-class ROV's, and will be discussed further in the "Thrusters" section.

III. Chassis

The chassis serves two main functions: providing the main structure and providing the approximate amount of buoyancy to keep the robot stable. Material selection was important, since water adversely affects many materials. For example, wood was immediately discarded as a building material, since the dimensions and material properties of wood change when wet. Corrosion-resistance was a concern and preference was given to materials that would not corrode under water.

The biggest factors when selecting materials were, in order of importance:

1. Function
2. Machinability
3. Weight
4. Cost

The materials needed to be strong enough to survive transportation and operation. Operational loads are lower due to buoyancy in water and therefore less important. Machinability was paramount - because of the inexperience of the team, it was important to be able to make parts quickly and easily. It was also important that most, if not all parts could be made at the Dalhousie facilities, whether the ROV shop, the metal shop, or the woodworking shop. Machinability also ties into price in the real world. The easier it is to machine a material, the cheaper it is. This only applied to outsourced parts for us, since the ROV team does not pay salary to its employees. Weight was important not only to try and get full bonus points for the weight restriction, but also because a lighter ROV will accelerate quicker, and thus perform better.

HDPE (High Density Polyethylene) was chosen as the material for the top plate. This is because HDPE has a density (970 kg/m³) that is very close to fresh water (1000 kg/m³). Also as a plastic, it is incredibly easy to machine, as seen in *Table 2* below.

Table 2: Material Information

Material	Cost	per	Density	Machinability (relative to Aluminum)
Plastic (HDPE)	\$ 3.30	kg	1450	0.5
Steel	\$ 2.25	kg	7850	3
Titanium	\$ 22.00	kg	4500	3.65
Aluminum	\$ 4.20	kg	2712	1

The machinability table approximates how much it costs to machine a material relative to the cost of machining aluminum, which is a soft metal and thus easy to machine. HDPE also has the added benefits of being inexpensive and of not being damaged by water.



Figure 2- Skids & Frame

The skids are made out of aluminum for similar reasons. Aluminum is light and easy to machine for a metal. Aluminum effectively protects itself from corrosion by forming an oxide layer on its surface. Aluminum was chosen instead of HDPE for the skids because aluminum is stronger, and therefore less thickness is required to make an effective support structure as seen in *Figure 3*. This means less buoyancy force coming from the skids, which is good for two reasons: we anticipated the robot being too buoyant and requiring to be weighted down after construction, and it is not desirable to have large buoyancy forces near the bottom of the ROV. Finally, it is even easier to buy stock L-brackets, drill holes and bolt them together than it is to machine plastic.

IV. Buoyancy

Buoyancy is one of the most important considerations when designing an ROV, and it is strongly intertwined with the chassis design. An ROV can have one of 4 types of buoyancy: positive, negative, neutral, and active. Most small ROV's are either neutrally or slightly positively buoyant. Neutral buoyancy means that without thruster input, the ROV will stay in place. This makes the ROV very easy to control. Adding a slight positive buoyancy gives an intrinsic safety mechanism for minimal loss of control: if anything happens to the ROV, it will slowly float itself up to the surface. Negative buoyancy is only used for bottom-crawlers – ROV's which spend most of their time on the bottom of the ocean. Active buoyancy systems are more complex, and mostly used in submarines. In these systems, ballast tanks fill with either water or air, changing the buoyancy of the craft to assist with ascent and descent.

The buoyancy equation is: $B = \rho_f V_{disp} g$, where ρ is the density of the fluid, V is the volume of fluid displaced by the body, and g is the acceleration due to gravity. V is the only element that can be controlled, and so careful thought must be put into not only how much volume is displaced, but where it is displaced. This is because the Center of Buoyancy (CB) is found at the centroid of the displaced fluid. The CB is where the buoyancy force can be represented as acting on the body. If the CB and the Center of Gravity (CG) of the ROV are in the same location, the ROV will be able to spin freely about its axis in any direction. This is often undesirable, because stability is required to pilot an ROV with ease. If the CG is above the CB, and the ROV is tilted in any direction, the ROV is unstable: the CG and CB will create an overturning moment, as seen in Fig. 4, which will incite the ROV to flip upside-down. This is undesirable for obvious reasons.

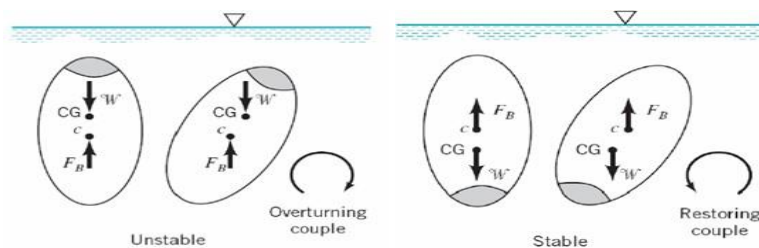

Figure 3- Depiction of righting moment underwater, Image from <http://slideplayer.com/slide/8427378/>

If the CB is above the CG, and the ROV is tilted in any direction, the ROV is stable: the moment created will work to automatically self-right the ROV, as seen in Fig. above. The greater the distance and force

between the CB and CG, the greater this righting-moment will be. ROV elements which contribute mostly to the CB due to their high volume and low density are called floatation. Elements which mostly contribute to the CG due to their high weight and low volume (high density) are called ballast. It is therefore important to put most of the floatation as high as possible on the ROV, and most of the ballast as low as possible.

For this reason, we put the waterproof enclosure and the top mounting plate at the top of the ROV, and all the tools at the bottom, attached to the heavier skids. These elements acted as passive buoyancy: buoyancy elements which do not change over the course of the ROV’s mission. At the beginning of the ROV’s construction, the final mission details were not known, and thus the final weight and buoyancy of the ROV could not be calculated. It was thus decided to construct these passive buoyancy systems to be as light and as far apart as possible – more floatation or ballast could be added at the end to tweak the balancing of the ROV.

In addition to passive buoyancy, it was initially considered to use a simplified version of active buoyancy, since the 40 ft depth of the pool, the number of missions the required bringing objects to the surface, and the time limit/bonus, meant that having quick vertical movement would be essential. The system would have comprised of two symmetrically-located tanks which would fill with water, or push it out using compressed air. It was however always understood that this system would be complex to build, higher mass, and probably not worth the effort. This system was not attempted because of limited of time.

D. Thrusters

I. Thruster Configuration

As mentioned previously, the most common thruster configuration for working-class ROV’s is the vectored configuration, shown below in Fig. 5.

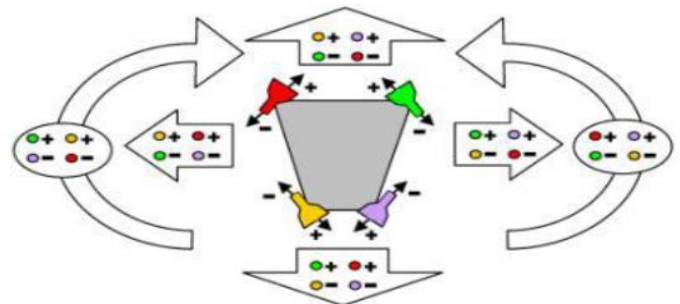

Figure 4- Vector Configuration, image from Dal ROV 2012 report

This configuration allows for strafing in any horizontal direction. This is critical, because it allows the ROV to make fine adjustments to align its tools with mission objectives. This was the configuration that the old Dalhousie ROV team, the Dalhousie Privateers, had always used. However, it was posited at the beginning of the year whether a full, three-dimensional vectored configuration would be better. Instead of having 4 vectored thrusters for horizontal movement, and 4 vertical thrusters for vertical movement, all 8 thrusters would be vectored. Imagining the ROV as a cube, the configuration would have a thruster at each corner, angled so that it could provide thrust in all planes of motion, as shown in Fig. 6.

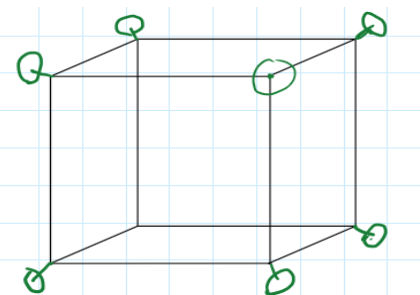

Figure 5- Cube Thruster Configuration

An Excel spreadsheet was created to empirically determine which thruster configuration would be the best. The spreadsheet compared how well four thruster configurations performed when travelling in a given direction. The spreadsheet used the amount of thrust from a Blue

Robotics T100 thruster, combined with trigonometry to calculate the forwards and sideways thrust of each configuration, as well as the forwards and sideways acceleration. The acceleration did not factor in the drag of the water, and was thus simply a relative acceleration used to compare the relative effectiveness of each thruster configuration. The configurations tested were: two thrusters pointing in the same direction, four thrusters pointing in the same direction, a traditional 4-vector thruster configuration, and the proposed 8-vector thruster configuration. The results were very clear: a vectored configuration is always the best use of the number of thrusters in an ROV.

For example, using two thrusters for forward-reverse motion and two for side-side motion yields a thrust of 46 Newtons (N) forward and 36 N backward (the thrusters are more powerful going forwards than backwards due to the shape of the propeller and cowling). Using four thrusters in a vectored configuration with the thrusters at a 45-degree angle, however, yields a thrust of 58 N in any direction. This is because in the former, only two thrusters are helping, while in the latter, all four thrusters are either pushing or pulling the craft.

Additionally, the vectored configuration does not need to be at a 45 degree angle. A lot of forward/reverse acceleration is needed to help the ROV traverse long distances and stop on a dime, but little acceleration is needed for side-side movements, where only slow, precision maneuvers are desired. This means that the thrusters can be angled to provide more thrust in the forward-reverse direction, and less sideways. For example, with an angle of 30 degrees, the thrusters provide 71 N of forwards/reverse thrust, and 41 N sideways.

Similar calculations were performed for an 8-vector configuration and for four thrusters pointing in each direction (which is unrealistic, because 12 thrusters would then be needed, an additional four for up/down movement). A visual of the angles used in the 8-vector calculations is shown in *Fig. 7*. The results of all calculations are summarized below in *Table 3*.

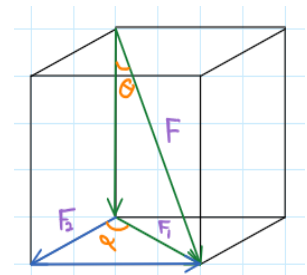

Figure 6- Calculations for 8-Vectored Configuration

Table 3: Thruster Calculations

Configuration	ROV Mass (kg)	Ffor per thruster (N)	Frev per thruster (N)	Theta (degrees)	Alpha (degrees)	Forward Thrust (N)	Reverse Thrust (N)
2-straight	20	23.1	17.8	N/A	N/A	46.3	35.7
4-straight	20	23.1	17.8	N/A	N/A	92.6	71.4
4-vector	20	23.1	17.8	45	N/A	58.0	58.0
4-vector	20	23.1	17.8	30	N/A	71.0	41.0
8-vector	20	23.1	17.8	45	45	82.0	82.0
8-vector	20	23.1	17.8	30	45	100.4	58.0

It is important to note that even though having four straight thrusters provides more forward thrust than having an 8-vector configuration at 45 degrees, it provides less reverse thrust, meaning that these configurations are approximately equivalent thrust-wise. However, the 4-straight configuration is only acceptable for up/down movement, since it doesn't allow for strafing.

The two configurations being debated became the 8-vector configuration, and the 4-vector with 4-straight for up/down movement. The calculations show that the optimal thrust configuration is the 8-vector configuration, since it provides equivalent up/down thrust, but provides superior horizontal movement.

The major drawback with the 8-vector is that it would be much more complicated to program the link between joystick input and which thrusters would fire. As a new company, it was decided to use the simpler 4-vector configuration, and to try the 8-vector next year once we have more experience.

II. Thruster Design

Figure 8 shows an exploded view of the designed thruster. It consists of a duct, a propeller, a motor, a rear arm, and a cone. The Blue Robotics M100 motor was used as an actuator since the motor had the waterproof ability so that additional waterproofing was not required. The mounting holes on the front and the back were useful to apply the team's custom design. The Blue Robotics T100 propeller was used as the team's custom design propellers broke easily. Furthermore, they produce a 20% lower thrust than the T100. The cones and the rear arm were hollowed out to reduce material, thereby reducing weight and cost as well.

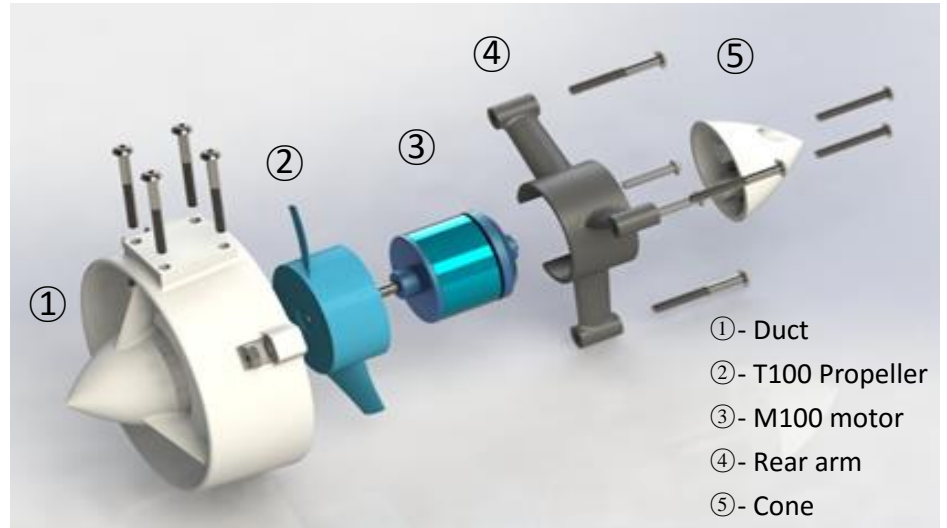

Figure 7- Exploded view of Team Designed Thruster

The duct was designed and built out of ABS plastic using the Dimension 1200es 3D printer. The design rationale behind applying the Wageningen No. 36 form on the duct wall was to give it a bidirectional capability as illustrated in Figure 8. This resulted in balanced thrusts for forward, backward, and lateral motion. There are three mounting blocks on the outside wall to connect the rear arm. #6-32 stainless steel nuts and bolts were used to prevent corrosion. On the top of the duct, there is a mounting block with four #6-32 holes to connect the thrusters to the body frame using nuts and bolts as well. The front nose, arms, and the wall are printed together as one piece to avoid adding an extra mounting system.

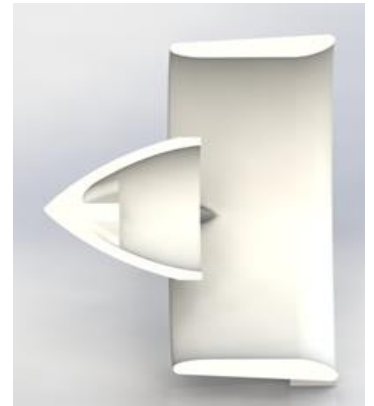

Figure 8- Cross-sectional of Duct

The rear arm and the cone were 3D printed as well. The four holes in the rear arm and the two holes in the cone were designed to mount them into the motor threads on the back using M3 stainless steel bolts. The shape of the arms and cones are designed hydro dynamically, to minimize drag. Drag coefficient of a cone is only 0.5.

III. Performance

Thrusts were measured through the designed test platform as shown in *Figure 9*. The thruster was mounted to a T-shaped aluminum bar using the mounting holes on the top and a force gage was hooked onto the bar. The bar was supported by an aluminum rod which itself was inserted through two holes (one on either side of the tank wall) and the hole in the bar. As it acted as a pivot, thrust made the aluminum bar swing and it pulled on the force gage. Depending on thrust strengths, the angle of the aluminum bar was adjusted to 90 degrees with respect to the ground by pulling the force gage by hand.



Figure 9- Thrust Test Platform of side and top views

Because the distances from the thruster and the hook to the pivot point were not identical, the converting factor 0.212 was multiplied to the measured values. According to the experiment, the maximum thrust, 28.3 N, occurred at 16 V. *Figure 10* shows the experiment result at the operating 12 V. As expected, thrust in the forward direction was higher than the reverse direction because the area of the front inlet was greater than the back. The maximum thrusts were 17.9 N at 9.5 A and 13.2 N at 9.8 A in the forward and reverse directions, respectively.

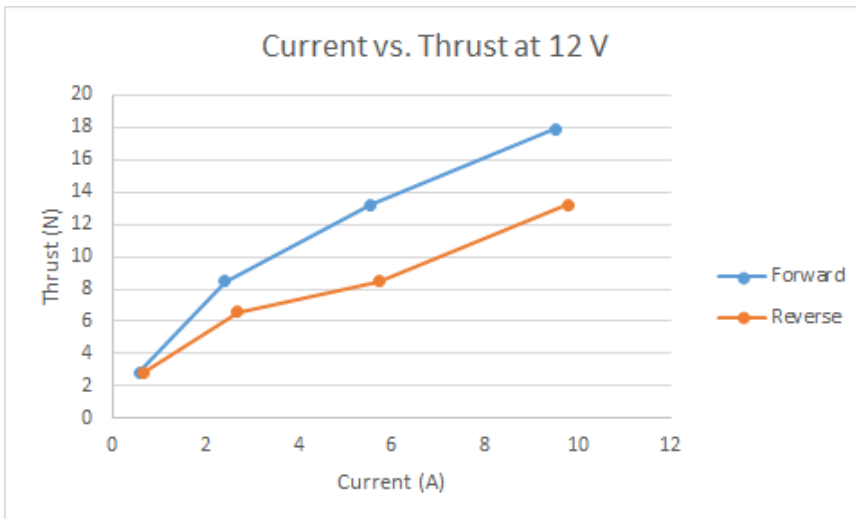

Figure 10- Current VS. Thrust at 12V

Under full load, one thruster uses 114 W at 9.5 A and 12 V. When all thrusters are activated, 240 W is used in total as the dc to dc converter has 20 A capacity

E. Waterproof Enclosure

The design of the onboard electronics enclosure was driven by a desire to use custom and non-permanent electronic connections for all the payload tools, cameras and sensors. This emphasis on using non-commercial parts was established due to several key advantages that custom connectors offer. Firstly, they cost much less than any commercial IP69-rated connectors. Especially with a depth requirement upward of 40ft depth, the commercial connectors suited to our need were found to be either insufficient in terms of their depth rating, or were excessively robust and expensive (usually intended for open-ocean and long-term use). Using a custom design and fabricating the connectors in-house avoided excessive costs without having to compromise on the reliability of the connectors. Another benefit that this offered was that the part could be designed to exactly meet the required criteria as opposed to the team having to settle for a connector with a number of pins, current rating and/or mounting dimension dictated by what was available on the market.



Figure 11- Enclosure Sealed View

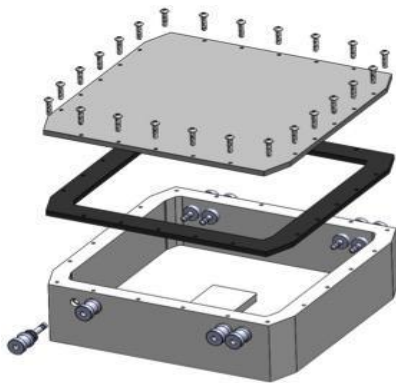

Figure 12- Enclosure Exploded View

To accommodate the connectors that were designed, the enclosure required a thick wall for the double internal o-ring seals and enough external flat mounting area to provide space for all 15 connectors. The enclosure also required sufficient internal volume to easily hold all required electronics and needed to be design in a way that would reduce the number of potential leak points as much as possible. To meet all this criteria, the enclosure was machined out of a single 2"x12"x12" block of HDPE with a plate of 1/8" aluminum to serve as the lid. To seal these two parts, a rubber gasket was cut from 40 durometer rubber and 22 screws thread directly into the enclosure body to provide an even and tight compression. *Figure 11* is a rendering of the enclosure assembly showing how the enclosure would properly seal. *Figure 12* is an exploded view to demonstrate each of the key elements of the enclosure.

F. Electrical Systems

In order to survive underwater and be able to complete the tasks, the ROV electrical system contains 7 systems list below.

- I. Power supply system
- II. Onboard Processor
- III. Tether
- IV. Video
- V. Sensor
- VI. Pilot System
- VII. Tools Control System

Onboard Processor is optional but it gives a lot of advantage. With an onboard processor, digital communication is possible and there is no need to send analog signal through tether which can be interfered by the power cable. It also reduces the complexity of the hardware and uses fewer cables on tether for communication.

I. Power Supply System

The power supply is 48V on poolside. All electronics are not designed to work with 48V directly so voltage converting is required. With higher voltage through the tether, the power loss is smaller so the dc converting must be done on the ROV side. Most electronics are running under 12V and 5V so two power supply voltage will be needed on the ROV. The power supply system is also separate into two sub-systems, subsystem I (for the pilot motor) and subsystem II (for camera and sensors) so that the high current load on pilot motor does not affect all the sensors and camera, the whole DC converting system is divided into two separate sub-systems.

i. Power supply subsystem I

In this subsystem, only 12V output is need because all piloting motors are designed to work under 12V. The 48V to 12V dc to dc convertor used in ROV are NQB-468NMA-ANH (102-2671-ND) produced by CUI Inc. This DC converter is able to handle 39A. The ROV have a maximum output current of 36A for pilot motors. Motor will require more current when it jumps from zero speed to full speed. In order to meet the requirement of the current at the instant of jumping to full speed, two dc to dc converter are connected in parallel to separate the current load. The minimum input voltage for this DC convertor is 36 V so that the max input current is around 20 A because of voltage drop over tether. Output 36 A will require 9 A input current so that this system should be fine.

ii. Power supply system II

In this subsystem, both 5V and 12V are required. The camera requires 12V and the processor and sensors require 5V. Some sensor requires lower than 5V which can be provided from the built-in regulator in processor. The 48V power supply go through a 48V to 12V DC PYB30-Q48-S12-U converter produced by CUI Inc. This output is connected to camera and a 5V regulator (LM2595). Processor and sensors doesn't require high power so a regulator is enough.

II. Onboard processor

There are three choices for the on board processor, PIC, Arduino and Raspberry Pi. The advantage and disadvantage are list in *Table 4*. The final decision for onboard processor is Raspberry PI 2B. PI is selected because of its advantage that can't be provided by PIC and Arduino. It's easier to add new functions to the ROV on programming side because it supports multitask. The operating system running on PI is Ubuntu 14.04. With the OS, PI is able to communicate to the Linux laptop on ground over Ethernet. All the command, sensors data and video data can be sent over Ethernet. Since everything is on Ethernet, the hardware on dry side is simpler, a laptop and a router is enough. It also gives a wide range of choice of sensors since it supports a lot of standard communication protocols such as SPI, I2C, UART. The

disadvantage of PI can be resolved through Adafruit 12bit PWM while PIC and Arduino disadvantage are more difficult to overcome.

Table 4: Advantages and Disadvantages for microcontrollers

Microcontroller	Advantage	Disadvantage
PIC	<ul style="list-style-type: none"> Cheap 8bit pwm without extra components 	<ul style="list-style-type: none"> Only 4 PWM outputs (need 6 to control motors plus 2 for claw motor controls) Not capable of streaming camera feeds. No support for ethernet communication
Arduino	<ul style="list-style-type: none"> Servo library for easy pwm control Shield for ethernet communication Capable of 12 PWM outputs Capable of analog input 	<ul style="list-style-type: none"> Not capable of streaming camera feeds Ethernet shield uses output pins, reducing number of available PWM outputs to 8
Raspberry Pi	<ul style="list-style-type: none"> Onboard ethernet control 26 GPIO pins SD card storage, Linux Operating System Multitask 	<ul style="list-style-type: none"> Only 1 hardware PWM output, software pwm could only output in increments of 100us (25% motor control).

III. Tether

The tether used is 24.38 meter long tether produced by VideoRay LLC which contains 3 twisted pairs of signal line (28-gauge twisted pairs) and 2 pairs of power line(18-gauge wires). The tether itself is neutrally buoyant. The communication between ground computer and onboard processor is ethernet connection which only use 2 pairs of the signal line. This tether is designed to transmit video data which means it has enough bandwidth for video data.

IV. Video

The are two cameras on the ROV, Delta Vision Splash Cams and Panvigor® underwater cameras. Both cameras are left from previous team (The Dalhousie Privateers 2012). Both camera are analog waterproof camera and no extra waterproof enclosures are needed. There are built-in lights in both cameras which makes the performance better in light less environment (40-foot underwater). Since PI doesn't have any analog input at all, all video data is converted into digital data by Video DVR and import to the onboard processor. Then, the data is streamed over Ethernet to laptop on ground. No analog monitor is required on the ground.

V. Sensors

According to the task, two sensors are required for the task, pressure sensors and temperature sensor. As mentioned before, the power supply subsystem I will shut down when the current reach 20A. There will be a current sensor to detect the current through tether.

i. Pressure

The task requires ability to measure depth by measuring pressure underwater with accuracy of 10cm. The depths should be given in meters, at least to the hundredths place. The pressure sensors accuracy need to be around 1 kPa. The sensor used on ROV is MS5540C Miniature Barometer Module with resolution of 10Pa This Module has a 16 bit ADC built-in and it uses SPI protocol so that no external hardware is needed to communicate with PI. No extra waterproof is needed and the size is small which make this module a perfect match for this mission.

ii. Temperature

The task requires the temperature measurement with accuracy of 2 degree Celsius. The sensor used is DS18B20 provided by MAXIM with resolution of 0.5 degree Celsius in the range of -10 degree Celsius to 85 degree Celsius. It provides digital output with just 1 wire with communication which is compatible with PI.

iii. Current

One analog current sensor ACS713 is used onboard with LM311 comparator. ACS713 is a Fully Integrated, Hall Effect-Based Linear Current Sensor. Since PI can only accept digital input, LM311 comparator is used. When the current is below 20A, LM311 output 0V. When the current limit(20A) is detected, LM311 will output 3V signal to PI.

VI. Pilot system

Pilot system has three parts: motor driver, PWM driver and the Xbox controller. Motor driver and PWM driver are necessary part on the ROV. The pilot will use Xbox controller on ground to control the ROV.

i. Motor driver

With the size restriction, it's better to choose the commercial product instead of building a motor driver. The commercial product can be highly integrated and also has reliable performance. The motor driver used in ROV is Afro ESC 30A pre-programmed bi-directional ESC from Blue Robotics. It also has build-in backward current protection. The PWM signal range is from 1100us to 1900us. 1500us is the stop signal. 1500us to 1900us are forward and 1100us to 1500us are backward.

ii. PWM driver

The ROV requires 8 PWM signal in order to control 6 piloting motors and 2 claw motor but PI only has one channel build-in hardware PWM. If software PWM output are used, it will be hard to have precision control. The library used, wiring Pi, has resolution of 100us which means the minimum output is 25% on software PWM. In order to get precision, the Adafruit PCA9685 16-channel 12-bit PWM driver is used. The PWM driver use I2C communication protocol and it can achieve resolution about 0.77us at 315Hz.

iii. Xbox controller

The ground station uses Xbox 360 controller as the main controller instead of using keyboard. It will be easier for the pilot. There are 5 axes and 11 buttons on the Xbox controller can be used for piloting the ROV.

VII. Tools control circuits

Based on the tool decision, there will be 2 motors used for 2 claws. On electrical side, 2 motor driver are needed. The motor used for claw doesn't require big current and the team has built two identical motor driver for the tool control circuits. The control circuits are two bi-directional motor driver with a built-in backward protection resistor. The circuits are designed to have a maximum current of 1A which is just enough to turn on the motor and preventing from overloading. As shown in *Figure 14* (enlarged view in Appendix I, II.).

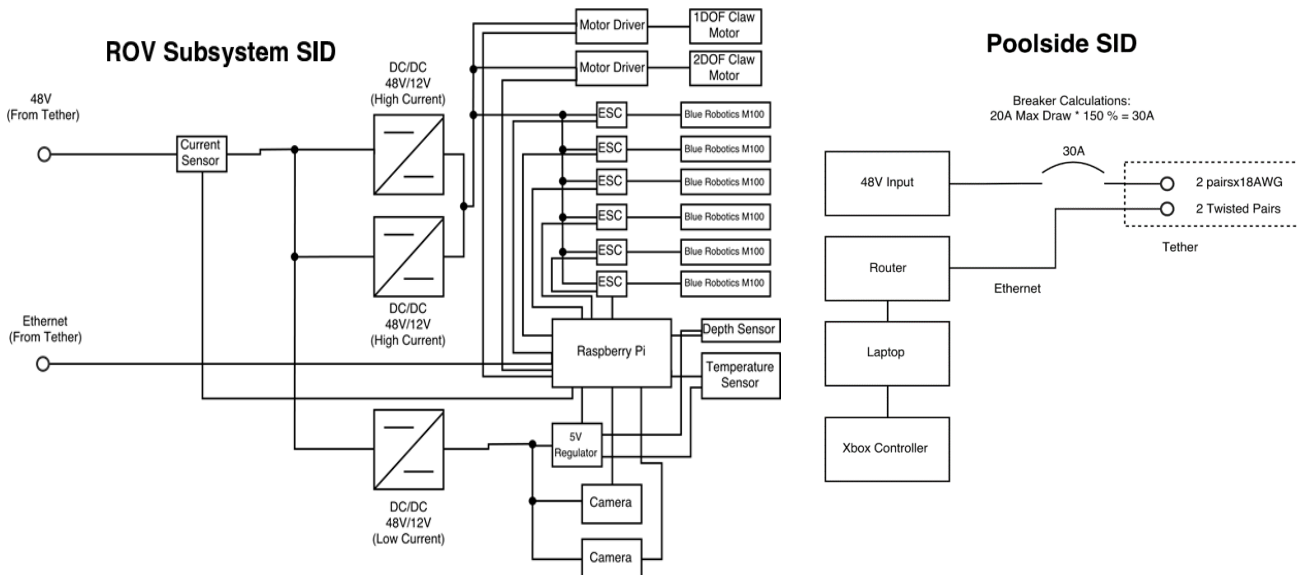

Figure 13- System Interconnection Diagrams

G. Tools

I. General Rational

The final part of the ROV to be considered was the tools, since the requirements were only revealed late in the design process. The first step here was to comb through the list of tasks and extract key pieces of information: what kind of tool(s) could be used, and where on the ROV would the tool(s) have to be placed.

The list of tools included a claw, a collection basket, a rotary sweeper to sweep objects into the collection basket, a tool that opened and closed like a drill chuck to collect items from the bottom of the ROV, a pressure sensor, a temperature sensor, a hook to open doors, a flipper that would use a single motor and a spring to scoop up a CubeSat and flip it into a collection basket, and a camera. A camera, a pressure sensor,

and a temperature sensor were absolute necessities required by the competition, however it was found that otherwise every single task could be performed using a claw in the bottom-front of the ROV and a hook to open doors with. The claw would need to grip and rotate on its axis to flip a CubeSat. While one claw is good, two would be better - this way the robot could carry two things at the same time. Only one claw would need to rotate, the other could simply be a gripper.

II. Payload Tools

To properly equip the ROV for the mission it was determined that striking a balance between tool multi-functionality, reliability and performance were key design requirements. An iterative 3-stage design process involving prototyping, testing and tool refinement was implemented to establish the most effective means of completing the mission tasks. Through these tests, it was found that a gripper could be used to complete almost all the necessary tasks and that with a second gripper most of the tasks could be completed in a more efficient way. It was also determined that to orient the bolts (to be attached to the wellhead) and to flip the CubeSats. A rotating gripper would be greatly beneficial. To accommodate this need, one of the claws on the robot employs a second degree of freedom so that it can both grab and rotate a given object. Due to the challenges and added complexity that are presented in adding a second motor for rotation, the rotating claw was designed to both grab and rotate under the power of a single motor.

A friction clutch, held by four springs keeps the claw from rotating as the ACME thread is turned. This enables the claw to close tightly abiding the same mechanics as the simple claw. However, when the gripper is clamped tight and the rotating thread can no longer push the ACME nut forward, the resisting friction forces on the clutch plate will be broken and the claw will turn about the axis of the Acme thread. Once the claw is rotated to its desired position, the motor can be run in the opposite direction and the friction of the clutch will once again provide greater resistance than the travelling nut, allowing the gripper to release its grip without turning back in the opposite direction.

Figure 15 is the claw in both the open and closed positions. Figure 16 is a rendered section view of the claw. In this view, the two pieces highlighted in red and blue create the friction mate that drives this design.



Figure 14- Claw in Open & Closed Position

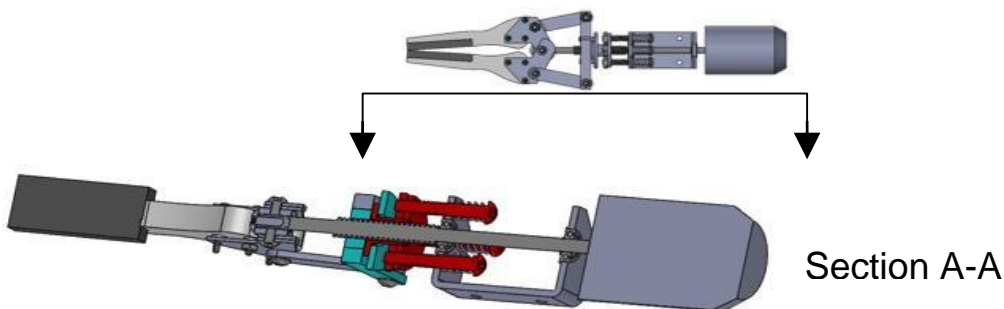

Figure 15- Cross section of claw

H. Conclusion

I. Overall outcome

To conclude, the Stingray was designed and built by a multidisciplinary team of engineers to withstand transport via spaceship from earth to Europa. It was rated to pressures below 40ft depth and has been proven to operate handily in the demanding underwater environments in which it's missions will take place. By promoting the use of custom-designed mechanisms and electrical systems on this ROV, the tasks were tackled in the most efficient way possible using tools and a configuration specific to the objectives of the mission. Equipped with two grippers, several cameras, temperature and pressure sensors as well as having the ability to travel in any direction while maintaining almost any orientation enables this ROV to complete the mission with concise motions and in a time sensitive way.

II. Learning experiences

Our experience as a company and a team was a rewarding one. One thing we learned was the true value of organization and open communication. We organized ourselves into individual sub-teams, each in charge of a different aspect of the project. This fractioning did initially cause some issues as far as communication was concerned. This was taken care of by weekly leader meetings in addition to the team meetings. In the former, leaders of each sub-team reported their progress. In addition, we also utilised Slack, a robust company communication software, which made our management significantly more efficient.

III. Future improvements

Future recommendations for this design include reducing the footprint area of the ROV to decrease the effective drag encountered during ascent and descent. This would greatly help speed up the mission as the vertical travel time becomes very significant when tasks must be completed at a depth of 40ft.

It is also recommended that the electronics enclosure be reduced in size to help limit the amount of ballast necessary to counteract its buoyancy. By reducing the overall mass of the ROV, the maneuverability and speed become more favorable and the mission can be completed faster.

Finally, the company would like to extend its sincere gratitude to both the MATE Center and Dalhousie University for their support of this project. The design and construction of this robot inspired growth and learning as well as a deeper appreciation for the unique challenges associated marine technology systems

Appendix

I. Safety check list

A. Electrical System and Connections

1. 30 Amp circuit breaker connected within 30cm of positive power supply terminal
2. Tether securely connected to positive and negative terminals
3. All topside electronics inside splash proof box
4. All splices within ROV covered with electrical tape or heat shrink
5. All electrical components in ROV secured to bottom
6. Clear communication when powering on ROV

B. Mechanical and Physical Systems

1. No sharp/jagged edges on ROV
2. Motors shrouded and clearly marked
3. All connectors potted and securely connected to ROV
4. Strain relief on tether connected to ROV
5. Tether securely fastened topside
6. Dangerous areas clearly marked with safety tape

C. Personnel

1. All team members have safety glasses on
2. Close toed shoes worn
3. No loose clothing or dangling jewelry/hair
4. Long pants worn

II. System Integration Diagram

Poolside SID

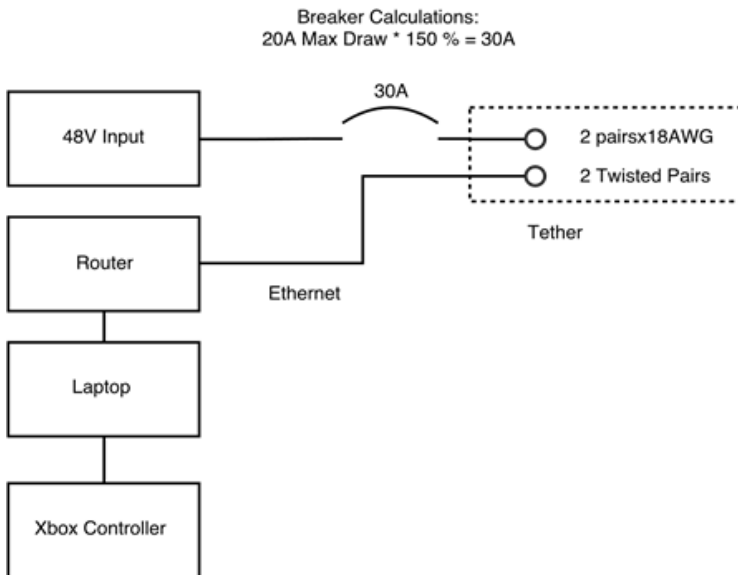

Figure 16- Enlarged View Poolside SID

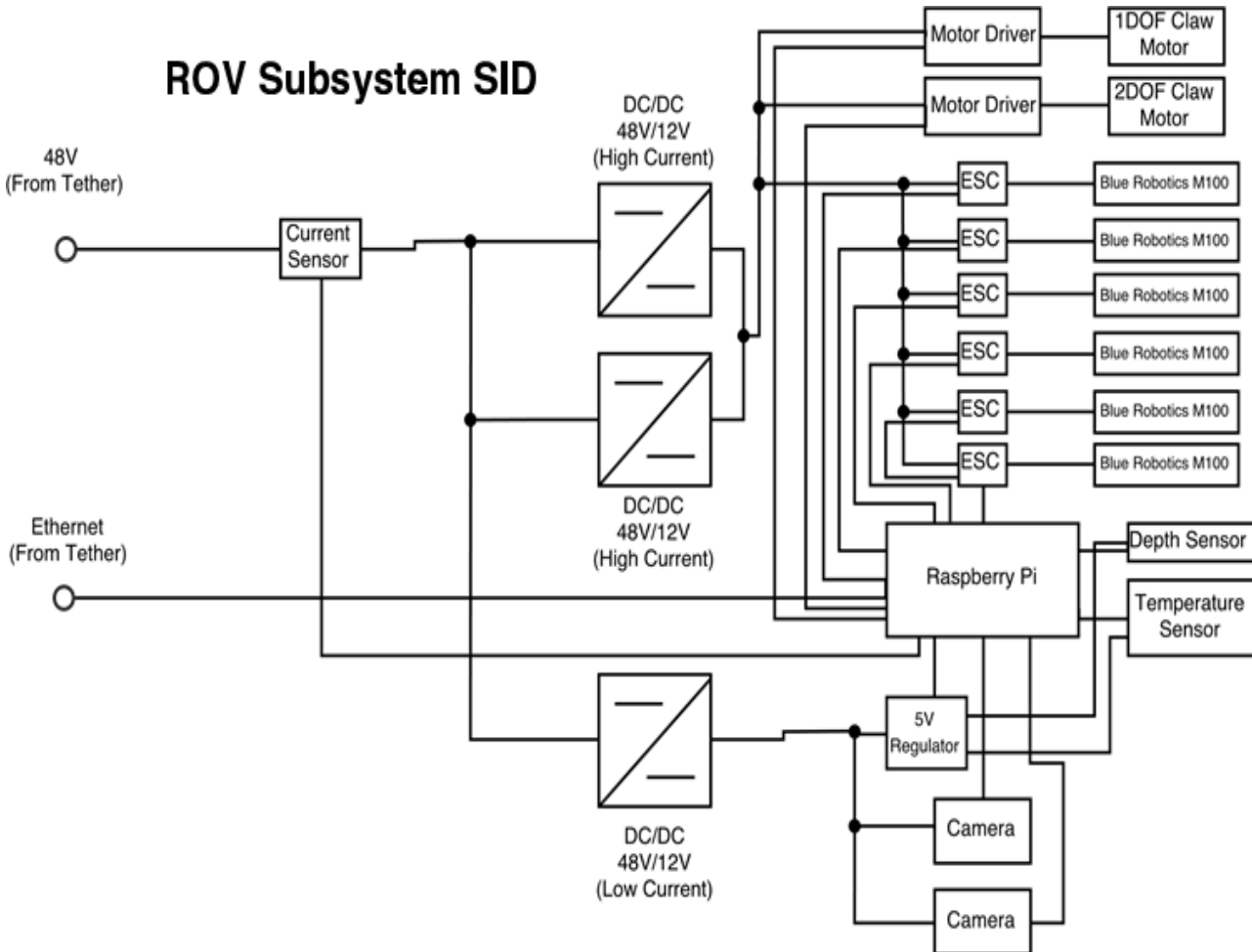

Figure 17- Enlarged ROV Subsystem SID

III. Final ROV Assembly Drawing

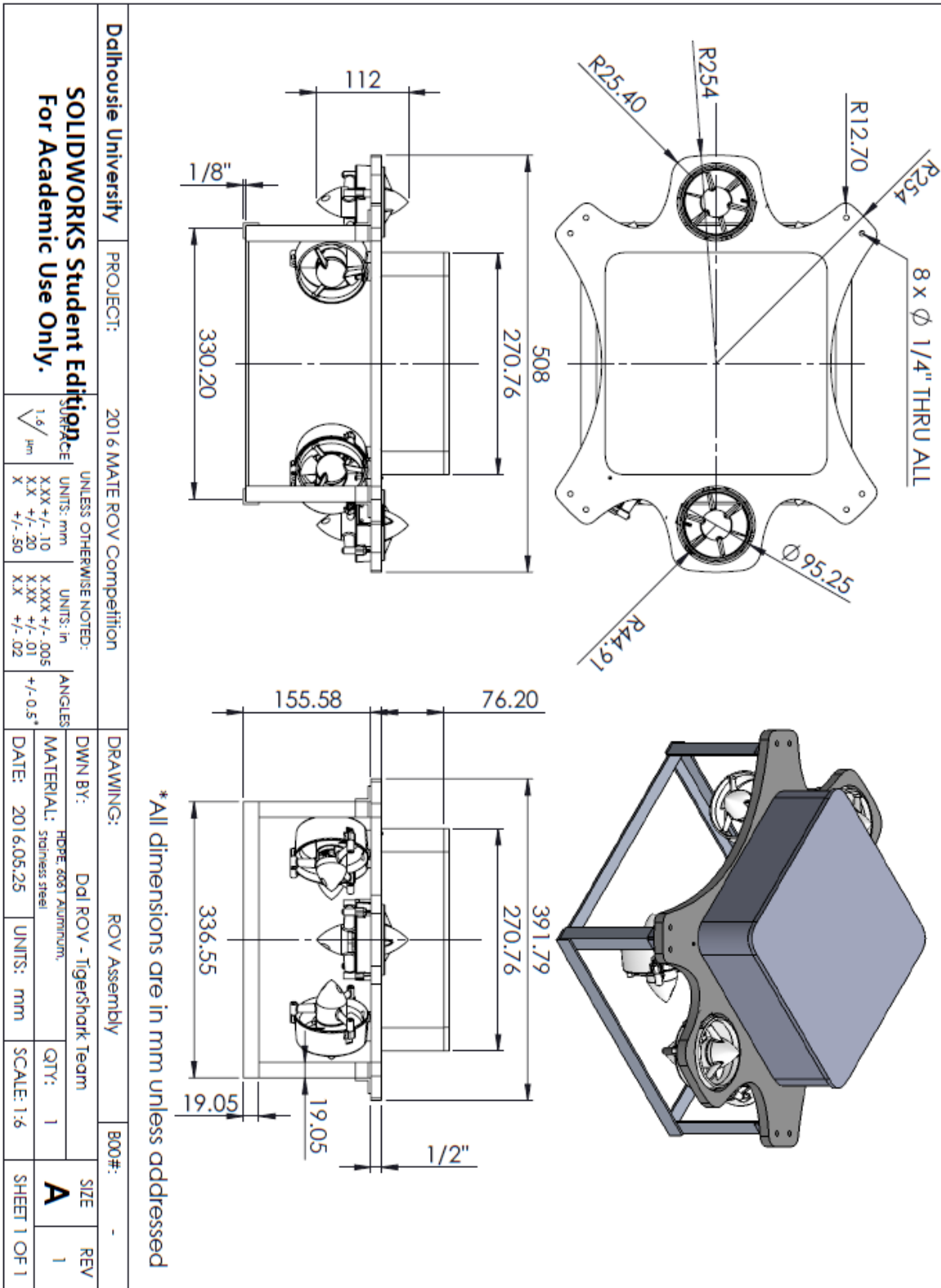

Figure 18- Final ROV assembly drawing

IV. Full budget breakdown

Table 5: Team Project expenditure and income

Expenditure			Income			
	Item	CAD		Item	CAD	
Thrusters	3D printing	268.72	Sponsors	Shell CAP team	4,000.00	
	Fasteners	20.68		Engineers Nova Scotia	600.00	
	Bluerobotics M100 motors	736.00		Ultra Electronics	500.00	
	3D printed body	201.60		Dalhousie University	6,000.00	
	Spare body	67.20		Subtotal	11,100.00	
	Hardware (nuts and bolts)	1.03		Other	Residual from previous years	1,000.00
	Bluerobotics T100 Propeller	36.00			Dalhousie SEEF Fund	2,500.00
	Subtotal	1,331.23			Subtotal	3,500.00
		Total	14,600.00			
Electrical	Ez cap Video USB dongle	74.42	Total (USD)	11,242.00		
	Deep cycle 12v battery	162.24				
	USB to Ethernet dongle	41.35				
	Tether	230.00				
	Lawn and Garden Batteries	367.95				
	Temperature Sensors	60.00				
	Raspberry PI kit	143.74				
	Raspberry PI board	80.38				
	Miscellaneous components	220.23				
	6x ESC	150.00				
	2x DC to DC convertor	238.60				
	Subtotal	1,768.91				
	Chassis	Aluminum	17.00			
HDPE		65.00				
	Subtotal	82.00				
Donated	1/8"x12"x12" Aluminum Plate	20.00				
	DC Tools Motors	15.00				
	Machining Costs	350.00				
	Subtotal	385.00				
Miscellaneous	12"x12"x2" UHMW Block	102.00				
	SS fasteners/parts for tools	120.00				
	3D-Printed Connectors	50.00				
	AUX Connectors (male and female)	50.00				
	Epoxy	25.00				
	Laptop	551.98				
	Shirts	455.00				
	Subtotal	1,353.98				
Travel	Flight to Houston, TX	5,144.00				
	Shuttle to/from airport	323.00				
	Shipping ROV	150.00				
	Hotel	2,400.00				
	Subtotal	8,017.00				
	Total	12,938.12				
	Total (USD)	9,962.35				