

Titan Robotics
Corner Brook Regional High

Technical Documentation

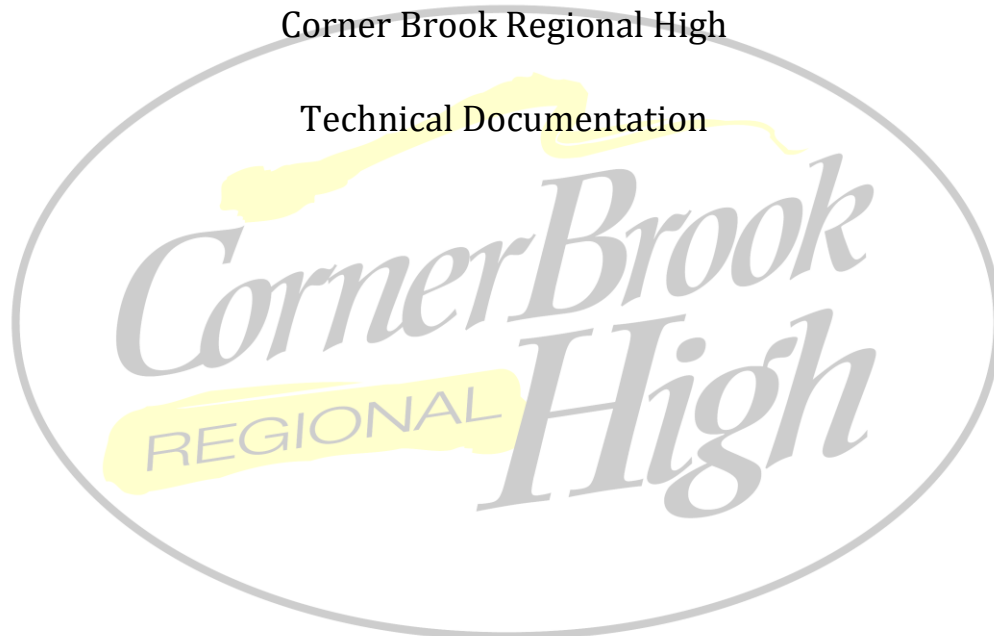

Victoria Byrne, *Team Captain*

Jared Hann, *Chief Executive Officer, Co-Pilot*

Evan Wheeler, *Chief Operations Officer, Pilot*

Jackson Rigler, *Software Developer, Arduino Specialist*

Marcus Bryne, *Chief Financial Officer*

Kyle Walsh, *Software Developer, Phidgets Specialist*

Taylor Bennett, *Systems Designer*

William Kean, *Scientific Research Specialist*

Grant Penney, *Fabrication Specialist*

Ben Jacobsen, *Electrical Specialist*

Thibault Chanus, *Public Relations*

Table of Contents

Section 1 – Abstract	Page 4
Section 2 – Company Overview	Page 4
Section 3 – Logistics	Page 5
3.1 – Project Management	Page 5
3.2 – Scheduling	Page 5
3.3 – Financing	Page 5
3.3.1 – Preliminary Budget	Page 5
3.3.2 – Project Costs	Page 6
3.3.3 – Financial Challenge	Page 6
Section 4 – Safety Practices	Page 7
4.1 – Operational Safety Practices	Page 7
4.2 – Vehicle Safety	Page 7
Section 5 – Design Rationale and Vehicle Systems	Page 8
5.1 – Design Philosophy	Page 8
5.2 – Major Constraints	Page 8
5.3 – Chassis	Page 8
5.4 – Stability	Page 9
5.5 – Propulsion	Page 9
5.6 – Display.....	Page 10
5.6.1 – Cameras.....	Page 10
5.6.2 – Video.....	Page 11
5.7 – Electronics Enclosure.....	Page 11
5.8 – Electronics.....	Page 12
5.9 – Tether.....	Page 12
5.10 – Topside Controls.....	Page 12
5.11 – Software.....	Page 13
5.12 – Payloads.....	Page 13

Section 6 – Lessons Learned	Page 15
6.1 – Interpersonal Skills Gained	Page 15
6.2 – Technical Skills Acquired	Page 15
6.3 – System Testing and Troubleshooting	Page 16
6.4 – Technical Challenge – Creating a Claw	Page 16
6.5 – Future Improvements	Page 17
6.6 – Reflections	Page 17
Section 7 – Acknowledgements	Page 19
Section 8 – Sources	Page 19
Appendix A: Operational Safety Checklist	Page 20
Appendix B: Fair Market Value	Page 21
Appendix C: System Integration Diagram	Page 22
Appendix D: Software Flow Diagrams	Page 23
Appendix E: Extra Photographs	Page 24

Section 1 – Abstract

The Titan Robotics team was formed in 2009 and operates out of Corner Brook Regional High School. This year's team consisted of 10 students, two team mentors, and our Team Captain and teacher sponsor, Ms. Victoria Byrne. The tasks designed by MATE this year for the Ranger competition simulate real world applications, with tasks focused on Entertainment, Commerce, Health and Safety, and Waste Management. This year our submersible ROV, Cherry, was built specifically for these tasks. Our company has designed specialized tools to perform certain tasks using programs like Solidworks and Mastercam. Being able to develop specific tools will allow us to succeed in performing the given tasks successfully and efficiently. One of the tools our team designed was custom camera brackets that allowed us to get a perfect bird's eye view position for our camera which makes completing the tasks much easier and faster, for example the cargo container task needs precise positioning of a sensor to determine hazard levels.

Section 2 – Company Overview

Titan Robotics is a company formed by a group of high school students based out of Corner Brook Regional High, Corner Brook, Newfoundland and Labrador, Canada. We specialize in developing reliable and efficient products for use in challenging marine environments. The Company prides itself on being at the leading edge of Remotely Operated Vehicle (ROV) technology and community leaders in safety and education. Titan Robotics has been a competitor in the Marine Advanced Technology Education (MATE) ROV Competition for the past 9 years. Most recently at the 2017 regional competition hosted in the company's home province of Newfoundland & Labrador, Titan Robotics placed second in a field of 14 competitors. We designed the vehicle with minimized size and weight, and maximized versatility and speed.

Section 3 – Logistics

3.1 – Project Management

This year, due to our new members and experience from past years of testing, the management of the project was very smooth and orderly. From day one every group member was assigned to a designated task outlining their strengths. Another helpful assistance was that the core members of the team all knew each other beforehand, creating a comfortable working environment almost instantly. While most of the weekly workflow came and went smoothly, minor issues would include a lack of activities for some members to do. Most of our issues were easily solved with a little discussion and fundraising, we hosted bottle drives as well as door to door fundraising for our cause. Our positions were chosen from a spectrum of tasks completed per member and their respective specialties. A well thought-out plan and a focused team has satisfied our end goals and created a successful project.

3.2 – Scheduling

Oct	Nov	Dec	Jan	Feb	Mar	Apr	May	Jun
Discussing fundraising	Budgeting	Research	Ordering Parts	Advising	Poster Board Begins	Competition Preparation	Testing	Internationals Prep
Recruiting	Assigning Roles	Bonding	Begin ROV Work	Position Selection	Fundraisers	Finishing Touches	Regionals	Internationals

3.3 – Financing

3.3.1 – Preliminary Budget

Administration	\$67.47 CAD
Electrical & Software	\$15.00 CAD
Mechanical & Technical	\$50.00 CAD
Total	\$132.47 CAD

3.3.2 – Project Costs

Preliminaries	\$132.47 CAD
Auto Transport	\$214.65 CAD
Chaperone Meals	\$137.82 CAD
Hotel Rooms	\$1510.50 CAD
Total	\$1995.44 CAD

3.3.3 – Financial Challenge: Transport vs. Material Investments

Due to our lack of capital at the beginning of the year, we had tough decisions to make regarding budgeting our funding between travel to the regional competition and purchasing materials for the ROV. As seen in Section 3.3.2, travel expenses took a large majority of our funds, meaning we had to make economic decisions on what to purchase for the new design. Transporting a team, chaperones, and equipment across the island of Newfoundland is always a challenge, and always a costly venture for a team with no large corporate sponsors. Our solution was to source used parts from the Industrial Arts room for much of the build, buying locally for new materials such as marine grease or heat shrink, and using vehicles of team member parents to transport us and the ROV out to the regional competition in St. John's, Newfoundland and Labrador.

Section 4 – Safety Practices

4.1 – Operational Safety Practices

For us, safety is the number one priority. We want to insure that no company member is injured in the construction or operation of the ROV. Before any operations begin, we first consult the Operational Safety Checklist (Appendix A) and Job Safety Analysis (JSA). By doing this we can be well organized and safe during setup, operation, and teardown of the ROV. The company has a common practice to pair up senior employees with inexperienced employees to run through hazards and safe practices associated with all job tasks. Titan Robotics' on-board system allows employees to discuss safety concerns in a comfortable one-on-one setting, fostering open communication and effective learning. If any unexpected safety issues occur, we stay calm, consult the JSA, and record the issue so future teams will be aware of the possible problems and how to solve them.

4.2 – Vehicle Safety

Cherry has been designed and manufactured with safety at the forefront and adheres to all specifications outlined in the 2017 contract's call for bids. Some of the key safety features include a 25A main fuse, hardware and software kill switches, thruster guards, and warning labels on power connections and moving parts.

Section 5 – Design Rationale and Vehicle Systems

5.1 – Design Philosophy

Our goal at Titan Robotics is to create the best user experience possible for the client, as well as being an inexpensive solution to completing underwater tasks. To successfully achieve this, the vehicle must be stable, move naturally when submersed, and have intuitive, logical controls for the pilot. By keeping the user-centered design philosophy in mind, Titan Robotics has developed a product which is not only capable of completing the 2017 contract, but is a pleasure to operate.

5.2 – Major Constraints

Operating on a small budget 700km away from our regional competition makes finance a fairly problematic issue. With limited funds we are forced to reuse outdated equipment, as well as having little funding for research and development. With only having a 48cm diameter frame, it limits the available space for thrusters and payloads. Working within these constraints requires creativity and innovation from the whole team.

5.3 – Chassis

The chassis of our ROV is designed as a cube in order to give us both stability and to have the best size to volume ratio possible with the restrictions given. The cubic structure is small and compact and gives us the ability to attach all of our needed payloads and other devices on the ROV with ease and simple procedures. The chassis is made out of PVC plastic, making it relatively light, resistant to cracks and breaks, and simple to construct and remodel. 13 PVC tubes are connected together to create the primary shape, all of which have custom-drilled holes to allow water to flow through the chassis to make it more hydrodynamic. The corners are connected by PVC elbow joints. These are three pronged connector pieces allowing us to join the main tubing together. A pipe intersects through the middle of the top on the ROV with a T-joint in its centre. This gives us a secure connection for the tether.

5.4 – Stability

Without an ROV that can stay neutrally buoyant and level in the water, the pilot's focus is taken off the tasks given and onto keeping the chassis from twisting and turning. This is why much of our design revolve around symmetry and neutral buoyancy. The design of our chassis, explained in detail in Section 5.3, is cubic, giving a perfect base to align all attachments with each other. The motors are placed on opposite sides of the top of the chassis, as well as either side. The tether attaches to the top-middle, and the buoyancy foam blocks are placed with precision to ensure that wherever the ROV is mid-flight it can maintain its position without the pilot having to think of it.

5.5 – Propulsion

Our company has decided to reuse our SeaBotix BTD 150 underwater DC motors. These motors weigh less than 1kg, giving them an effective weight to performance ratio. Each motor is capable of producing 19.4W of power and 2.75N of thrust. With the layout of our four motors, we are able to effectively move along the y-axis of the ROV, quickly move forward and back, as well as pitch left and right. Through our use of PWM motor controllers, we are able to adjust the velocity of the ROV. This, along with the stability of the robot (Section 5.4), allows for smooth flight of the ROV. This is extremely useful for completing complex missions off the port of Long Beach.

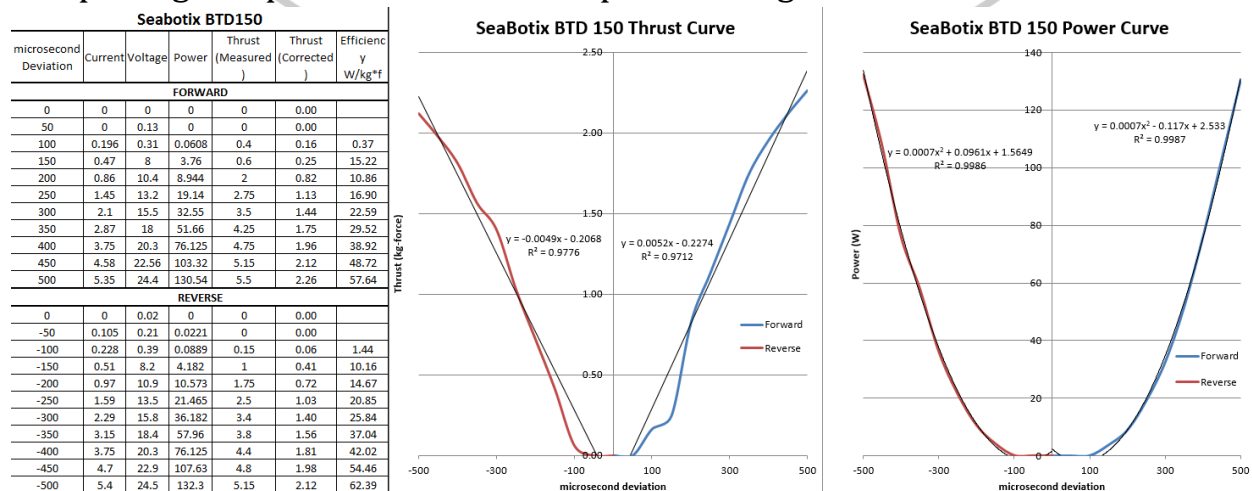

Displayed above are the technical graph (Left), Thrust Curve (Middle), and Power Curve (Right)

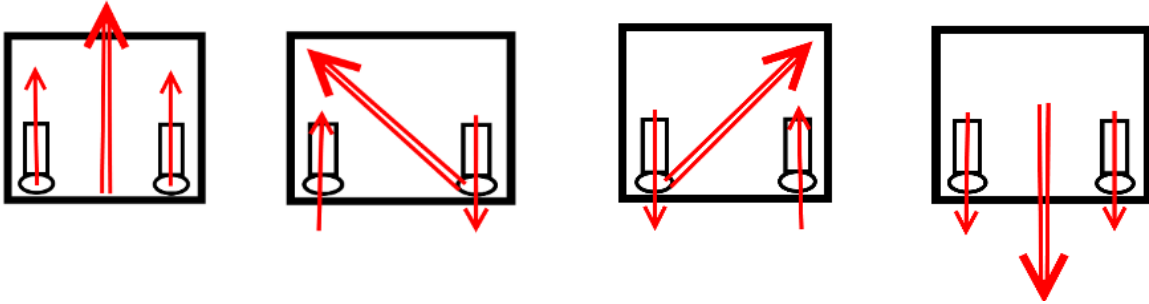

Here are the propulsion vector diagrams, depicting (from left to right) forward, left, right, and backward.

5.6 – Display

5.6.1 – Cameras

Cherry has two cameras, both of which have eight LEDs surrounding the camera to illuminate the pilot's field of vision. The main camera is used by the pilot to navigate the water, while our secondary camera is used to view the payloads, so that the driver can easily see their interactions with the props. The diameter of both our cameras is 8mm, and the length is 10mm.

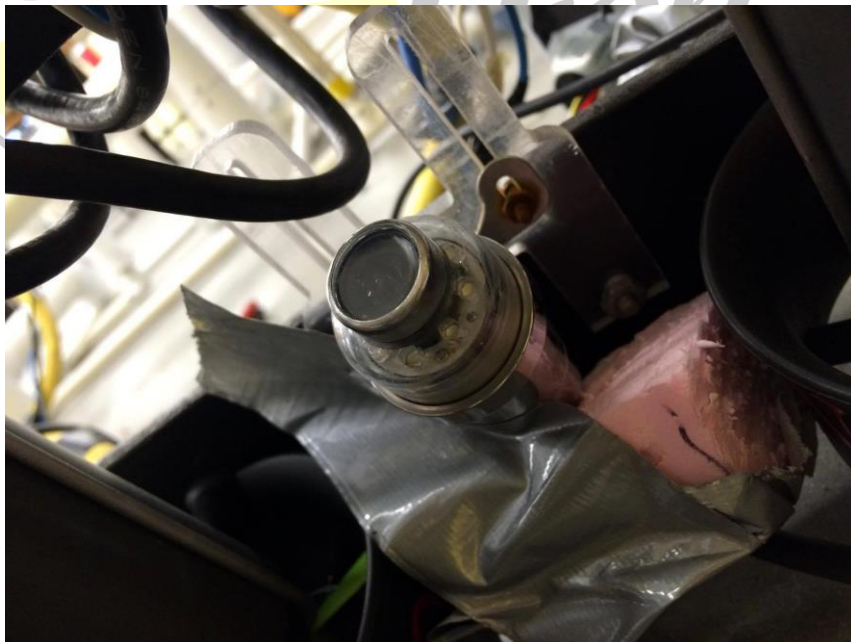

One of our cameras, custom mounted onto the back of the ROV.

5.6.2 – Video

Our video feed is an RCA input with a 720p from our primary and secondary cameras. The RCA cable is connected to our tether so it is secured and can safely provide video to the pilot. The video feed that the pilot sees from the cameras is run on a completely independent system from the ROV to provide the video so the pilot can complete the tasks. We chose to use the video system independent of the Phidgets and Arduino systems (Section 5.8) to keep the camera system simple and without unforeseen errors.

5.7 – Electronics Enclosure

The electronics enclosure for our ROV is a square reinforced plastic box. The design of the enclosure is not only robust and secure, but the plastic material also ensures that no electricity is being conducted to the exterior of the casing. The simple shape has allowed for an easy organization of the electronics on the inside. The Titan Robotics logo is clearly visible on the outside, giving the grey plastic a custom design.



This is our electronics enclosure with our logo over the top cover.

5.8 – Electronics

The electrical systems consist of both Phidgets and Arduino microcontroller systems. Phidgets are used for our 12V DC motors, and an Arduino Mega 2560 was used to control the claw. While the Phidgets boards are expensive and relatively large, the ease of use works very well when controlling the main motors using a 12V voltage. The Arduino system is excellent for interactions with the servo motors, and the open source model makes it easy for custom controllers, explained in Section 5.10. The options provided by using both Arduino and Phidgets gives us a wide range of options for software and custom innovations to aid the pilot and co-pilot, seen in Section 5.11. The main design flow of the electronics begins with the 12V power supply from the Anderson Powerpole connectors, which then gives power to the Arduino Mega 2560, the Phidgets 8/8/8 Board, the four Phidgets Motor Controllers, and the two cameras. Power is then supplied to the DC motors through the Motor Controllers, and to the two servo motors from the Arduino Mega 2560.

5.9 – Tether

Cherry is powered through an electrical tether, measuring 15 metres in length and 5.5cm in diameter. Due to our tether having its own floatation jacket that makes it neutrally buoyant, the tether has very low chances of getting caught up on the floor of the pool or tangled in certain props in the water. At the regional competition we had no issues with our tether, which was part of the reason for our success. It is a major asset for navigation in the pool when performing the given tasks.

5.10 – Topside Controls

To control the main motors that move the ROV, a Microsoft Xbox 360 controller is used. We have chosen this controller for the ease of use and customizability it offers. Our pilot, Evan Wheeler, worked with the Phidgets team to map the control scheme to his exact specifications. Being an avid video game player, piloting the ROV is just like playing a First-Person Shooter, meaning he is comfortable with the system and has become one of our best

assets for product demonstration. The Phidgets system also has PWM capabilities that are used in conjunction with the directional pad on the controller, allowing the pilot to adjust the speed. On the Arduino side, the innovative and experimental minds of Jackson Rigler and Ben Jacobsen have designed an ergonomic and fluent custom controller: iPeter™. iPeter™ is a wrist-mounted modular analog control system for the co-pilot to use to interact with our claw and laser. It consists of a joystick with two analog axis to turn the claw, as well as open and close the grips, and also features a digital switch to control our laser. iPeter™ connects to the main electrical systems in the electronics enclosure (Section 5.7) through the custom built PeterBolt™ cable.

5.11 – Software

We used Visual Basic 6.0 as our main program to control the motors and the movement of the ROV. The Arduino IDE was used to interface with the servo motors and iPeter™ (Section 5.10) through the Arduino Mega 2560. The considerate, critical thinkers in the Phidgets department designed a two-dimensional simulation of the ROV in real time while piloting to aid the pilot and co-pilot during missions. This replication also grants our team an additional advantage to test new functions without deploying the ROV into the water for fine adjustments in the control scheme. Values are displayed to the left of the screen if toggled to further discover any optimization issues, ensuring the smoothest experience when controlling.

5.12 – Payloads

Our primary tool that we use is our claw, operated by Jared Hann, the Co-Pilot. Having the co-pilot operate the claw allows the pilot to focus solely on ROV motion, so that fine adjustments can be made while the pilot focuses on keeping the ROV steady and in position. Another tool we use is a modular system for the sensor that interacts with the RFID interface provided by MATE in order to determine the contents of the cargo containers; part of the Safety and Risk Management tasks. We made the decision to implement a modular tool system this year to give our ROV versatility and vary our options for missions. All tool systems are displayed in front of our forward facing camera to give the pilot an optimized viewpoint of the various additions being used. We also have

a simulated Raman Laser that is attached to the inside of the ROV allowing us to position it over suspected contaminate and test it.



One of our modular attachments, used to interact with the RFID interfaces.

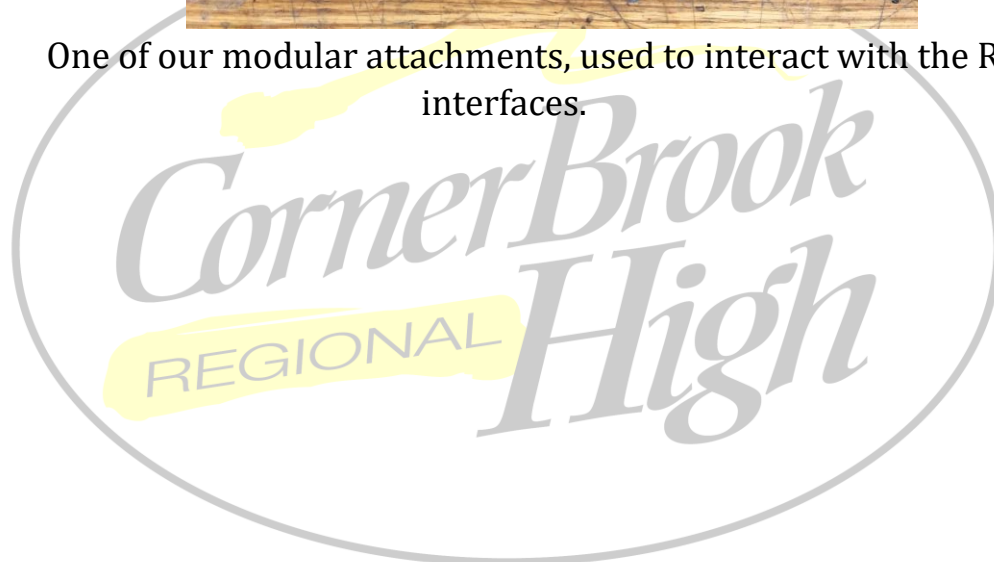

Section 6 – Lessons Learned

6.1 – Interpersonal Skills Gained

Working with a team takes coordination, dedication, and communication, and it takes practice to learn how to deal with varying personalities in a close working environment. But, when a team can cooperate with each other to accomplish goals together, the group becomes a single effective powerhouse that can exceed exponentially beyond what the individual members can do separately. This year our team met many challenges in working together. During the beginning of the year we had many member changes, and it took multiple months before we had a designated core team. After we found our 10 members, we learned how to work with one another, and generally had a pleasant time. Part of what we all enjoy about the experience of robotics is that everyone in the room is having fun. While we solder and wire we also talk and laugh; we always come in with high energy, ready to be productive. This light atmosphere also makes it easy to coordinate between different sections of the team. While we all have specialties and work on different areas of design and construction, we can still come together and plan with ease.

6.2 – Technical Skills Acquired

The integration of waterproofed servo motors and an Arduino system has expanded our knowledge on a variety of topics, allowing us to pursue more advanced methods of development. The use of Arduino was a challenge at first, as supplying a 12V voltage from a 5V microcontroller was not possible. We experimented with relay boards and motor shields, and learned much more about current and circuitry than we previously knew. The waterproofing process required varying methods to effectively stop leakage in the servo motors and wiring, and while it was a lengthy venture doing it this year, our techniques have greatly improved.

6.3 – System Testing and Troubleshooting

Testing consisted mainly of above water debugging. Once the chassis and control box configuration was finalized, experimentation began with Arduino and Phidget controllers. The process of optimizing software and controllers to our specific equipment took a few months, but the attention to detail and small adjustments before use in water paid off, as when we were ready to fly the ROV there were only minute errors to fix. Most of the troubleshooting occurred with implementing Arduino, a first for our team. Due to our limited funding we realized we could not use a full Arduino system and had to use Phidgets to control the main DC motors, but through the process we developed a method to use next year.

6.4 – Technical Challenge – Creating a Claw

Last year our design for the claw on our ROV was not very successful; our waterproof servos were only reliable up to a one metre depth. As soon as the ROV descended past that mark we lost function in the system. This year we started early with research and development on making sure the two servo motors we use to grab and turn would stay working through the missions. This turned out to be a larger challenge than we had hoped for. In the first few months we had varying failures with different materials such as liquid electrical tape – which we later learned would not work in chlorinated waters. But we persevered and continued testing. When it came time to perform at regionals the design was not completely finished, leaving us to create some last minute innovations on a static arm. These worked out fairly well as we could compete and even outperform against other teams with full functionality in their claw systems. In the end we discovered that smaller servos and food grade mineral oil could both be used to create less of a chance of leaks and create a neutral pressure on the inside of the servo against the outside in water.

6.5 – Future Improvements

Next year we plan to do three things: use Arduino motor controllers for our 12V DC motors, design a more compact and better managed control box, and create an improved claw system. This year we implemented an Arduino system for the claw, using a wrist-mounted controller called iPeter for the co-pilot to accurately move the device. However, we still continue to use Phidgets for the motor controls, and while the older microcontrollers have their advantages, and the Phidgets team made some exceptional code for the main controls, the Phidget boards are old, large, and expensive. Using Arduino is not only a cheaper option than Phidgets for replacements and system changes, it also allows us to downsize the size of the internal system and give us more options for control software and aiding the pilot by using specific and low cost sensors to determine object location, depth, and so on. By downsizing the size of the internal systems we have more options for a compact control box and a cleaner, streamlined topside electrical environment. Replacing our large plastic box with a modified mini ITX computer case would give us many more attachment options and cooling options if we decide to use any high current small electrical components. Parts would be easily detachable and could be easily changed at any time. As discussed in Section 6.4, the claw was a challenge this year that we learned much from, but was a liability in our ROV's functionality. Using the methods we discovered at the end of the year that were previously discussed will aid us greatly in improving our system with new innovations.

6.6 – Reflections

It was a hectic year at CBRH Robotics, and one that involved hard work and new innovations. We began without a core team and quickly lagged behind in our workflow, but soon recovered when our dedicated team members pulled everything together through teamwork and commitment. With a team assembled and tasks assigned, we quickly designed a small, robust, and powerful ROV that completed the missions given with relative ease. Our modular, strong design scheme meant that no matter what went wrong there was a solution. If we had a chance to do the year again, efficient workflow would be a priority, as at points there was confusion on our direction as a team

and what we were focusing on. This caused a lack of productivity, and the absence of that would give us a huge boost on the possibilities for what we could improve on. Our in-water testing was lacking this year as well, with our tight schedule it was difficult to plan testing and find venues to do so. However, overall we came out of the year with a successful design for our ROV and most importantly, a dedicated team, prepared for anything to go wrong with solutions to fix any problem we encounter.



Section 7 – Acknowledgements and Sources

Titan Robotics would like to thank the following organizations and individuals for their support in the development of cherry, our travel to Long Beach, and of the MATE ROV Competition both regionally in Newfoundland & Labrador and internationally.

- Kristian Wheeler and Liam O’Neil – Team mentors
- Paul Brett, Anthony Randell, Whymarrh Whitby, and Michaela Barnes – Logistical Support
- Victoria Byrne, Team Captain – Countless hours of time and support
- John Dennison, Rick Wheeler, Bruce Bryne - Time and support
- Eastern Edge Robotics
- Atlantic Canada Opportunities Agency
- Crosbie Group Limited
- Government of Newfoundland and Labrador
- CyrstalCa Imaging Inc
- Furgo
- Hibernia
- Husky Energy
- Marine Institute
- Memorial University of Newfoundland and Labrador
- Statoil
- Subsea 7
- sfGIF
- Corner Brook Regional High
- Greenwood Inn & Suites
- MATE Centre

Section 8 – Sources

marinetech.org

phidgets.com

amazon.ca

bluerobotics.com

Appendix A: Operational Safety Checklist

This is our setup and safety assurance guide, designed specifically for our needs to ensure all systems are functional and all procedures are completed without error.

Step 1: Check Clothing/Personal Equipment

- Check if all shoes are tied (must be closed-toed)
- Ensure none of the deck crew are wearing loose-fit clothing
- All members of deck crew are wearing PFDs

Step 2: Ensure ROV and Topside Systems are Prepared

- Ensure tether is properly coiled
- Check all wired connections on the ROV system
- Check PVC joint connections

Step 3: Prepare ROV for Deployment

- Ensure electronics enclosure is secure on table
- Position ROV near water
- Ensure all deck crew are in designated positions

Step 4: Timed Setup

- Insert Anderson Powerpole connectors to power supply
- Attach RCA camera connectors to monitors
- Turn on monitors
- Ready ROV for deployment

Step 5: Deployment

- Pilot and Co-Pilot confirm both are ready for deployment
- ROV Retriever ensures they have secure footing on deck
- ROV Retriever deploys the ROV

Step 6: Teardown

- Ensure ROV is secure on deck
- Properly wrap tether
- Detach RCA and Anderson Powerpole connections
- Deck crew carries all systems off deck

Appendix B: Fair Market Value

Item	Amount of Item	Price of One (CAD)	Price of All (CAD)	New/Reused
SeaBotix BTD 15	4	\$599.99	\$2,399.96	Reused
Underwater Cameras	2	\$99.99	\$199.98	Reused
Phidgets 8/8/8 Interface Board	1	\$108.10	\$108.10	Reused
Phidgets Motor Controller	2	\$162.21	\$324.42	Reused
Arduino Mega 2560 (Sainsmart)	1	\$23.99	\$23.99	Reused
Waterproofed Servo Motor	2	\$29.99	\$59.98	New
Joystick	1	\$2.99	\$2.99	New
Xbox 360 Controller	1	\$44.99	\$44.99	Reused
Control Box	1	\$32.10	\$32.10	Reused
15m Tether	1	\$320.00	\$320.00	Reused
Claw Casing	1	\$10.00	\$10.00	Reused
PVC	12 feet	\$6.00	\$6.00	Reused
Marine Grease	1	\$17.23	\$17.23	New
Marine Epoxy	1	\$25.29	\$25.29	New
Plasti-Dip	2	\$24.99	\$49.98	New
Total	-	-	\$3625.01	-

Appendix C: System Integration Diagram

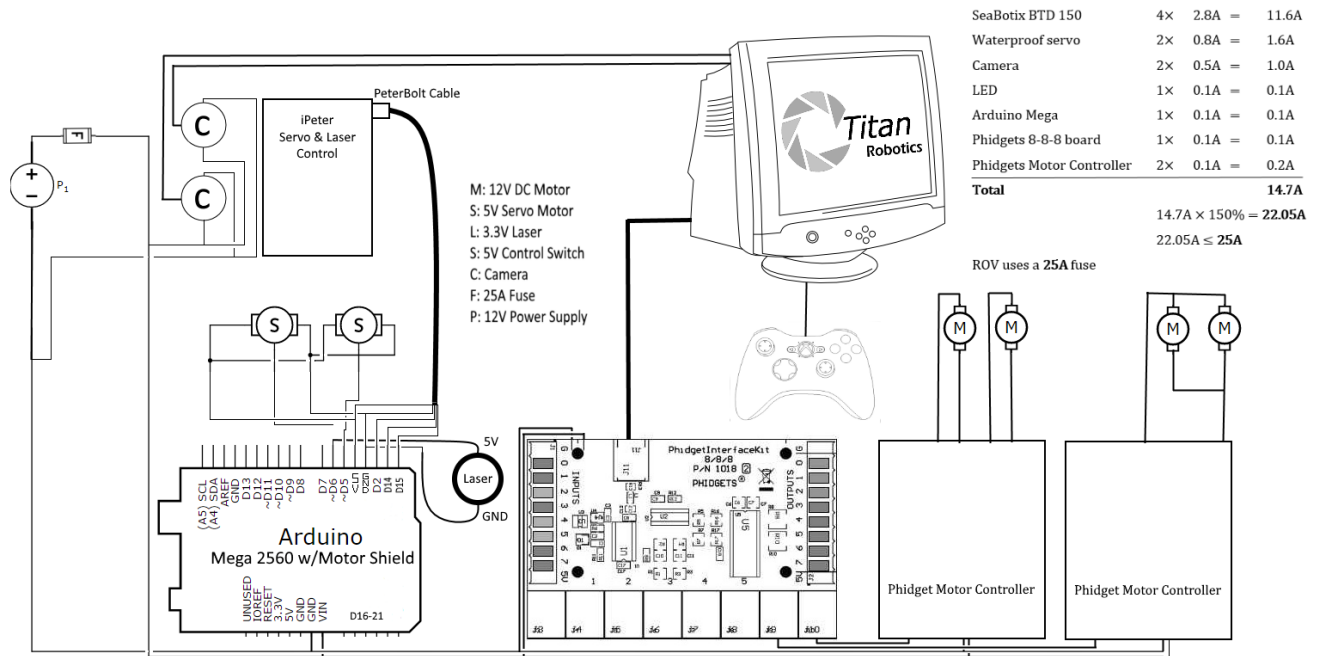

This is our System Information Diagram, displaying the electrical control flow, all inputs and outputs, and our amperage calculations.



Appendix D: Software Flow Diagrams

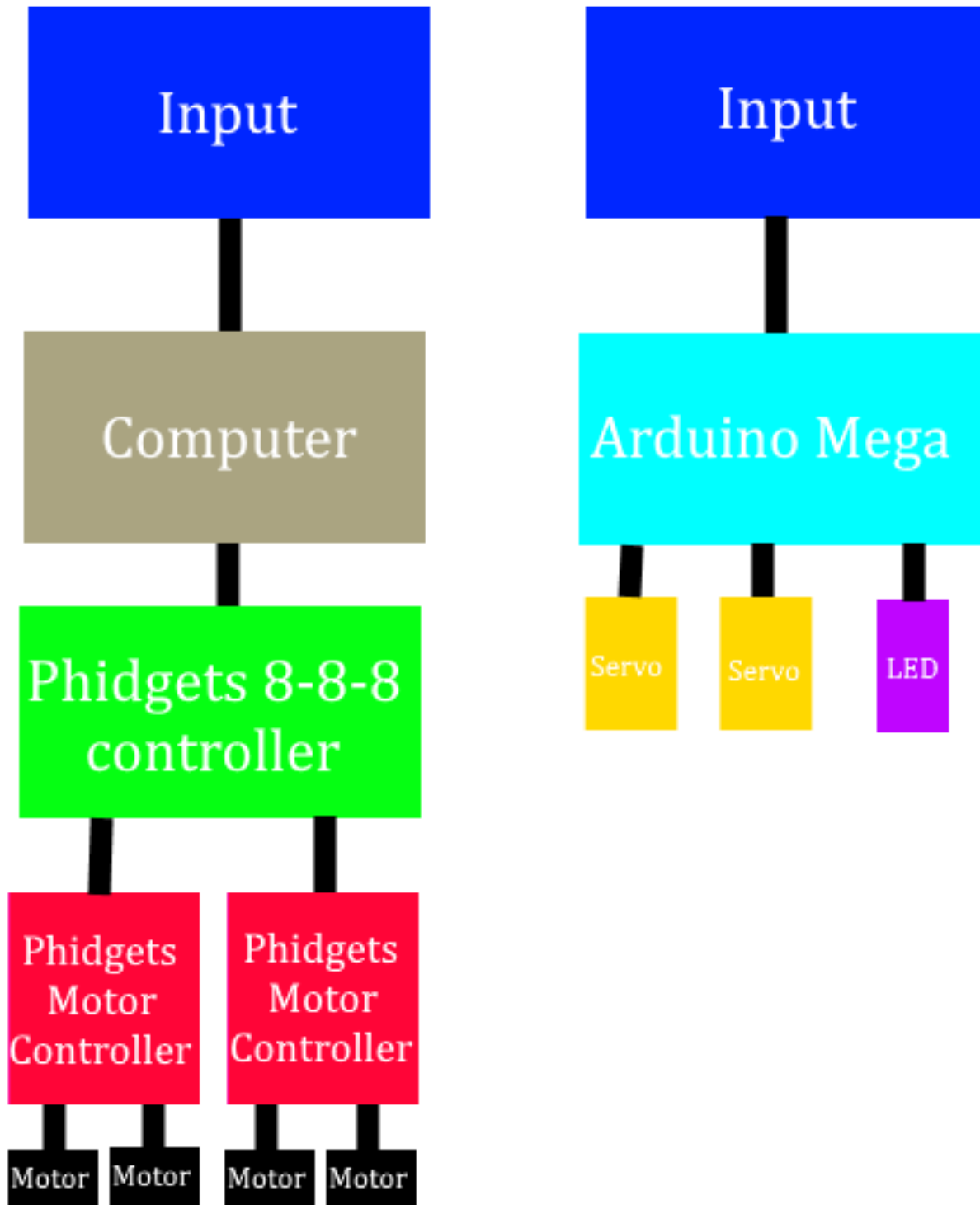

Appendix E: Extra Photographs

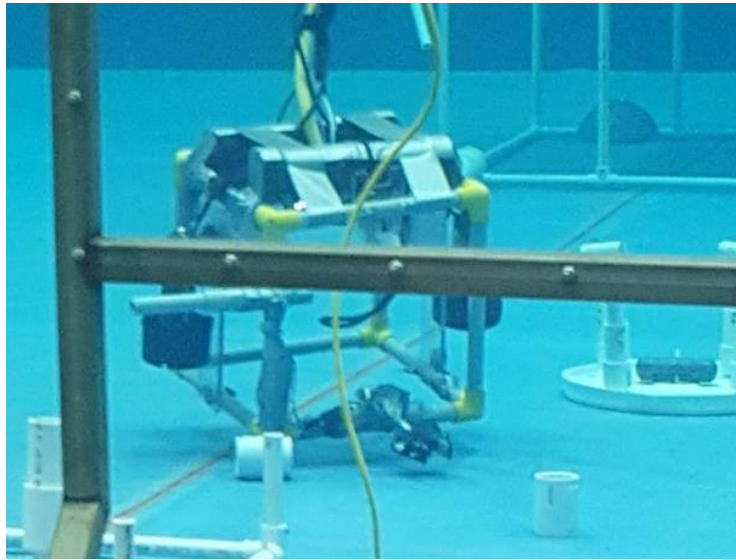

Our ROV in action at the Marine Institute in St. John's, NL

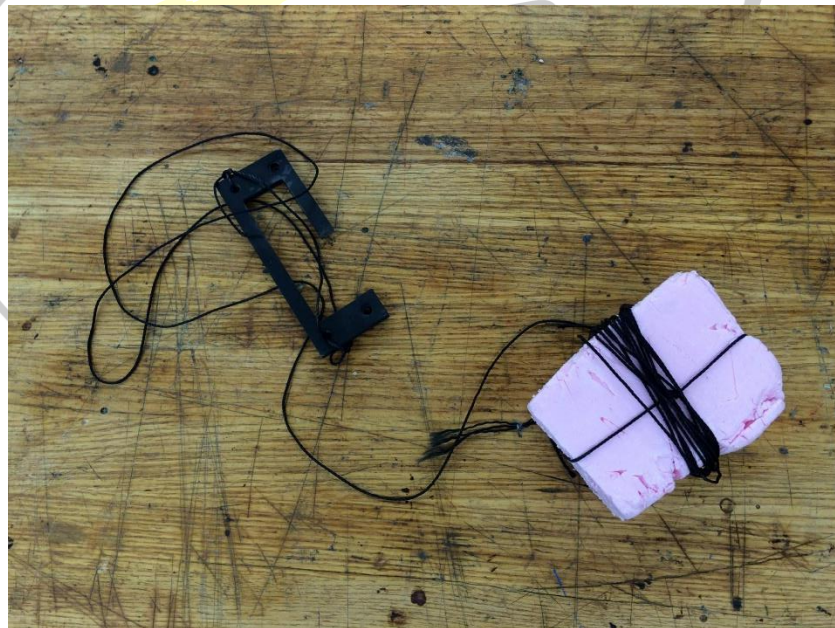

Our deployable buoy



Team photo, from left to right

Row 1 [Victoria Byrne, Taylor Bennett, Will Kean, Marcus Bryne, Kyle Walsh, Ben Jacobsen]

Row 2 [Evan Wheeler, Jared Hann, Grant Penney, Jackson Rigler]

Row 3 [Thibault Chanus]