

Mate ROV International competition 2017

Eureka C- Shark

Eureka Tech Academy, Amman, Jordan



MATE
MARINE
ADVANCED
TECHNOLOGY
EDUCATION
CENTER

Eureka
Technical Report

يوریکا

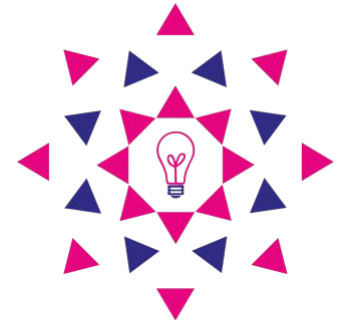

Eureka
يوریکا

Bader Ali Quadorah (10th Grade): Chief Executive Officer; Mechanical Support

Raad Amer Kloob (9th Grade): Chief Marketing officer

Omar AL-Omari (9th Grade): Chief Operational Officer; Editor

Khaled Al-saidi (9th Grade): Mechatronics Engineer

Hamzeh Jamal Shaddad (8th Grade): Mechanical Engineer

Mahmoud Omar Hasan (Engineering Student): Supervisor |Mentor; Technical Support

Emad Belal AlOmari (Engineer): Supervisor | Mentor; Technical Support

Table of Contents

I. Introduction.....	3
Abstract	3
Team Profile	4
II. Hardware selection	6
III. Design Concept	12
Frame	12
Dry Housing.....	13
Tether	13
Software and control system.....	14
Propulsion	15
IV. Safety	17
V. Challenges and added experience	19
VI. Future work.....	20
VII. Budget.....	22
VIII. Appendices.....	24
System Interconnection Design -SID-:.....	24
Flowchart.....	25
Acknowledgments.....	26

I. Introduction

Abstract

Eureka tech academy started in 2014, an academy first of its kind in Jordan to teach kids about electronics, robotics and other engineering subjects making some innovative future engineers, we've participated in many regional and international competitions, but never in the underwater robotics field! MATE has given us this opportunity in which we will be the first Jordanian team to be a part of ROV competition, also first Jordanian team become knowledgeable about underwater technology.

Our antique ROV; C-Shark, which we started by a sketch on small piece of paper 6 weeks before the competition, aiming to win in our first Jordanian ROV competition for the first time, so we have started designing, developing and hacking every possible single available instruction that can help achieving our target, our first task was to structure our design, furthermore we added the thrusters, then began Testing it in the water until we accomplished the upgrade, so our C-Shark with an copier to see, arm to grab equipment, actuators to shift around to detect the sea's and help humanity.

By taking the advantage of a team that consolidates the knowledge of mechanical building, electrical and electronic understanding and computer geeky types of people, C-Shark is alive.

Our new ROV feature is fully designed by computer using SolidWorks and build with high quality to achieve the tasks of the long beach problems.



Figure 2 Our first ROV design to participate the Arab ROV competition

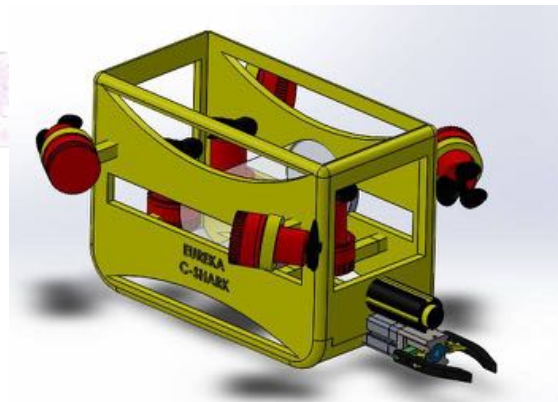
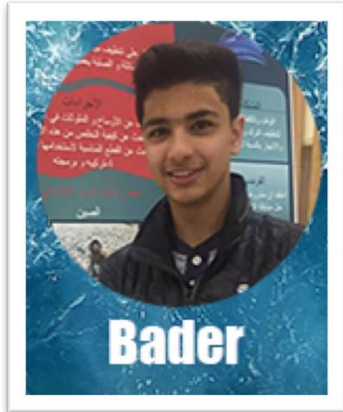

Figure 1 Our new design, with a pre-simulation

Team Profile

Our team is made up by 5 Members in ages between 14-15 years old and 2 supervisors, starting professionally, we aimed to put tasks to each member fitting their interests to make the process much more organized.



Bader Quadorah: CEO

15 YEARS OLD HE LOVES ROBOTICS AND PROGRAMMING SO MUCH, HE HAS THE LEADER SPIRIT TO PRODUCE MORE LEADERS AND A QUOTE HE FOLLOW: "A LEADER IS ONE WHO KNOWS THE WAY, GOES THE WAY, AND SHOWS THE WAY. "

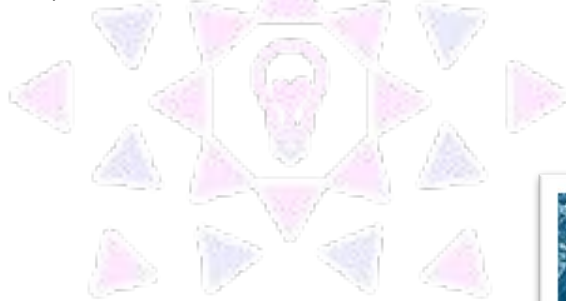

Raad Kloob: CMO

THE ONE WHO USES THE DRILL MORE THAN HIS SMARTPHONE ... THE TECHNICIAN Raad kloob IS 15 YEARS OLD WHEN HE WAS YOUNG I HEARD THAT HE HAD BROKE EVERY TOY AND REMOTE IN HIS HOUSE SO HE CAN KNOW WHAT IS INSIDE IT BUT HE NEVER DID KNOW UNITL NOW, HE IS A MECHANICAL AND AN ELECTRICIAN SPECIALIST.



Hamzeh Shaddad: The Mechanical Engineer

A MAN WHO ALWAYS SLEEPS WITH WIRES AND RESISTORS, THE ELECTRICIAN HAMZEH SHADDAD IS 14 YEARS OLD HE WORKS WITH EMBEDDED SYSTEMS AND HE IS ALSO C-SHARK PHOTOGRAPHER HAMZEH IS ALWAYS READY FOR FIGHTS HE HAS HIS SILICON GUN AND THE SOLDER



Omar Al-Omari: COO

The big mind who is always 5 steps ahead, working on making the ROV building easier and provide the supplements when needed.

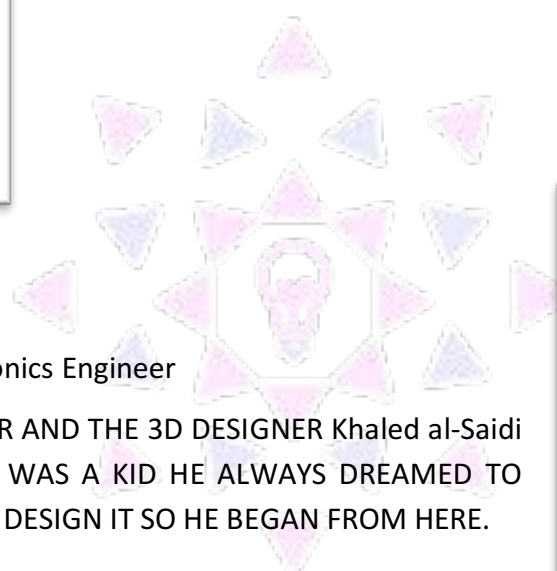

Khaled Al-saidi: The Mechatronics Engineer

THE MAIN GRAPHIC DESIGNER AND THE 3D DESIGNER Khaled al-Saidi IS 14 YEARS OLD, WHEN HE WAS A KID HE ALWAYS DREAMED TO BUILD A SUBMARINE AND TO DESIGN IT SO HE BEGAN FROM HERE.

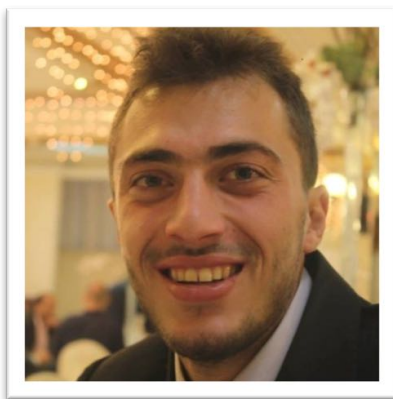

Emad Al-Omar & Mahmoud Hasan
Mentors Of the team

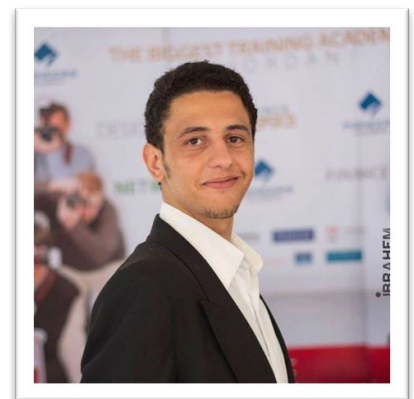

II. Hardware selection

The controller (remote)

We've been searching for the best way to control our ROV, so we couldn't find better than an original PS2 controller, for us it was the best way to control our ROV, we used Arduino-micro controller to program it, we connected the controller circuit to the Arduino and started programming it right away, we programmed it to go in all directions smoothly using 7 motors, so for us it's like playing a game!

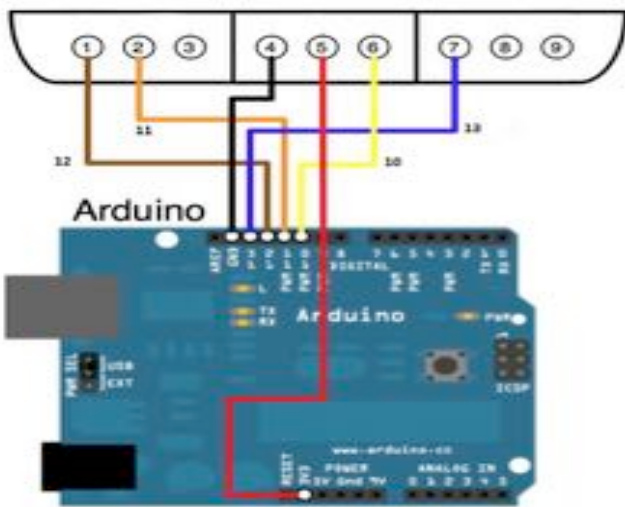

Figure 4



Figure 3

Arduino MEGA:

Because we are using PlayStation Joystick with Arduino, we used `<PS2X_lib.h>` Arduino library to let us control Arduino through the joystick.

The seven pumps are connected to the Arduino board through drive circuit using relays to switch.



Figure 5

Bilge pump:

Bilge pumps is the best choice for our ROV. One of our challenges is the lack of available underwater technology products.

We ordered many different of motors but it stuck in the customs, we had to order bilge pumps from USA and ask one of our partners to bring it to the team.

The easy way to control the pump and low cost let the team to think about using bilge pump instead of other motors.

We used 5 pumps with 1100gph and 2 pumps with 600gph, four pumps with 1100gph to let the ROV move forward and backward, three motors (one 1100gph and two 600gph) to make the ROV goes ups and downs.

To use bilge pumps with the best performance, we had to hack it and change the blades of the pump motor.



Figure 6



Figure 7

Key features:

- Easy clean snap lock strainer
- Silent operation
- Compact, efficient long life motor
- Rust and Corrosion protection
- Anti-Airlock protection
- Exclusive moisture tight seals
- Marine grade blocked wiring

Relay module:

To control the direction of ROV we should control the direction of ROV pumps direction, because we are using permanent magnet DC motor we built 7 H-bridge circuits with 14 relays (two modules, 8 relays in one module).

Controlling the relays on and off letting us to move the ROV forward and backward.

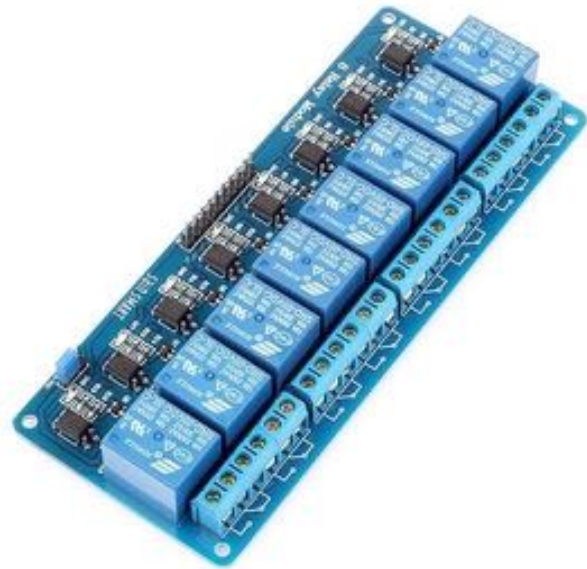

Figure 8

Features:

- Size: 13.5 x 5.3 x 1.7cm (LxWxH)
- Working voltage: 5V
- Channel: 8 channel
- This relay module is 5V active low.
- Relay output maximum contact is AC250V 10A and DC30V 10A.

Servo

This TowerPro 360 Degree Servo with 13kg/cm stall torque is a good choice for your RC airplanes, it is suitable for Eureka C Shark ROV to make a full rotation (360).

Specification:

- Brand: TowerPro.
- Model: MG995.
- Type: Metal 360 Degree Servo
- Dimension: 5.4 cm x 4.4 cm x 2.0 cm.
- Stall Torque (4.8V):13kg/cm
- Stall Torque(6.0V):15kg/cm
- Speed (4.8v):0.17sec/360degrees
- Speed (6V):0.13sec/360degrees
- Operating voltage: 4.2-6V.
- Temperature range: 055.
- Weight: 48g



Figure 9

Eureka
سوريكا

Camera:

Selecting the camera was a big challenge for the team, the team firstly used USB camera with USB extender, the team faced a problem with the USB webcam that the signal of the camera did not reach to the monitor, the problem has solved with using three USB repeaters to amplify the signal, the problem of using USB repeater with 30



Figure 10

meters is the lag of signal, the monitor was receiving the signal with lag.



① 720p HD video chat
For a true HD-quality experience.

② Widescreen
16:9 format offers cinematic video recording.

③ TrueColor technology
TrueColor technology automatically delivers bright and colorful video, in virtually all lighting conditions.¹

1 TrueColor technology supported on Windows 8, Windows 8.1 and Windows 10.

Dimensions
Length: 4.3" / 109mm
Width: 1.75" / 44.5mm

Certified for Skype
Do more together in HD, with Skype certified HD LifeCams from Microsoft.

Noise reducing microphone
Crystal-clear audio and built-in omnidirectional microphone with acoustic noise cancellation.

Universal attachment base
Works on your desktop, laptop, or notebook.

Figure 11

After many attempts to solve the problem we used another type of camera that can transfer the signal within 30 meters without lag.

The team used this camera for the ROV because its features:

1. Ideal for monitoring aquaculture
2. Underwater exploration
3. Ocean/ice/lake fishing
4. Underwater salvage
5. Contain 24 LED



HD 600 TV lines camera, provides super clear image. Figure 12

With 24pcs bright white LED light let you to see underwater clearly in both day and night.

Fish model design, waterproof and durable ABS camera housing, with two camera-balancing weights design.

Cold-resistant, waterproof and pull-resistant 5mm cable (20M / 30M optional).

Connect to most camcorders with standard A/V plugs, TVs, VCRs, portable monitors and LCD screens with AV input.

Specifications:	
Sensor	: 1/3" CCD SONY
Sensing area (mm)	: 4.9 * 3.7
Power supply	: DC 12V
Resolution	: 600 TVL
Camera light source	: 24pcs LED super bright white lamps
TV system	: PAL
Working temperature	: 20 ~ +75°C
Storage temperature	: 40 ~ +85°C
Lens angle	: 92°
Lens size(diameter)	: 35mm

Gripper:

After designing ROV gripper we used center lock motor cars as a solenoid to close the gripper and open it.

The solenoid is to convert the liner motion to rotational motion using gears.



Figure 14



Figure 13

III. Design Concept

Frame

This year the ROV's mission is to clean long beach bay and to find dangerous chemicals, so our design has been in restrictions so it could achieve the mission slightly and simply, but one of our problems in the regional competition was a weak and a heavy frame, For the international competition the team brainstormed to find a new material for the frame rather than the PVC pipes that could be more solid, lighter and more adjustable, so the team ended up with using acrylic plates and that was the best choice.

We used solid works to simulate and draw our new design and take it to the laser cutter to finalize the frame.

In the ROV structure, the center of gravity and the center of buoyancy were intended to happen in such a way that it became passively stable.

(x = 16, y = 25, z = 32.2)

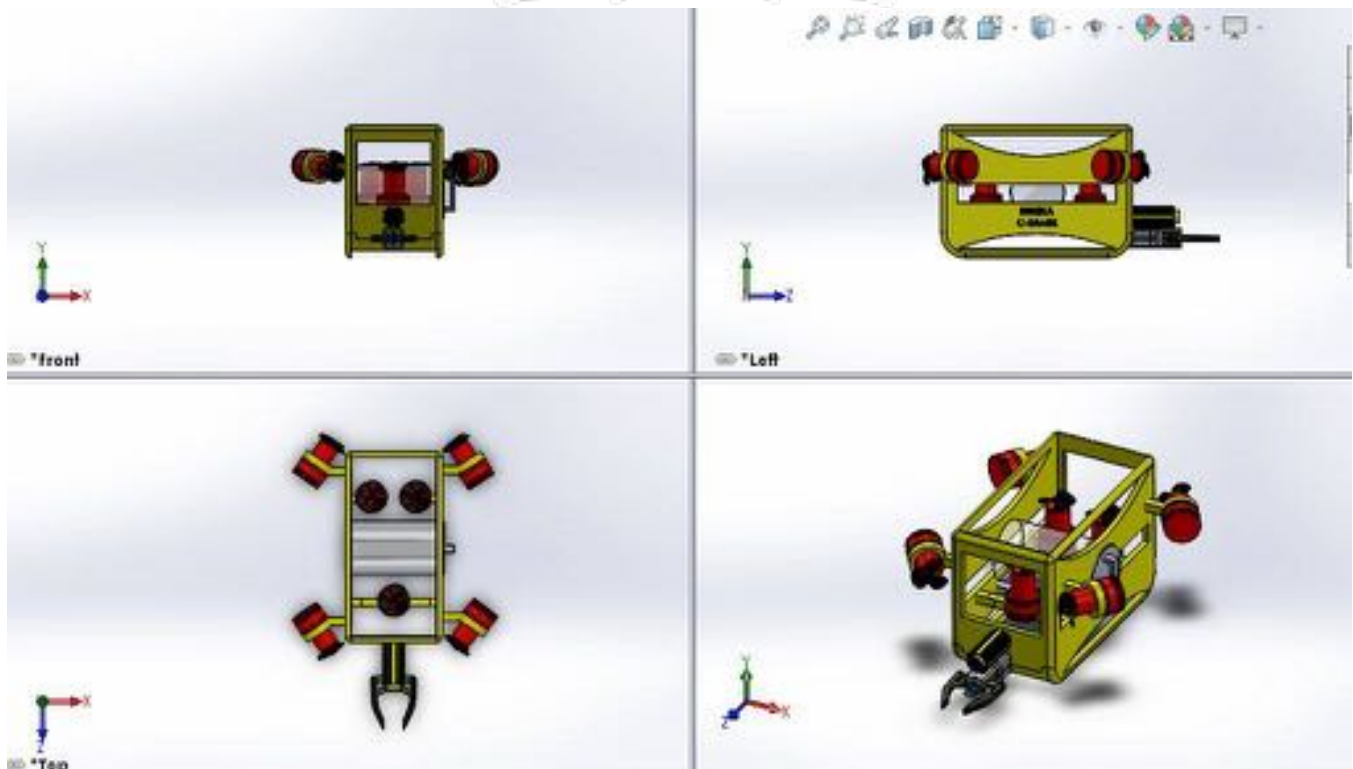

Figure 15

Dry Housing

We used a 3d printer for the motor housing so we can customize it and for connecting the housing with a modified RULE bilge pump for use with an underwater ROV, this mount will except a modified rule bilge pump motor for use with an underwater ROV. it will make mounting the thruster motor much easier than wire ties or hose clamps. The inside holes have been recessed. Pump mount can be mounted to the ROV frame vertically or horizontally. The mounting hardware is setup for M5 nuts and pan head bolts.

It was designed using Solid works and 3D printed to be used in the ROV.



Figure 16

Tether

For the power the team used 30 meter of 3mm cables, for signal the team used Ethernet cable.

Software and control system

We used Arduino board as a tool for our control system, the programming language was Arduino C.

Control permanent magnet DC motor require to control the voltage terminal by increasing and decreasing and changing the polarity. Because the voltage power supply at max is 12v we did not change the amount of input voltage.

The only way was to control the direction at maximum voltage (12v), to control the direction we built H-Bridge circuits with relays as switches to change the polarity.



Figure 17

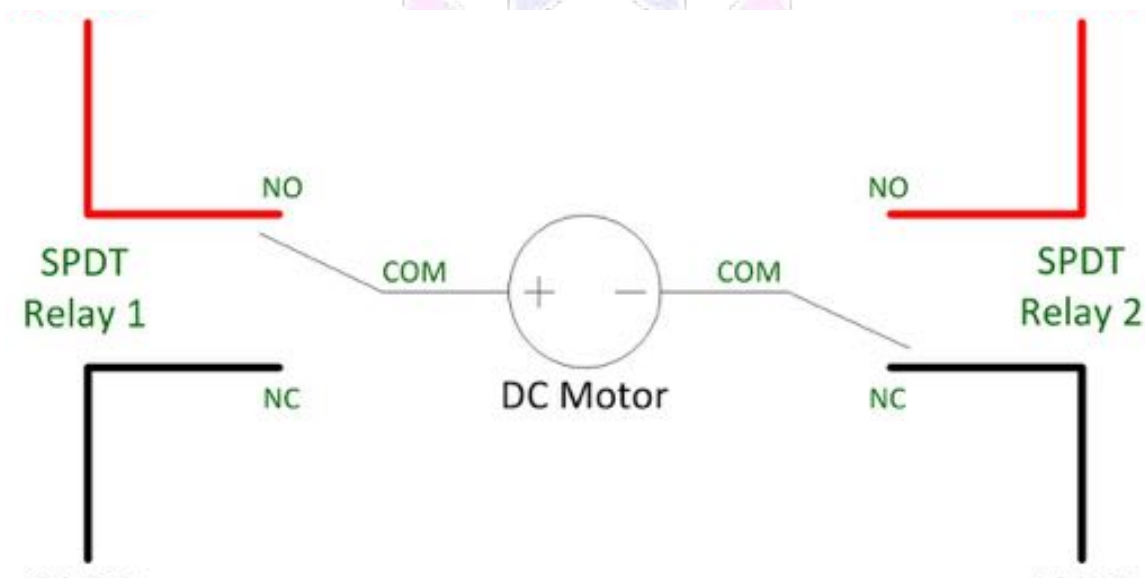

Figure 18

To control the Arduino board, we used Playstation 2 joystick with Arduino library, that make from the joystick a good remote control to control the ROV.

Propulsion

We have 4 motors to control the 2d movement of the ROV underwater, and 3 to control the up and down movement as in the following figure.

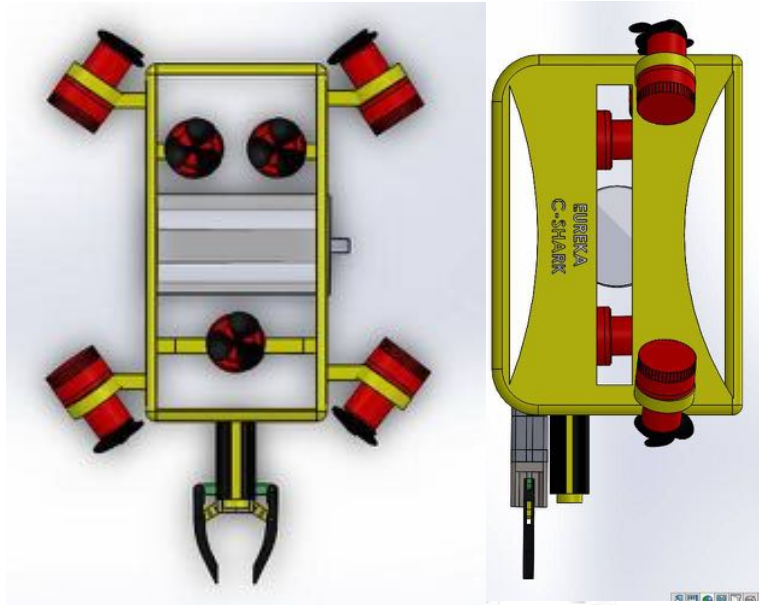

Figure 19

Eureka
یوریکا

So that the 2D movement will be as follows:

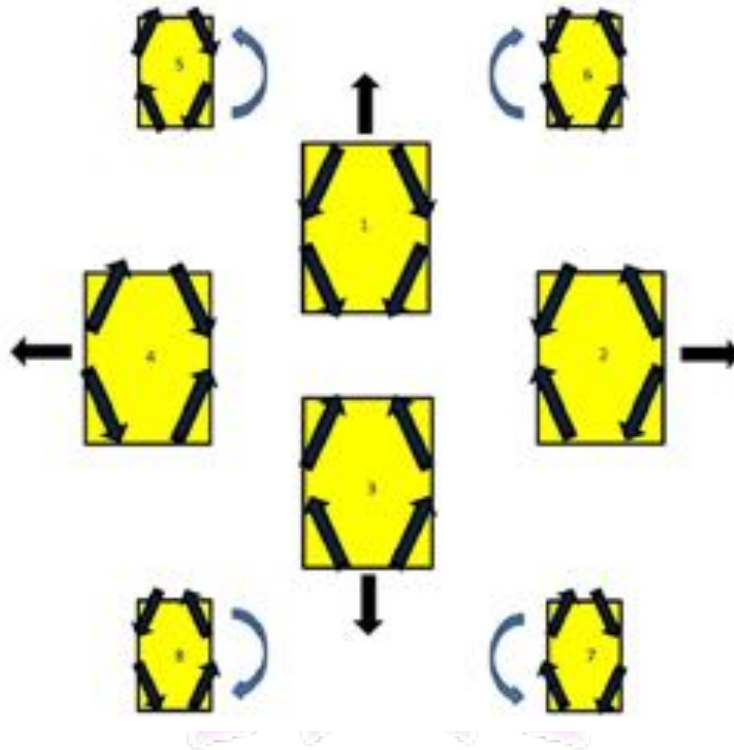
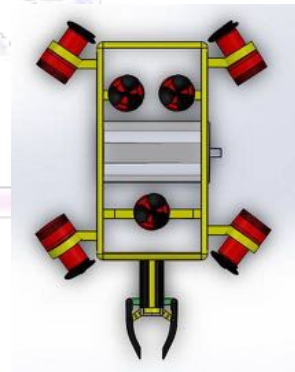

Figure 20

The Numbers from 1 to 8 specifies the following motion:

No.	Direction
1	Forward
2	Crab Right
3	Reverse
4	Crab left
5	Rotate/Turn Left-Forward
6	Rotate/Turn Right-Forward
7	Rotate/Turn Right-Backward
8	Rotate/Turn Left/Backward



The 3 up and down motors does keep the moment constant, the alone motor has 1100GPH and the couple have around 600 keeping the moment around the center stable.

IV. Safety

Once we started working on the ROV, safety rules for the team and for the ROV had been set:

- Tear resistant non-conductive gloves.
- Make sure all electric cables are covered and all endcaps are securely closed.
- Wear life jackets. Do not launch ROV alone.
- Make sure the Epsilon is placed on a dry location and hands are dry always.
- Verify power switches and circuit breaker on Tether Control Unit.
- Administrative Controls: Use proper disposal protocols when disposing of un-wanted chemicals.
- Ensure no obstacles near deployment. Only allow hands and arms in water. Must have good balance and secure footings.
- Ensure every member handling tools has been trained for its use.
- Ensure power tools are connected to grounded power supplies.
- Proper ventilation in designated work area (use Reduction of Harmful Substance) compliant lead solder, or lead-free solder.
- Use a cart to transport ROV.
- We made our ROV to be safe and from the things we made it that the work on it would be safe.
- Tear resistant non-conductive gloves.
- Make sure all electric cables are covered and all endcaps are securely closed.
- Wear life jackets. Do not launch ROV alone.
- Make sure the Epsilon is placed on a dry location and hands are dry at all times.
- Verify power switches and circuit breaker on Tether Control Unit.
- Administrative Controls: Use proper disposal protocols when disposing of un-wanted chemicals.
- Ensure no obstacles near deployment. Only allow hands and arms in water. Must have good balance and secure footings.
- Ensure every member handling tools has been trained for its use.
- Ensure power tools are connected to grounded power supplies.
- Proper ventilation in designated work area (use Reduction of Harmful Substance) compliant lead solder, or leadfree solder.
- File and mark sharp edges down with colored electrical tape.
- Personnel are to be in pairs. While one does the task the other supervises.
- Use safety glasses/goggles.
- Have a teammate or guardian supervise.
- After using device, disconnect and/or set power off.
- Lifting fragile objects with precaution.

- Make sure that the instrument has cooled down before putting it into storage.
- Keep all equipment in its place.
- Do not touch Control Box with wet hands.
- Follow all checklists, keep extension cord dry.
- Use fuse, diodes, comply with MATE regulations. No power supply in water.

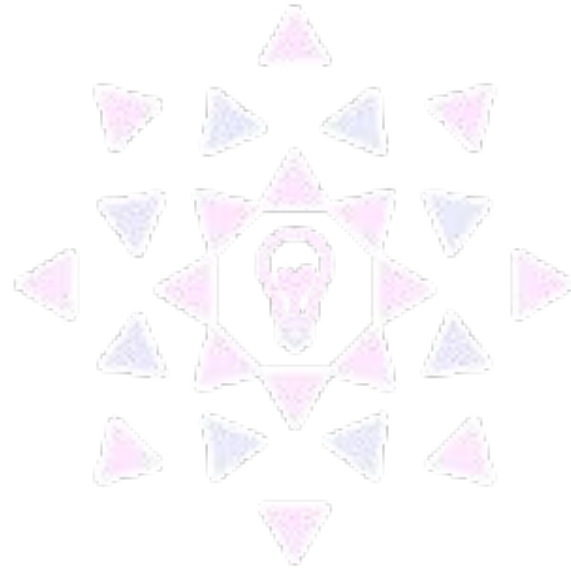

Eureka

یوریکا

V. Challenges and added experience

As the first team ever participating in the MATE ROV competition from Jordan; we learned the culture of underwater technologies and got involved in, we are now working on spreading it using all the possible ways due to the lack of underwater technologies awareness in the region.

As for the mechanical part, we've been through several difficulties, highlighted by the webcam, in Jordan there is no waterproofed webcams, so we had to make our own **Waterproof webcam "DIY"** with mechanical isolating such as locking the webcam in a glass bottle and with chemical materials to isolate it from the inside, adding the signal transfer problems as we had a weak signal when we first used a normal PC webcam with a USB extension; the solution was to add a USB repeater instead of a normal USB extension.

The buoyancy itself is another story, the simulation did not give the expected results thus we turned to trial and error based on the given data.

To summarize:

- This project has a huge effect for all team members, starting from technical skills to team management skills.
- the lack of many equipment in electronics and engineering market at Jordan and the rules of customs and traditions in Jordan forced us to work with many out of the box ideas, making the process very hard.
- in our last attempt, we could drive the ROV with imbalance, after many attempts of adding weights, empty tanks, foam material we could make a balanced ROV.

Eventually we managed to build our C-Shark that could do all the specific mission tasks which passed all the safety checks required.



Figure 21

VI. Future work

Eureka
یوریکا

Old ROV	new ROV
We used bilge pump	We will use brushless motor
We used one camera	We will use more than one camera
We used 3d plastic material for the motor housing	We will used aluminum material for the motor housing
We made the frame of the ROV by laser cutting (plastic parts)	We will aluminum for the frame of the ROV
The remote control is joystick of Playstation 2	We will use better joystick to control the ROV
We did not use pneumatic	We will use pneumatic

یوریکا

VII. Budget

Total

\$817.00

Item No.- Name	Cost	QTY
Item 1- Bilge Pump 600 GPH	\$90.00	3
Item 2- Bilge Pump 1100GPH	\$100.00	4
Item 3- Arduino uno	\$10.00	1
Item 4- Waterproof Camera	\$60.00	1
Item 5- Cable 20 Meters	\$80.00	1
Item 6- ROV Remote Controller	\$15.00	1
Item 7- Gripper	\$10.00	1
Item 8- Servo Motor	\$40.00	2
Item 9- ROV Anthropomorphic	\$170.00	1
Item 10- Relays	\$42.00	14
Item 11- Power Supply	\$40.00	1
Item 12- Camera DVR	\$55.00	1
Item 14- DVR LCD	\$50.00	1
Item 15- Heat Shrink 2Meters	\$2.00	1
Item 16- Fuse 30A	\$3.00	1
Item 17- Fuse 5A	\$7.00	7

Item 18- Laser	\$15.00	1
Item 19- Magnet	\$8.00	1
Item 20- Flashlights	\$20.00	1

Travelling and Accommodation:

Flight tickets: 11,000 USD

Accommodation: 4300 USD

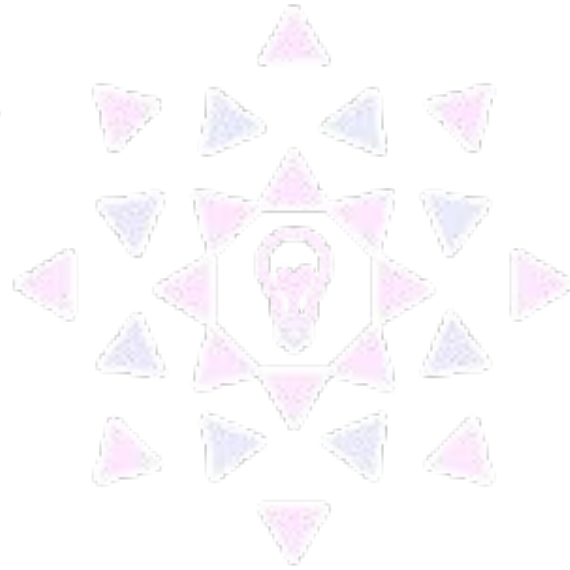

Eureka

یوریکا

VIII. Appendices

System Interconnection Design -SID-

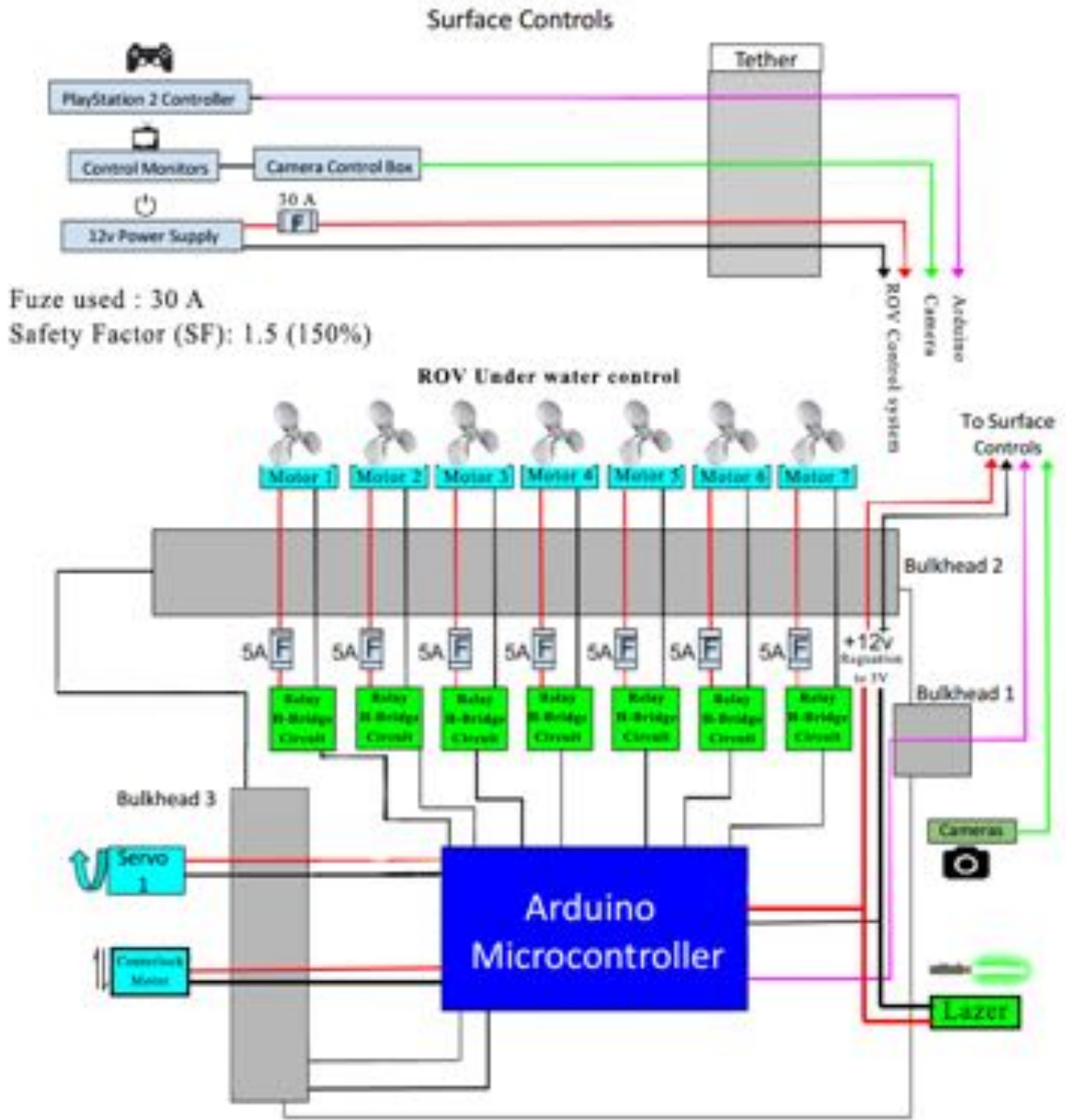

Flowchart

Team work Flowchart:

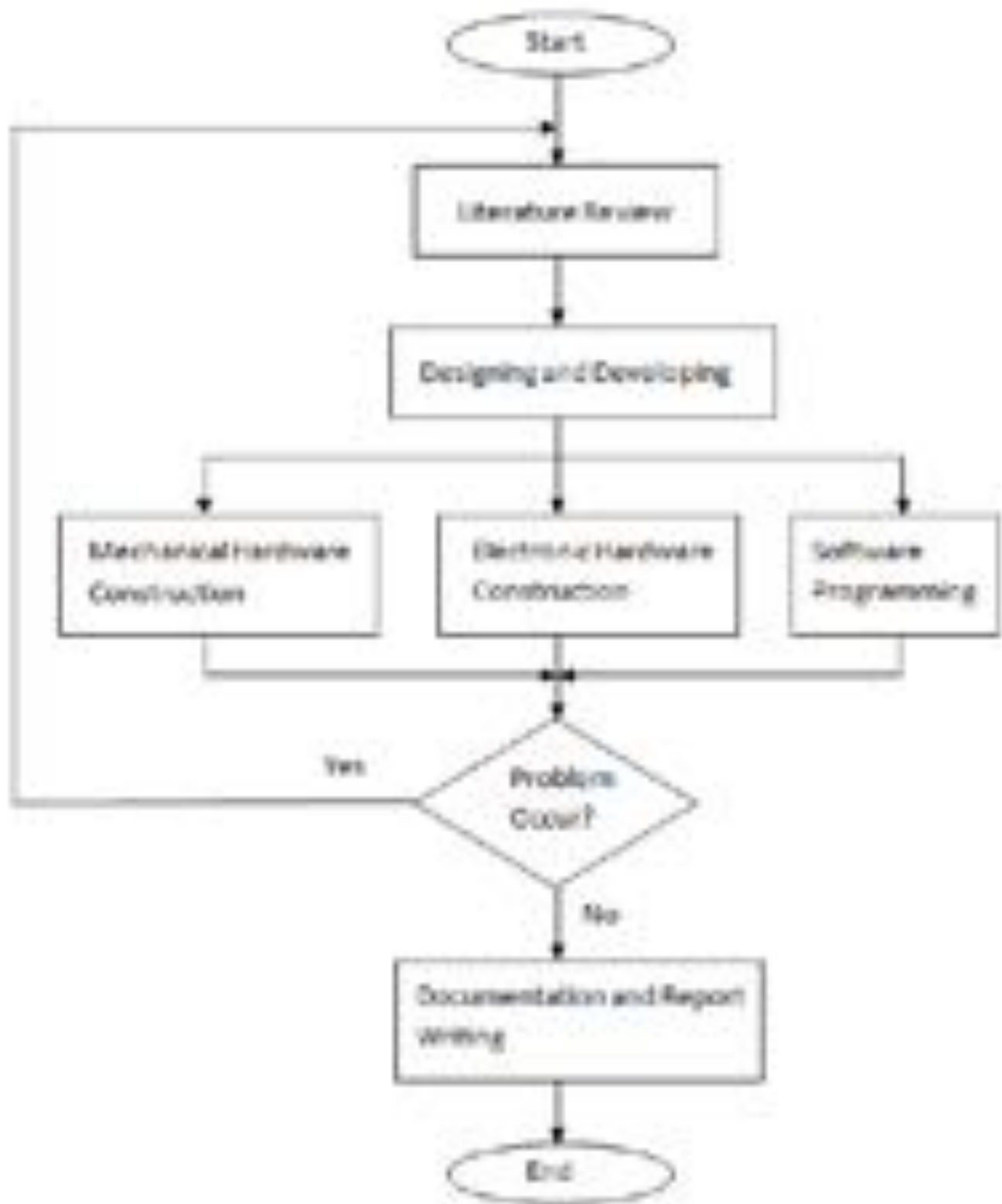

The software Flowchart

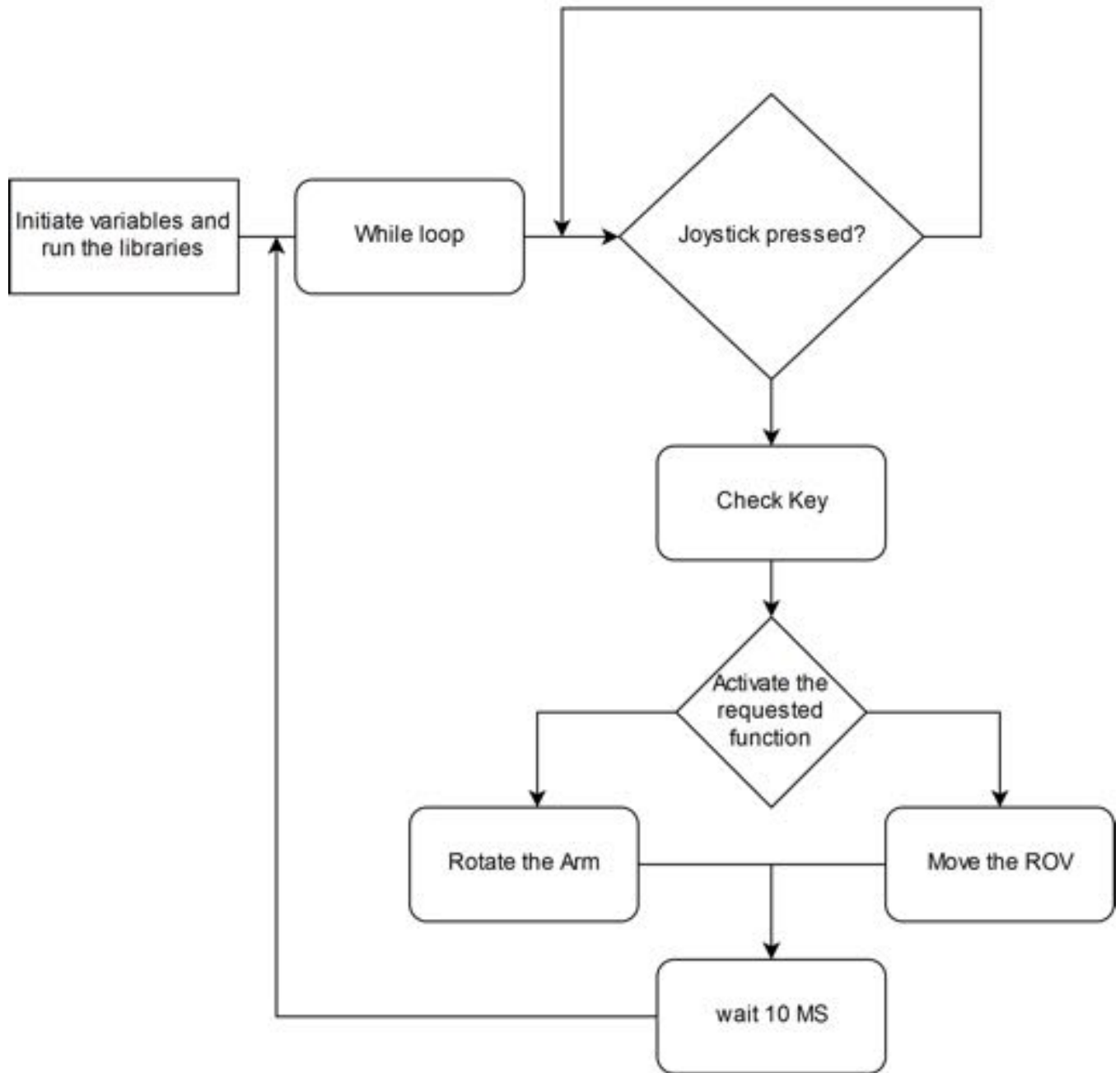

Acknowledgments

As the first team from Jordan, we are so glad to be the leaders in underwater technology and ROV in the region after Egypt.

We won't be able to make it without our supporters and sponsors.

1) Ashraf Al Refai:

A Jordanian businessman cares about tech entrepreneur and education, Ashraf Al Refai support us with plane tickets and a good part of the team accommodation.



2) Al Ahli Bank:

A Jordanian bank supported us with 2800 USD cash to develop our ROV and part of commendation



3) FabLab Jordan:

The largest fabrication lab in the region, it was our technical sponsor that let us to use 3d printers and laser cutting machines



4) Eureka Tech Academy

The first academy in Tech Education in Arab region, which supported the team with all equipment and technical support

