



The  
University  
Of  
Sheffield.



# AVALON

## TECHNICAL REPORT

### Members (Year)

Khaled El Sayed (2<sup>nd</sup> )  
Marwan Khaled (1<sup>st</sup> )  
Abhinav Kongari (2<sup>nd</sup>)  
Adham Darwish (2<sup>nd</sup> )  
Ronak Sharma (2<sup>nd</sup> )  
Alex Dada (1<sup>st</sup> )  
Ife Ajiboye (2<sup>nd</sup> )  
Marta Grzybek (2<sup>nd</sup> )  
Anjani Wirasinghe (2<sup>nd</sup> )

### Roles

CEO  
CTO  
Mechanical Engineer  
Mechanical Engineer  
Software Engineer  
Software Engineer  
Electrical Engineer  
General Engineer  
General Engineer

## Abstract

*Avalon*, present their first product, *Cuppa*, a multi-purpose Remotely Operated Vehicle (ROV) designed specifically to tackle a variety of underwater challenges in precarious conditions of the seaport requested by The Port of Long Beach. *Cuppa* is equipped with 6 thrusters which provide excellent manoeuvrability and a gripper to perform precise tasks. These and other technical features allow it to tackle challenges such as hyperloop construction, light and water show maintenance, environmental clean-up or risk mitigation. The modern technologies such as 3D printing used in manufacturing process of the *Cuppa* and the selection of light materials allowed *Avalon* to create a low weight, compact and efficient vehicle at a low cost. It was manufactured with strict accordance to the safety protocols and the client's specifications, which makes it perfectly suitable for its purposes.

*Avalon* is a first from England, nine-person underwater robotics company whose aim is to make engineering ideas happen and improve the learning experience. To achieve this, the company is divided into software/electrical, mechanical/manufacturing and non-technical teams. Employees of each of them have used their technical and management skills to design and construct the ROV from the very beginning. *Cuppa* is a result of months of teams' collaboration, planning, designing, constructing and testing phases which were completed successfully due to an excellent communication and teamwork, the main qualities of *Avalon*.

This technical report presents details about every aspect of the project and how the successful outcome was achieved. It also gives an insight into challenges faced and future improvements.



## Table of Contents

Abstract	1
Design rationale	3
Mechanical design process	3
Thrusters configuration	3
Chassis	3
Control Boxes	4
Vision system	4
Manipulators	5
Agar suction cup	5
Valve turning mechanism	5
Gripper	5
Tether	6
Electrical system	7
Power system	7
Printed circuit boards	7
Programming	8
ROV Control Interface	8
ROV Onboard Controls	9
Image Analysis	9
Management	9
Schedule	9
Budget	10
Workflow	12
Conclusion	12
Non-technical Challenger	12
Technical Challenges	13
Future Improvements	13
Reflection	13
Outreach	13
Acknowledgments	15
SID	16

## Design Rationale

### Mechanical Design Process

The main aims of the design process were to have high manoeuvrability and ease of operation and maintenance. When tackling different design problems, the company brainstorms different ideas. The best idea is then chosen and implemented on CAD. Through an iterative process, weaknesses in the design are identified and fed back into the brainstorming process to come up with the improvements. Once the engineers are happy with the outcome of the design process, a prototype is made and tested. This process allows for cost effective rapid designing.

### Thrusters Configuration

The ROV, shown in Figure 1, has got 6 Bluerobotics T100 thruster propelling it through the water, 4 of which are responsible for the horizontal motion arranged in a 45 degree vectored configuration, and the other 2 are responsible for the ROV's vertical motion. This configuration enables the ROV to have 5 DOF, 3 of which are translational; heave, surge and sway as well as 2 transitional degrees; yaw and pitch. This configuration will aid the pilot to solve the mission easily as it provides him with full control in all the main directions needed to complete the mission. Moreover these thrusters offer excellent performance for our purposes compared to their cheap price compared to other thruster out their.

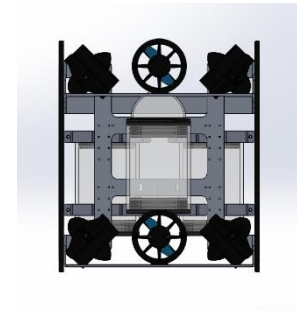

Figure 1 ROV Top view

### Chassis

Our simple and elegant ROV chassis is designed out of five main parts; two side plates, two top connecting brackets, a middle bracket and a lower bracket. Cuppa is 410mm x 356mm x 322mm which makes the ROV fit inside the 58cm diameter and since the ROV's weight is under 10 Kg, we are expected to receive the size and weight bonuses.

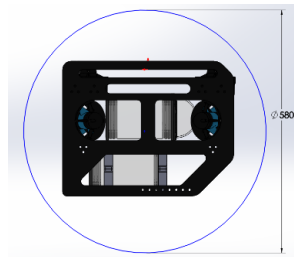

Figure 4 ROV Side View Dimensions

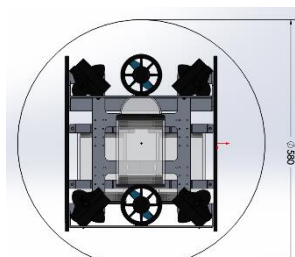

Figure 3 ROV Top View



Figure 2 Quick release skewer

The side plates of the chassis, are made out of 8 mm CNC routed Acetal, which was chosen for its low density, high strength as well as ease of machining. The middle slots were placed appropriately for effective water flow in and out of the thrusters. The Bottom Slot was placed for decreasing the drag that might have been caused by this part when moving the ROV laterally but no instead the water hits the control box cylinders which provide less drag as well as for weight reduction. Moreover, slots were made on the top wide enough to allow for easy holding and transporting of the ROV.

The four side plate connectors were manufactured from laser cut then CNC folded 4 mm thick aluminium. We need a metal that could be folded, does not corrode easily when used under water and also light weight, that's why aluminium was chosen. The top connectors are used to mount the vertical thrusters, the front top connector is secured to side plates with bolts and nuts while the rear top bracket is fixed to the side plate with quick release skewers which enable us to have access to the end cap of the main control box giving us quick access to the electronics inside for maintenance and upgrades. The middle connector is the main connector as the four horizontal thrusters are mounted on it as well as our three control boxes are mounted to it as well.

The Lower connector is used as mounting base for our manipulators.

## Control Boxes

Our ROV chassis contains three control boxes containing our electronics. The decision of having three separate control boxes originated from the idea of keeping access to all of the electronics as simple and easy as possible, especially that there were a lot of them.

Our control boxes are made out 6mm clear cast acrylic due to its high strength, lightweight and being nearly neutrally buoyant. Acrylic was specifically chosen over aluminium as it is transparent thus making the visual inspection easier and allowing us to easily detect any water leakage inside.

Since the cylindrical shape have a low drag coefficient this ensures efficient operation of the ROV. Moreover, cylindrical shapes can withstand high pressure because forces are distributed evenly across the surface and the cylindrical shape self supports itself. The cylinder sizes were kept to a minimum because the net forces acting on a submerged control box is equal to the pressure differential multiplied by surface area.

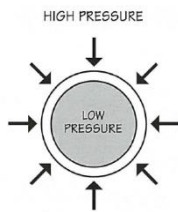

Sealing our control boxes was one of the biggest challenges faced during the design process and we decided to use end caps with radial O-rings to create a tight seal between the cylinder and the end cap, also cable glands are being used to pass cables through the end cap from to get power and signal in and out of the control boxes.

Figure 5 Pressure Distribution

Our first end cap prototype was resin 3D printed which was tested under water but it leaked because the bottom of the O-ring groove was not a smooth circle. It was approximated with short lines which caused the water to seep from behind the O-ring. Then it was decided to turn the endcaps out of HDPE, but the surface finish of the O-ring groove was not smooth thus causing leaks. 4 inch O-ring flanges were bought from BlueRobotics to meet the time constraints and was used to make the custom end caps and laser cut them out of acrylic.



Figure 6 Resin 3D Printed End Cap. Captured by Marwan.



Figure 7 Cable glands going into control boxes. Captured by Marwan.

Our mechanical team implemented a nice way to test our control boxes for leaks. We used a hand vacuum pump to pump air out of the cylinders till the pressure difference between the inside of the control box and the atmosphere was equivalent to 7m of water pressure and this increase in pressure on the vacuum pump' was analysed using a pressure gauge. This method also came in handy when testing different types of cable glands. After the vacuum test, the control box was submerged in the pool for 40 mins.

## Vision System

Cuppa has got onboard two wide angled analogue cameras, one of which is inside the dome which is mounted on a manual tilting mechanism allowing adjustments to suit the pilot needs, providing view on the Manipulators and the other is facing downwards to capture pictures for the risk mitigation task.

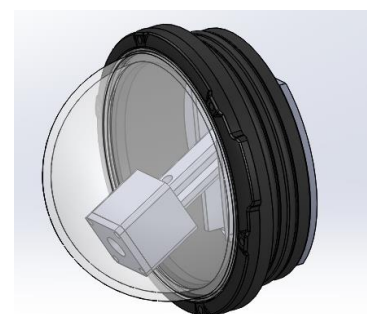

Figure 8 Manual camera angle adjusting mechanism. Captured by Marwan.

## Manipulators

### Agar Suction Cup

The mechanical team developed an agar collection mechanism, which works by lowering the this cup into the agar, when the cup is being lowered the water will be displaced by agar and will escape through the venting holes at the top till all the water is displaced, when agar starts coming out of the venting holes the pilot can then suction cup from the agar cup and the agar should come out in the cup because all the water has been displaced by agar.

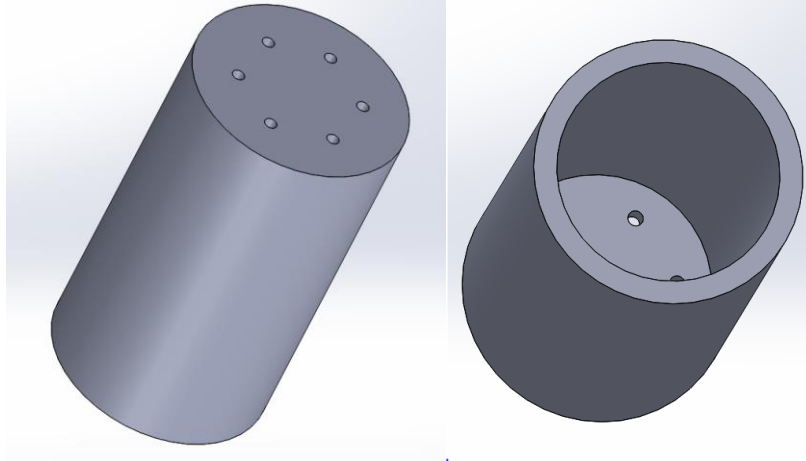

Figure 9 Agar Suction Cup

### Valve Spinning Mechanism

A funnel fitted with foam on the inside is used to spin the valve and this valve is mounted on a stepper motor mount. The funnel allows the pilot to easily grab the valve as it increases the attack angle.

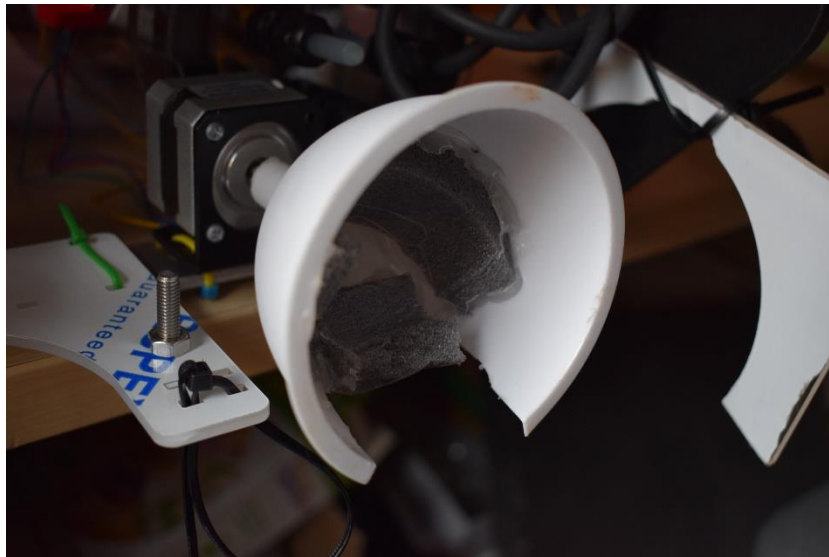

Figure 10 Valve turning mechanism Captured by Khaled.

### Gripper

The mechanical team is working on fitting a gripper to Cuppa to enable to solve most of the missions. They will be utilising MakeBlock Robot Gripper.



Figure 11 MakerBlock Robot Gripper

## Tether

Cuppa's tether consist of two power wires along with an ethernet cable. The power wires are 11 AWG each since our tether length is 16m we are getting a voltage drop of about 3.9V when consuming 30A and under normal operating conditions our ROV consume about 12A giving us a lower voltage drop of only about 1.5V which according to the electrical calculations should not affect the electrical system. The ethernet cable is made up of wire 4 of which are used for the UDP communication between the ROV and the station, and the other four wires are used to send the camera signals to the DVR, two wires for each camera.



Figure 12 Tether. Captured by Marwan.

## Electrical System

### Power system

Most of the electronic components in the ROV work on 12V or less and the ROV is supplied with 48V. To convert 48V to 12V we used 7 Meanwell MHB150-48S12 DC DC converters capable of converting 48V to 12V with a current range of up to 12.5A. Each thruster is getting power from a separate convertor, and the controllers, cameras and manipulators are getting power from the remaining converter.

The convertors are soldered on PCB that we designed and fabricated. The convertors are then stacked in groups of 3 using spacers that are used as well to supply them with 48V.

Each stack along with 3 ESCs are put in one of the low control boxes. The ESCs are connected to the converter boards via XT60 connectors. This design makes the system modular, if one converter fails only one thruster will be down without affecting other thrusters operation, this makes the system robust and makes swapping a faulty converter easy. The thrusters are connected to the ESCs via MT60 connectors, using the MT60 and XT60 connectors makes the system installation easy as well as making future upgrades or maintenance and debugging.



Figure 13 DC-DC Converters stack. Captured by Marwan.

### Printed Circuit Boards

Cuppa's electric system consists of 2 main PCBs. The first PCB is an Arduino shield for controller on, it contains a voltage regulator to change the 12V to 5V to power the Arduino and the ethernet, it also contain various JST connectors to make connections to various components out of the board such as the I2C bus, manipulators signals and LED power.

The second PCB is also an Arduino Shield for the second controller, it contains a voltage regulator to power the controller 2 as well as the HC-05 Bluetooth module, it also contains JST connectors to provide PWM signal for the ESCs and a connector for the I2C bus.

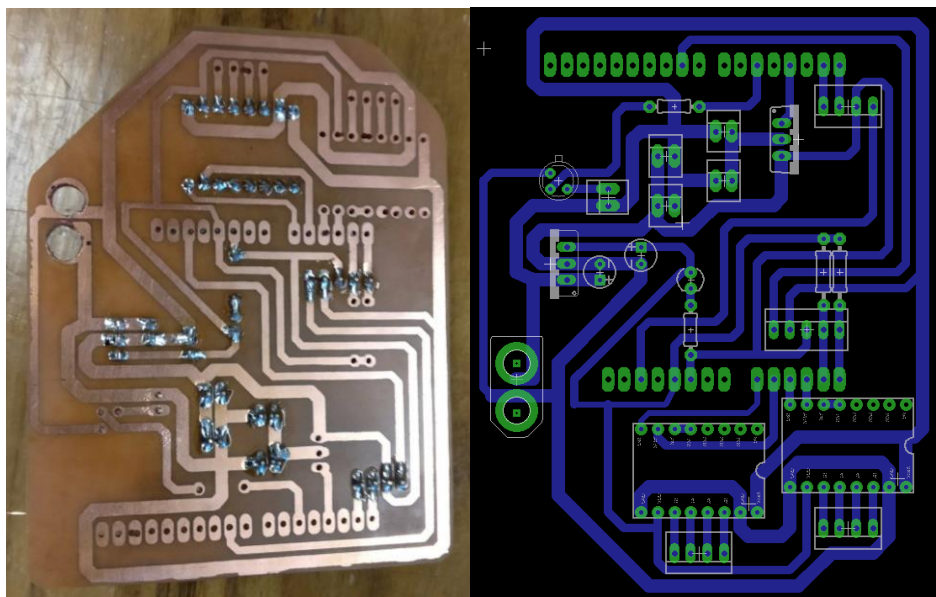

Figure 14 First PCB. Captured by Marwan.

## Programming



Avalon’s Cuppa software followed a basic distributed control system structure. It consisted of three sets of programmes; Control Interface, Onboard Control and Image Analysis. The Control Interface runs on a laptop to monitor and control the movement of the ROV. The Onboard Control receives information from the Interface and interprets for the different thrusters and manipulators. The Image Analysis software is used to layover a grid on top of the camera feed in order to help in mapping different structures.

### ROV Control Interface

This section was written in Python language using Anaconda as Integrated Development Environment (IDE) being a user-friendly interface. Modules ‘Pygame’ and ‘Python QT’ were used in a combination to provide more features to the pilot for the easiness of control over the ROV. Although Pygame could be used to create GUIs, the company has opted for QT because of its ease of use and because it offers more functionality. This program generates a display screen which presents the co-pilot with the values being sent to the ROV to easily identify any discrepancy in the movement of the ROV during a task. This programme runs on a laptop and communicates with a Thrustmaster joystick connected to the laptop’s USB port. It receives the data once the joystick is put into action and then interprets the data using a conditional algorithm to determine the speed and the direction of each of the seven thrusters on the ROV. The combination of these parameters is then used to determine the different movements of the ROV like rolling, yawing and pitching. A damping factor was used to adjust the data sent to the ROV to prevent supplying very high power to the thrusters as this could lead to inefficiency in controlling the ROV. The input from the joystick was restricted and then mapped according to the thruster power graph, to prevent any heavy calculations at later stage thus ensuring much faster processing of data on the ROV. A variable dead zone was used in the algorithm to prevent the ROV from performing any unintentional minute movements which might arise due to human error. Both the data from the joystick and the processed data being sent to the ROV was displayed to the co-pilot on an alternate screen to access if needed. To obtain more control from the joystick, multiple buttons and axes can be used in combination to provide different functions.

The processed data is sent to the Arduino in the Motor Communication Algorithm via UDP communication protocol. This data includes values for the different thrusters and actuators. UDP protocol was chosen over TCP due to high speed and efficiency. The latency and the information lost during UDP were compensated by analysing and processing the information at a faster rate on the laptop. This data was sent in array structure to make its interpretation easier at the next stage.

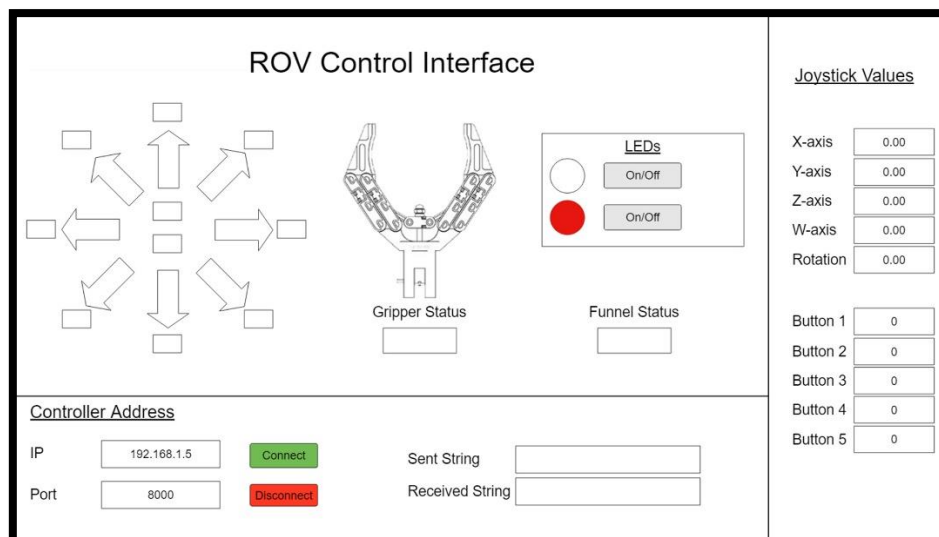

Figure 15 Computer Interface

### ROV Onboard Controls

There are two Arduino controllers on board the ROV, each running its own code and communicating over I2C. Controller 1 uses an ethernet shield to receive data from the laptop using UDP protocol. The controller then interprets the data and sends the thruster values to Controller 2. Controller 1 also controls the different manipulators on board of the ROV. Controller 2 translates the values received from Controller 1 into PWM signals that are then sent to the different thrusters through the ESCs. Controller 2 also controls a Bluetooth module.

### Image Analysis

The software uses Open CV to add a grid to the camera feed, which is then used to measure distances with reference to the pool lines.

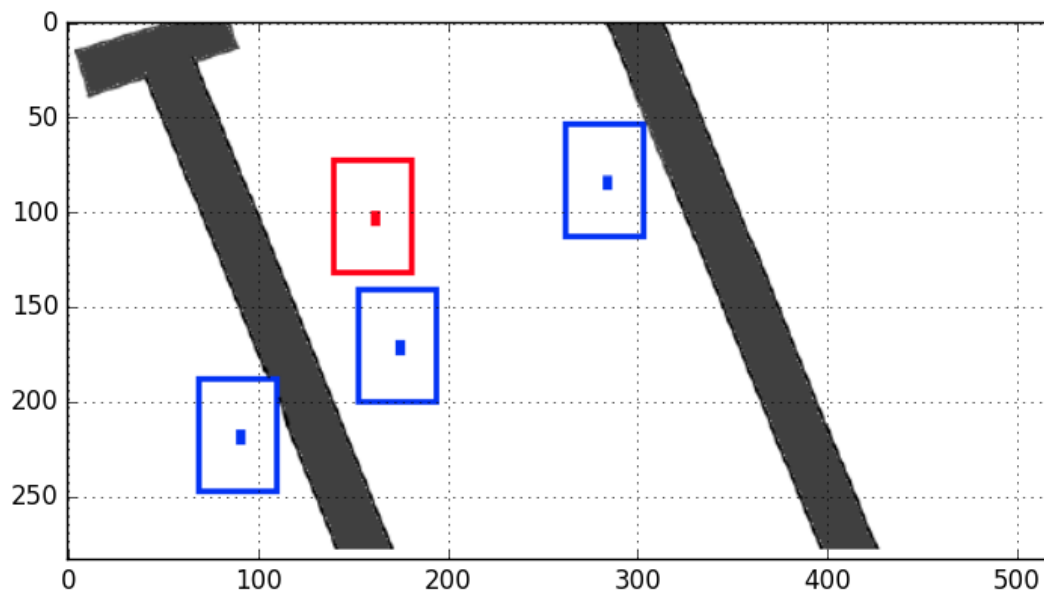

Figure 16 Image Analysis Software simulation

### Management

#### Schedule

At the start of the project, an overall plan was put in place to organise the work effort. This plan focused on the main subsystems of the vehicle and building phases, covering things such as electrical system design and chassis design. As a new company, we did not have previous experience in building ROVs, so we relied on our experience from other similar projects. Technical reports from other companies were also used as a guideline on how long a given task may be expected to take. The plan was made into a Gantt chart, which can be seen in figure, to easily keep track of main tasks and deliverables.

This plan was then divided into smaller sections and tasks to be assigned to the different team members with specific deliverables. Overall, the work has been going according to plan but as a company, we realised that it is important to be adaptable and flexible to account for any delays or unforeseen circumstances. This has been especially important because we are a new company.

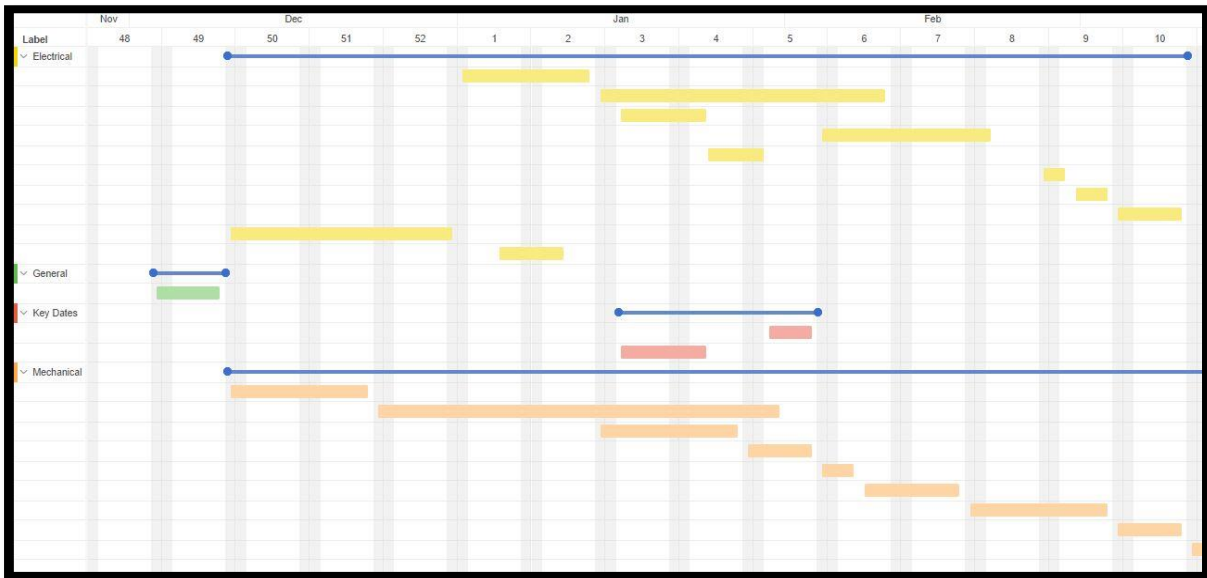

Figure 17 Project Initial Gantt Chart

## Budget

One of the initial stages of the project was budget planning. The ROV cost estimates were based mainly on the CTO's previous experience in MATE ROV competition. The budget was split into 2 parts, the costs related to the ROV itself and the other for covering remaining expenses such as travel and accommodation of the employees. Having done the ROV budget plan of components and services, the financial safety margin was taken into consideration to give the company a flexibility to cover extra costs that would potentially arise during the R&D and testing stages. The income was obtained from various sources at different times during the project duration. The initial effort was put towards covering the ROV expenses and once it has been achieved, the second budget was filled.

The finance flow was controlled and controlled on a regular basis throughout the duration of the project. Every expense was registered in the table presented below and tracked against the remaining budget.

ROV expenses					
Discipline	Item	Type	Qty.	Total £	Total \$
Electrical	Cameras (IP, parking)	Purchased	2	£45.99	\$59.79
	Internet Switch	Purchased	1	£18.00	\$23.40
	Connectors (pin, Anderson)	Purchased	11	£6.72	\$8.74
	Copper Clad	Purchased	3	£6.75	\$8.78
	ESCs	Purchased	7	£90.87	\$118.13
	DC - DC converters	Purchased	7	£415.03	\$539.54
	Ethernet cable	Purchased	1	£12.24	\$15.91
	Power cable 30m (black, red)	Purchased	2	£56.74	\$73.76
	Jumper wires	Purchased	1	£4.95	\$6.44
	Con-Molex pins	Purchased	112	£11.60	\$15.08
	RJ45	Purchased	1	£2.11	\$2.74
	Crimps	Purchased	228	£7.00	\$9.10
	Resistors (4.7k, 330, 1k, 10k)	Purchased	80	£2.76	\$3.59
	Capacitors (10uF, 22pF)	Purchased	24	£1.14	\$1.48
	LED 3mm	Purchased	10	£3.14	\$4.09
	2N2222 Transistor	Purchased	6	£11.66	\$15.16
	RFP12N10L N-Channel MOSFET	Purchased	5	£1.92	\$2.50
	7805 Voltage Regulator	Purchased	8	£2.63	\$3.42

	16MHz crystal	Purchased	6	£1.73	\$2.25
	IC Holder 28pin	Purchased	5	£2.84	\$3.70
	Heat Shrink (1.6, 3.2,4.8mm)	Purchased	9	£25.38	\$32.99
	Atmel atmega 328	Purchased	3	£8.57	\$11.14
	Strip board	Purchased	3	£8.17	\$10.62
	20mm Spacer	Purchased	24	£11.24	\$14.61
	30 amp Fuse	Purchased	5	£0.92	\$1.20
	Glossy Photo Paper	Purchased	1	£8.60	\$11.18
	Electrical components	Purchased	8	£15.38	\$19.99
	Stepper motor driver	Purchased	2	£10.08	\$13.10
	DVR	Purchased	1	£34.99	\$45.49
<b>Mechanical</b>	Vaccum Pump	Purchased	1	£17.00	\$22.10
	Rope	Purchased	1	£3.90	\$5.07
	Glands	Purchased	9	£26.62	\$34.61
	Plastic Sheet 50x50	Purchased	2	£14.00	\$18.20
	Acrylic cylinder 56ID	Purchased	1	£33.00	\$42.90
	Thrusters	Purchased	7	£722.71	\$939.52
	Screws, Washers, Nuts	Purchased	426	£13.97	\$18.16
	M5 threaded rod 1 meter	Purchased	1	£1.32	\$1.72
	150 mm Hose clamp	Purchased	2	£3.90	\$5.07
	Brackets	Purchased	1	£112.50	\$146.25
	Side Plates	Purchased	1	£132.67	\$172.47
<b>Manufacturing</b>	Copper cleaner	Purchased	1	£3.75	\$4.88
	PCB Etching Acid	Purchased	1	£15.40	\$20.02
	Acrylic Glue	Purchased	1	£15.05	\$19.57
	Loctite	Purchased	1	£4.99	\$6.49
	Marine epoxy	Purchased	3	£12.21	\$15.87
<b>Tooling</b>	Hacksaw	Purchased	1	£6.00	\$7.80
	File	Purchased	1	£2.21	\$2.87
	Pliers set	Purchased	1	£7.56	\$9.83
	G-clamp	Purchased	1	£3.74	\$4.86
	Wrench Set	Purchased	1	£7.14	\$9.28
	Spanner (8,10,19mm)	Purchased	4	£8.62	\$11.21
	Screw driver Set	Purchased	1	£5.98	\$7.77
	wire stripper	Purchased	1	£3.21	\$4.17
	RJ Crimper	Purchased	1	£3.25	\$4.23
	<b>ROV total cost</b>			<u>£2,038.76</u>	<u>\$2,650.39</u>
<b>Other expenses</b>					
<b>Other</b>	Travel expenses	Purchased	6	£3,500.00	\$4,550.00
	Accommodation	Purchased	6	£1,100.00	\$1,430.00
	Meals	Purchased	6	£400.00	\$520.00
	Entry fee	Purchased	1	£208.35	\$250.00
	<b>Other total</b>			<u>£5,208.35</u>	<u>\$6,750.00</u>
	<b>Overall</b>			<b>£7,247.11</b>	<b>\$9,400.39</b>

<b>Income</b>			
Type	Description	Amount (£)	Amount (\$)
Donation	The University of Sheffield - Faculty of Engineering	£2,450	\$3,185
Donation	The University of Sheffield - Alumni Fund	£2,100	\$2,730
Donation	University of Sheffield Enterprise	£208	\$271
Donation	The University of Sheffield - engineering departments	£3,050	\$3,965
Donation	Thales Group	£1,500	\$1,950

<b>Total income</b>	<b>£9,308</b>	<b>\$12,101</b>
---------------------	---------------	-----------------

<b>Budget</b>		
<b>Finance flow</b>	<b>Amount (£)</b>	<b>Amount (\$)</b>
ROV cost	£2,039	\$2,650
Other cost	£7,247	\$9,400
Total expenses	£9,286	\$12,051
Income	£9,308	\$12,101
<b>Balance</b>	<b>£22</b>	<b>\$50</b>

### **Workflow**

Coming up with a system to organise tasks, deliverables and files has been very vital to the company's success. This system took the form of several apps that we used to manage tasks and files as well as regular meetings to discuss progress.

For tasks, the company relied mainly on Trello. After trying several methods, Trello was found to be the most effective to use, as it enabled tasks to be assigned to individuals with set deadlines. It also collected all the information about any given task in one place, which helped us stay organised.

To manage and store files, the company utilised Google Drive because of its ease of use. A folder structure was set from the beginning to separate and classify individual sections of the project, such as budgeting and mechanical designs. Google Drive was also used to create shared documents which enabled collaborative writing remotely and easily.

To ensure that all the company members are up to date and are working according to the schedule, weekly meetings were set to discuss progress and tackle problems. These meetings included all members at the beginning of the work and was then divided into sub-teams, such as mechanical and electrical, to increase efficiency. Different sub-teams often met when needed to discuss overlapping systems.

Finally for communication the company used a Facebook group to easily communicate small updates.

### **Conclusion**

#### **Non-technical Challenges**

As a new company, we had a number of challenges especially when it came to funding and finding an appropriate space to build and test the vehicle. These problems often conflicted with the technical aspects of the project and so we realised, very early on the importance of balancing both the technical and the non-technical aspects of the project.

To obtain funding we focused on the University of Sheffield, where we are based, as well as external sponsors. Because we did not have previous products to showcase, we relied on our skill sets and the fact that we are the first team from England to enter the competition as unique selling points.

Finding places to test the vehicle was another major challenge that we had and we were able to overcome that by approaching local community centres and gyms that offered us their pools.

## **Technical Challenges**

Most of the technical problems that we had originated from being new. The main issues that we faced were not having enough technical support and not having a dedicated manufacturing facility to rapidly build and test parts.

For technical support we got in contact with the National Oceanography Centre (NOC), and we met with their engineers to discuss our designs and get inspiration from their vehicles. This was very useful for us as a starting point. We also communicated with other companies that have participated in the competition over the years to learn more from them.

For manufacturing, we relied on the University of Sheffield labs when possible, especially for laser cutting and 3D printing. However, for larger parts that as the chassis we opted for outsourcing the parts in the interest of time.

## **Future Improvements**

Participating in the competition for the first time provided us with various opportunities to reflect upon our current strategy and make improvements to it in the future. Being a multidisciplinary team had its advantages but some disadvantages as well. One of problems discovered was the lack of effective communication which was due to insufficient involvement of the members in different tasks. Members of sub teams were unaware of the work in other sub teams thus leading to confusion and delays. In the near future it was decided it is necessary for all the member to have an overview of the work of the different sub teams by sharing with them the work being performed in teams during a compulsory weekly meeting for all members to attend.

During the course of this project we had faced some other issues like finding a suitable pool and manufacturing components. These problems demotivated some members as they felt that the project could not be accomplished thus degrading their performance. So it is decided to keep the members constantly motivated by appreciating their small contributions to this project. Also more get togethers would be organised to improve the compatibility of the members of the team

## **Reflection**

Working on this project has been an extremely rewarding experience for us as a team. It has helped us develop a wide range of skills including time management and resources allocations. It was also very useful for us to apply the theoretical knowledge that we learn at university in a real life project. Furthermore, we have developed an understanding of the importance of the non-technical aspects of any engineering project, such planning and budgeting.

We have learned a lot from participating this year, but we have also identified a lot of areas of improvement and we are hoping to act on these areas throughout the rest of the project and in future years.

## **Outreach**

Outreach is an aspect that holds an important place within the company. This company believes in gaining knowledge and then passing that knowledge on to the community/public. It is an important duty to expand people's understanding of STEM subjects and show the wonders of it. To achieve the mission of passing knowledge and inspiration, the company has created a Facebook page and participated in an event. The company has been scheduled to participate in future outreach events and open days. Our target audience is the public with various ages and backgrounds.

A Facebook page has been created to reach audience on an international scale. Posts are posted to show the company's journey and progress with the ROV. The page is a very efficient way of reaching an audience as using this method is free and easy to do. This is also a great way of growing the company

over time when followers who follow the page will keep seeing our posts and share, making more people aware of the ongoing STEM work.

STEM for Girls is a community event which the company attended to showcase MATE ROV. This event was specifically for girls who are currently in high school and are at the age of deciding what they want to do in the future. By participating in this event we managed to reach approximately 1500 young girls and expand their knowledge of engineering. We had a wonderful time speaking to the girls and many of them showed a lot of interest in engineering.

The company wants to continue the mission by participating in future outreach events and university open days.



Figure 18 Our booth in STEM for Girls outreach event. Captured by Khaled.

## **Acknowledgments**

We would hereby like to thank National Oceanography Centre (NOC) for their constant support and guidance in the initial stages of this competition.

We would also like to thank Thales and Faculty of Engineering at the University of Sheffield for sponsoring our travelling and food costs.

Also thanks to Liz Taylor for her help with recognising funding opportunities.

Thanks to Alumni Foundation for providing us with the funding to build our ROV.

Finally thanks to the following organisations:

Sheffield Robotics

Solidworks

MATE

ZEST Community Centre



# SURFACE

# WATER

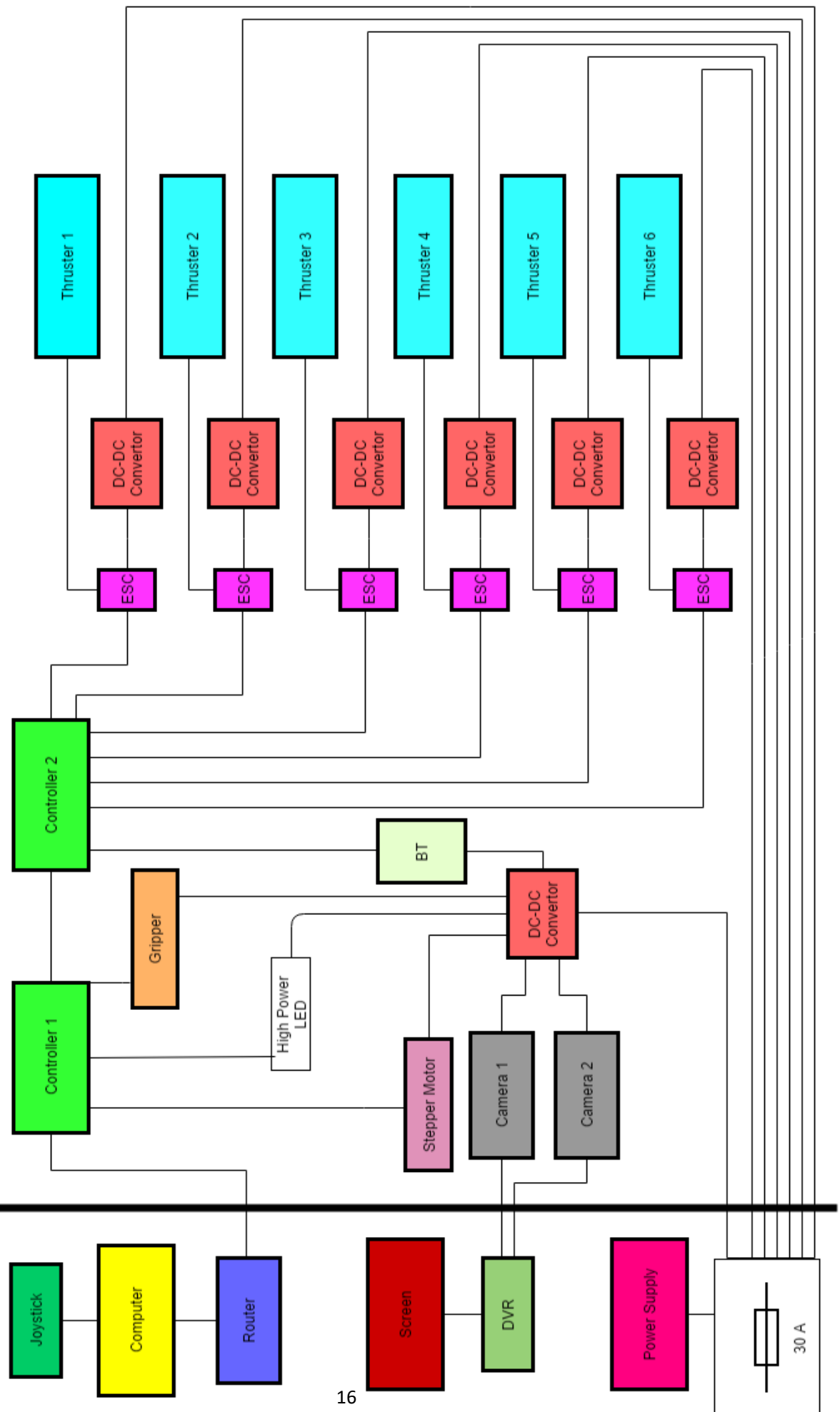

ROV Overcurrent protection

- 6 Thrusters 2.8A each, total = 16.8A
- 2 Camera 0.5A, total = 1A
- 20Watt High power LED = 0.42A
- 2 Stepper motors 0.075, total = 0.15A
- Total Amps = 18.37x 150%=27.6 A
- ROV uses a 30 A fuse